

HATCH

UTA Light Rail Strategic Plan



January 2023

Document Number: C5525.02

Future of Light Rail Study



Table of Contents

- 0 Revision History.....5
- 1 Light Rail Strategic Plan Introduction6
 - 1.1 Study Purpose7
 - 1.2 Study Public Engagement9
- 2 Recommendations13
- 3 System Expansion15
- 4 TRAX Fleet Plan.....18
 - 4.1 Purpose of the TRAX Fleet Plan18
 - 4.2 Train Length Considerations.....18
 - 4.3 Car Floor Height and Accessibility Considerations19
 - 4.4 TRAX Fleet Plan Next Steps20
- 5 Recommended Infrastructure Renewal and Improvements22
 - 5.1 Trunk Line Speed Improvements.....22
 - 5.2 Union Turnback Track and Green Line West to South Connection23
 - 5.3 400 West (Pioneer Park) Non-Revenue Connector24
 - 5.4 TRAX Traction Power System Improvements.....25
- 6 Transit Signal Priority Improvements29
- 7 Service Improvements34
 - 7.1 Improving TRAX Span of Service34
 - 7.2 Airport Line Extended Hours Travel Demand Analysis.....38
- 8 Potential Strategic Plan Improvements Funding Sources and Implementation Plan.....42
 - 8.1 Strategic Plan Capital Cost Estimate42
 - 8.2 Regional Transportation Plan Updating.....43
 - 8.3 Potential Funding Sources.....44
 - 8.4 Next Steps.....45

9 Strategic Plan Scenarios Development 46

Light Rail Strategic Plan Appendices..... 55

10 Appendix A – Strategic Plan Ridership and Accessibility Analysis..... 55

 10.1 Forecasting Tool 55

 10.2 Assumptions 56

 10.3 Travel Demand Model QA/QC Process and Methodology 56

 10.4 Travel Demand Model Metrics..... 57

 10.5 Travel Model Results 59

 10.6 Granary District and Research Park Service Population and Employment Growth..... 63

11 Appendix B – Operations Simulation Results..... 65

 11.1 Existing Light Rail Fleet 65

 11.2 Existing Civil Speed Restrictions 67

 11.3 Existing Wayside Signaling 67

 11.4 Existing Intersection Priorities/Delay Probabilities..... 67

 11.5 Existing TRAX Baseline Operating Plan..... 68

 11.6 Existing Operations Calibration 69

 11.7 Existing Baseline Simulation Results..... 70

 11.8 Strategic Plan Operations Simulation Key Assumptions 72

 11.9 Strategic Plan Operations Simulation Results 72

12 Appendix C – Operations and Maintenance Cost Estimating Methodology..... 78

 12.1 Data Sources..... 78

 12.2 Basis of Cost Estimating Methodology 78

 12.3 Development of O&M Cost Estimates 79

 12.4 Example of Methodology..... 79

 12.5 Light Rail Business Unit Overhead 81

 12.6 Light Rail O&M Cost Model Conclusions and Limitations 81

| | | |
|------|--|-----|
| 13 | Appendix D – Capital Cost Estimating Methodology..... | 82 |
| 13.1 | Methodology Scope..... | 82 |
| 13.2 | Basis of Cost Estimating Methodology | 82 |
| 13.3 | Cost Categories..... | 82 |
| 13.4 | Unit Costs..... | 83 |
| 13.5 | Contingency..... | 85 |
| 13.6 | Escalation | 86 |
| 13.7 | Development of Vehicles Unit Costs | 86 |
| 14 | Appendix E – Granary District, Ballpark Spur and 400 South Extensions Concept Design..... | 95 |
| 15 | Appendix F – 400 West (Pioneer Park) Non-Revenue Connector Concept Design | 109 |
| 16 | Appendix G – Research Park Branch Concept Design | 112 |
| 17 | Appendix H – Trunk Line Curve Speed Upgrade Concept Design..... | 116 |
| 18 | Appendix I – Union Turnback Track and Green Line West to South Connection Concept Design | 122 |
| 19 | Appendix J – Future of Light Rail Study Technical Advisory Committee | 126 |

0 Revision History

| Revision No. | Date | Description of Revision |
|--------------|---------------|-----------------------------------|
| 1 | Nov. 30, 2022 | Initial release |
| 2 | Jan. 12, 2023 | Addressed all UTA review comments |
| 3 | Jan. 31, 2023 | Final release |

1 Light Rail Strategic Plan Introduction

UTA's TRAX light rail network, which is approaching its 25-year anniversary, has become a key component of the region's transportation system and is a nationally-recognized example of cost-effective rail transit development. Building on its success in expanding from a single "starter line" in 1999, the system must continue to adapt to evolving travel patterns to retain and improve its vital function in the overall transportation network.

Over the years, through both internal processes and regional planning efforts, a range of projects have been considered to optimize the efficiency of light rail, assure sustainability, and expand to new areas. All these elements should receive holistic examination to ensure a coordinated Light Rail Strategic Plan consistent with regional transportation planning and UTA requirements for delivering reliable, attractive, high-quality service. The UTA initiated the Future of Light Rail (FOLR) Study in March of 2020 to provide a comprehensive analysis of light rail service to provide guidance on which improvements UTA should pursue in both the near and long term.

UTA procured the services of Hatch as the lead consultant for the FOLR Study with support provided by HDR, Avenue, and Fehr and Peers. Phase 1 of the Study looked at existing conditions across the TRAX system, provided preliminary recommendations, and considered what elements of the system should be further examined in Phase 2 scenarios. Service expansion scenarios were generally limited to projects adopted and shown as funded in the Metropolitan Planning Organization (MPO) 2019 Regional Transportation Plans (RTPs) that did not have a current study underway. During Phase 2, four semi-final scenarios were analyzed. Based on the results of these scenarios, as well as stakeholder input, a final scenario was developed containing the recommended elements of the strategic plan.

UTA organized multiple stakeholder workshops and presentations, including participants from across multiple UTA Departments and Business Units, Wasatch Front Regional Council (WFRC) and Mountainland Association of Governments (MAG) staff, and planning and engineering staff from municipalities throughout the TRAX network. A UTA Future of Light Rail Study webpage¹ was created, which provides information regarding the study. UTA launched an online public survey regarding priorities for the TRAX system in Phase 1 and solicited public input on the relative importance of elements of the draft strategic plan through pop-up events at several high ridership TRAX stations and through an online survey. The Future of Light Rail Study includes a comprehensive look at the UTA light rail network with a focus on future fleet needs and opportunities for growth in both service delivery and ridership. The network under study includes the existing Blue, Red and Green light rail lines as well as the S-Line streetcar. Phase 1 of the Study, which started in March 2020, looked at major investments, such as a new line serving the Granary District and development-rich opportunities around the former Denver & Rio Grande Railroad Station, as well as smaller scale service and operational improvements that would improve travel times and make the service more competitive with other modes.

The FOLR Study was initiated just before the start of the COVID-19 pandemic and its pronounced impact on travel of all modes. Phase 1 of the Study concluded in 2021 with UTA reporting about a 60% drop in light rail ridership (and about a 45% drop in S-Line ridership) for 2020 versus the previous year. While this decline in ridership was significant, the percentage drop was less than many of UTA's peer properties and offers hope for a continued strong rebound as the pandemic ends.

The TRAX system comprises three lines – Red Line, Blue Line and Green Line – which serve much of Salt Lake County with stations located in the state capital, Salt Lake City, as well as South Salt Lake, West Valley City, Murray, Midvale, Sandy, Draper, West Jordan, and South Jordan. The Blue Line provides service between Salt Lake Central and Draper Town Center. The Red Line provides service between University Medical Center and Daybreak Parkway. The Green Line provides service between the Salt Lake City International Airport and West Valley Central. The S-Line Streetcar connects

¹ <https://www.rideuta.com/folr>

with the light rail network at the Central Pointe Station and provides service east to Fairmont Station at 1000 East in Sugar House; the S-Line uses dedicated vehicles in a stand-alone service.

1.1 Study Purpose

The FOLR Study evaluated a range of short- and long-term improvements related to fleet modifications, headways and span of service, alignments of track extensions, planned and potential station locations with consideration to projects identified in regional transportation plans and other potential enhancements. The impact of each alternative to the system at large, including associated costs, was examined. The FOLR Study considered existing conditions, operational changes in terms of travel time, capacity and reliability, and costs of various improvements.

Concurrent with the Future of Light Rail Phase 1 work, separate studies² were performed that considered transit improvements on certain corridors with the potential for light rail service. At the conclusion of Phase 1, those other studies were still in progress. Therefore, Phase 1 evaluated likely results from three studies to aid in decision making regarding the impacts of all related work on the light rail system. Those key decision points included:

- + A focus in FOLR Phase 2 on one alignment alternative through the Granary district based on findings from the UTA's Downtown Salt Lake City Rail Extensions and Connections Feasibility Study³
- + Identification of one light rail alternative serving University of Utah Research Park, based on the University's *Research Park Strategic Vision Plan* and specifically its High Capacity Transit elements

Figure 1 shows the overall FOLR Study process, including the relationship between the two phases of the Study. Phase 1 included extensive outreach to TRAX stakeholders and relevant regional agencies to identify a long list of potential light rail improvements, while also benchmarking existing system performance, capacity, and operating efficiency. In Phase 2, the Study team and UTA developed a range of scenarios to accomplish project goals and objectives. Scenarios were identified, evaluated and refined that include logical compilations of projects. Scenarios include both short- and long-term improvements including enhancements to the existing system, such as span and frequency improvements, route re-alignments, and partial fleet replacements. Phase 2 also distilled potential expansion concepts including extensions and infill stations and their associated fleet and facility needs and include their associated planning level costs.

² These separate studies include the UTA/UDOT Point of the Mountain Transit Corridor Study ([Point of the Mountain Transit Study \(rideuta.com\)](#)) and the Local Link Study that evaluated a streetcar between Salt Lake City and Millcreek ([HOME | Locallink Study](#)).

³ [DowntownSLCRailExtensionsandConnectionsFeasibilityStudy.ashx \(rideuta.com\)](#)

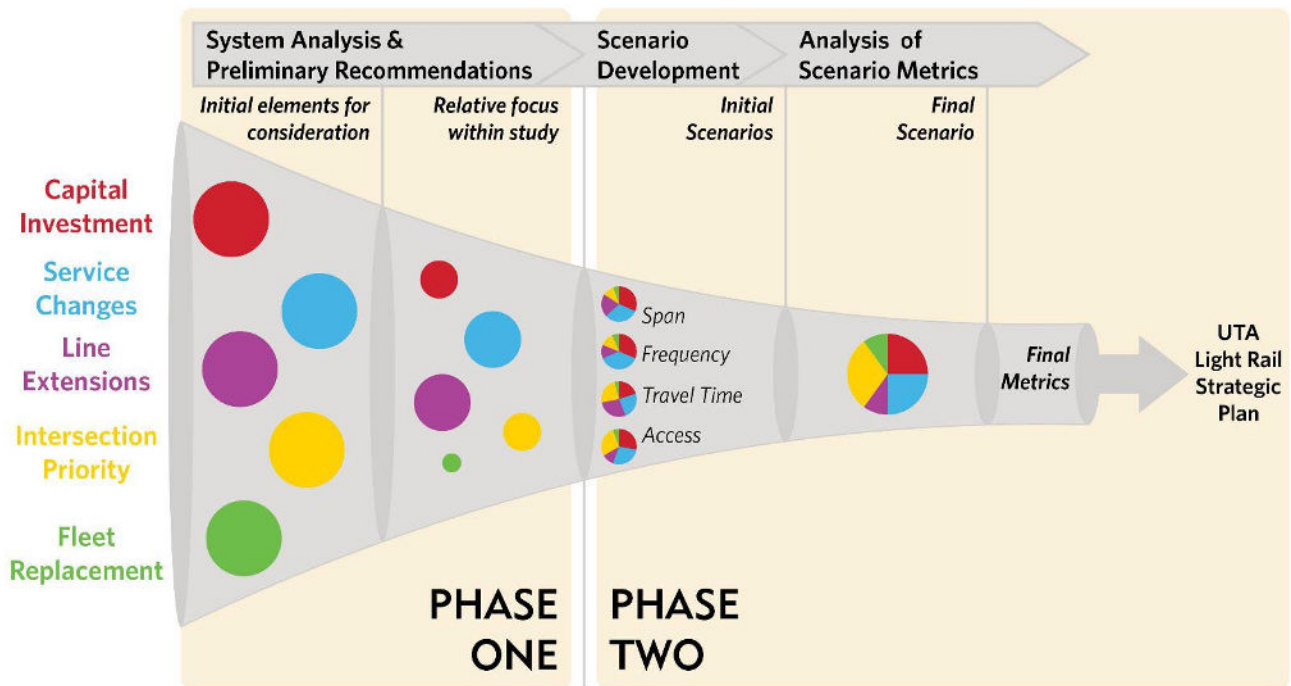

Figure 1 – FOLR Study Process

Working with the Study Technical Advisory Committee (TAC) and other stakeholders, the Study team and UTA developed a range of investment package scenarios in Phase 2 to accomplish project goals and objectives. The four investment package scenarios, which were eventually refined to form the recommended Light Rail Strategic Plan, were designed to:

- + Represent a range of investment levels
- + Include complementary – not competing – improvements
- + To the greatest extent possible, allow the benefits of individual improvements to be estimated

The initial (Phase 1) list of potential FOLR network improvements included light rail and streetcar projects shown as funded in the adopted WFRC and MAG 2019-2050 Regional Transportation Plans (RTPs)⁴ that did not have another study underway as well as other more focused improvements identified by the FOLR Study team. These served as the starting point for potential Phase 1 improvements discussed with stakeholders and the Study TAC.

In summary, Phase 2 of the FOLR Study which forms the basis of the Light Rail Strategic Plan, includes:

- + A phased approach to implementing realistic incremental enhancements that will meet immediate needs and improve operational efficiencies
- + Capital improvements that increase capacity to accommodate future growth
- + A final version of the light rail fleet plan
- + A proposed draft light rail system plan to be considered for the 2023-2050 RTP

⁴ [2019-2050 Regional Transportation Plan \(wfr.org\)](#) and [RTP Map | MAG \(mountainland.org\)](#)

1.2 Study Public Engagement

Public engagement efforts consisted of both stakeholder and general public/TRAX rider engagement efforts.

To provide a general overview of the FOLR Study, along with periodic updates, UTA maintained a Study website at <https://www.rideuta.com/folr> for the duration of the Study, which included a Study fact sheet, meeting presentations, the Phase 1 report, and information about how to get involved when applicable.

During Phase 1 in February and March 2021, UTA conducted a public survey to collect public feedback about priorities for future light rail system improvements⁵. The survey asked participants about both non-service and service factors that were most important. This information helped guide FOLR Study direction into Phase 2.

Phase 2 public engagement focused on potential improvement scenarios. Public engagement included a “pop-up” presentation and engagement at six TRAX stations, as well as an on-line survey soliciting opinions on light rail/streetcar improvements. The online survey was advertised through a targeted e-mail list that UTA maintains for customers and other members of the public who are interested in TRAX light rail.

Throughout the project, stakeholder engagement was implemented through meetings of a Technical Advisory Committee, including in-person workshops to review and get input on improvement priorities.

1.2.1 2022 Station “Pop-Ups”

UTA and the Study team selected six TRAX station locations to engage with a variety of light rail users. Court House Station captured downtown riders (including those arriving from outlying locations) while North Temple Bridge and Murray Central pop-ups largely engaged UTA customers transferring between FrontRunner and TRAX as well as local riders of the Green Line in the Rose Park neighborhood. Central Pointe captured customers from an inner mixed use neighborhood⁶ while the other stations are largely used by customers traveling from outlying cities to downtown Salt Lake City. The six station pop-ups were held on September 7 and 8, 2022 and were staffed by both UTA and members of the consultant team. The focus of the engagement was a single comprehensive board shown in Figure 2. Members of the public were asked to indicate their preference for which FOLR improvements should advance first and which improvements were less important. The board included a scaled map, shown in

Figure 3, that shows the location of each improvement, whether a site-specific improvement or a new corridor.

⁵ [Future of Light Rail Study TAC and Stakeholders Meeting \(rideuta.com\)](#)

⁶ An “inner mixed used neighborhood” refers to a community that has a mix of residential and business uses such that there is a relatively even split of ridership arriving and departing during both peak periods .



WHAT SHOULD WE BUILD FIRST?

Future of Light Rail

WHAT'S GOING ON?

UTA's TRAX network is a key component of our transportation system. The system needs updating to adapt to growth and evolving travel patterns in order to continue serving our population. The map below identifies potential improvements to the TRAX network that could be made in the future. Use the area on the right to rank these improvements in the order that is most important to you.

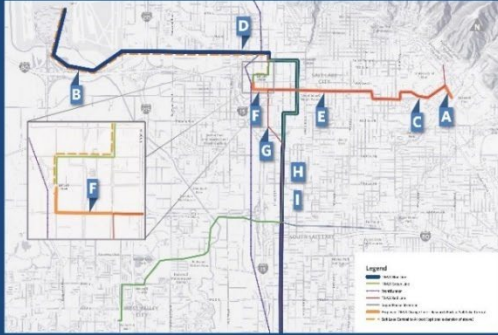

POTENTIAL BENEFITS INCLUDE:



LEARN MORE AT:
www.rideuta.com/foir

UTAH TRANSIT AUTHORITY 801-953-5882 (TDD/VOICEMAIL) @rideuta #rideuta

Rate how much you agree or disagree with the following:

| | | | | |
|-----------------------|---------------------------|-----------------|------------------------|--------------------------------|
| | | | | |
| STRONGLY AGREE | AGREE | NEUTRAL | DISAGREE | STRONGLY DISAGREE |
| "Yes! I want it now" | "It would be nice to see" | "Meh, whatever" | "Nah, I don't want it" | "No, I never want to see this" |

| | | | | | |
|----------|--|--|--|--|--|
| A | Extend TRAX to University of Utah's Research Park, on the new Orange Line | | | | |
| B | Offer all night service on the new Orange Line from downtown to the Salt Lake International Airport | | | | |
| C | Offer all night service on the new Orange Line from downtown to the University of Utah | | | | |
| D | Reroute the Blue Line to the Salt Lake International Airport and the Green Line to Salt Lake Central | | | | |
| E | Direct service from the University of Utah to Research Park | | | | |
| F | Direct service from the University of Utah to Salt Lake Central | | | | |
| G | Route the Red Line along 400 West to 900 South, to serve SLC's Granary District | | | | |
| H | Increase TRAX priority so that trains wait less at intersections | | | | |
| I | Increase speeds where possible to shorten/travel times between Central Pointe and Draper | | | | |



Figure 2 – Public Engagement Station “Pop-Up” Board Conveying Potential Strategic Plan Investments

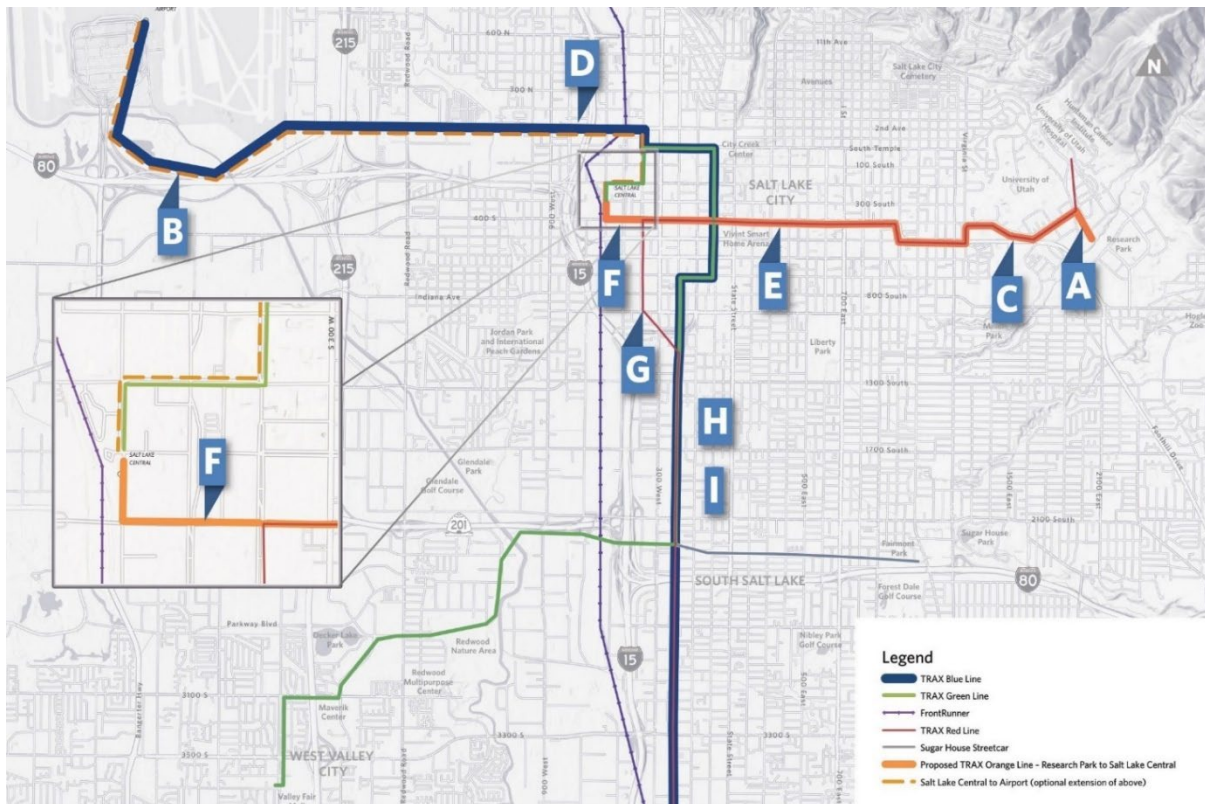

Figure 3 – Public Engagement Station “Pop-Up” Board Showing Map of Potential Strategic Plan Investments

Table 1 summarizes the results of the six station “pop-ups” individually and collectively. The two highest-ranking initiatives are the first two on the board:

- + A- Extend TRAX to University of Utah’s Research Park on the new Orange Line
- + B – Offer all night service on the new Orange Line from downtown to the Salt Lake International Airport

Other initiatives that scored high (but not as high as the first two Orange Line initiatives) were D – Reroute the Blue Line to the Salt Lake International Airport and the Green Line to Salt Lake Central and C – Offer all night service on the new Orange Line from downtown to the University of Utah.

| Table 1 – FOLR Public Outreach Results | | | | | | | |
|---|-----------------------|--------------------|--------------------------|---------------------|----------------|-----------------------------|-------|
| | Daybreak Pkwy Station | City Creek Station | N. Temple Bridge Station | Court House Station | Murray Central | Central Pointe (2100 South) | Total |
| A – Extend TRAX to University of Utah’s Research Park, on the new Orange Line | 48 | 14 | 7 | 11 | 9 | 12 | 101 |
| B – Offer all night service on the new Orange Line from downtown to the Salt Lake International Airport | 50 | 38 | 14 | 4 | 3 | 2 | 111 |
| C – Offer all night service on the new Orange Line from downtown to the University of Utah | 27 | 14 | 6 | 10 | 5 | 10 | 72 |
| D – Reroute the Blue Line to the Salt Lake International Airport and the Green Line to Salt Lake Central. | 31 | 13 | 20 | 2 | 13 | 0 | 79 |
| E – Direct service from the University of Utah to Research Park | 22 | 4 | 4 | 3 | 2 | 9 | 44 |
| F – Direct service from the University of Utah to Salt Lake Central | 20 | 15 | 5 | 13 | 2 | 2 | 57 |
| G – Route the Red Line along 400 West to 900 South, to serve SLC’s Granary District | 13 | 14 | 9 | 5 | 5 | 2 | 48 |

1.2.2 2022 On-Line Survey

UTA also used e-mail “blasts” to customers and other local interested parties to engage them through its web site and FOLR content. This allowed for more free-form commenting on light rail/streetcar priorities as well as to identify the most promising improvements from the “pop-up” board. As with the face-to-face engagement, the “B – Offer all night service on the new Orange Line from downtown to the Salt Lake International Airport” improvement scored highest of the 72 responses received. This is based on UTA review of the comments and their specific improvement mentions, in the sense that they were liked options or were specifically ranked as highest priority.

The scores for the highest-ranked improvement were:

- + A-13
- + B-31
- + C-17
- + D-9
- + E-9
- + F-15
- + G-25

2 Recommendations

1) Continue analysis for potential **service expansion and reconfiguration**

- a. Future of Light Rail (FOLR) study provides data and analysis to support the TechLink study which will consider the following expansion options in more detail
 - i. 400 South between Salt Lake Central and Main Street
 - ii. Extension to Research Park
 - iii. Extension to Ballpark Spur and 400 West

2) Optimize **fleet efficiency**

- a. Replace first generation high-floor cars with low-floor cars with similar length of S70s
- b. Recommended service expansion could be accommodated with the addition of 4 additional cars by RTP Phase 3
 - i. Travel demand forecasts and UTA Service Standards support 3-car standard length train on all services
 - ii. Assumes reduction in UTA's current spare margin; maintains a 20% spare ratio

3) Fund Key **infrastructure renewal/improvement** projects

- a. Trunk line speed improvements
- b. Service reliability improvements
 - i. Central Pointe (Union) interlocking turnback and connecting track from west to south
 - ii. 400 West (Pioneer Park) Connector
- c. Traction power upgrades

4) Collaborate with partners to **improve transit signal priority (TSP)**

- a. Reduce delay through 19 critical intersections
- b. Continue coordination with the owners and maintainers of the applicable intersection traffic control devices – UDOT, Salt Lake City, and West Valley City traffic engineering

5) Enhance span of service

- a. Initiate negotiations to reduce freight railroad/increase TRAX operating windows as part of existing temporal separation agreement
- b. Continued analysis for extended span where possible

Action Items

- + Planning and Capital Development:
 - + Continue discussions with UDOT, West Valley City, and Salt Lake City on TSP improvements
 - + Perform comprehensive U.S. Title VI equity and environmental justice analysis before advancing any TRAX service changes
 - + Integrate recommended small-scale infrastructure improvements into maintenance and budget planning
 - + Advance TechLink Corridor Study informed by relevant results of analysis from the FOLR Study

3 System Expansion

The long list of FOLR system expansion comments included three alternative expansions of the S-Line Streetcar at its eastern end, two Point of the Mountain light rail alternatives and a downtown streetcar connecting Salt Lake Central, Temple Square and President's Circle at the University of Utah. A new transit corridor proposed by the University of Utah to serve the growing Research Park area south of the University was also included in the long list of potential system expansion opportunities. The UTA TechLink Corridor Study⁷ will make the final determination on mode for a future transit extension to Research Park; for the purpose of analysis for the FOLR Study, light rail was assumed in order to understand potential impacts to the rest of the TRAX system.

A number of "infill" concepts, including conversion of the Ballpark Spur to light rail, extension of the 400 South/University Line westward to Salt Lake Central and conversion of the half grand union at 400 South/Main Street to a full grand union were also considered. In the end, the expansion alternatives dropped out, either because of disappointing modeling results during the Study or, in the case of Point of the Mountain, due to a recommendation to advance BRT instead of rail.⁸

In the end, the "infill" concepts came together as part of the Strategic Plan recommendations that would:

- + Serve the Granary District's anticipated growth in residential and business uses with light rail transit connecting Salt Lake Central, the University, the Airport, and the Red/Blue/Green cities to the south and west
- + Add four or five new TRAX stations in the Granary District
- + Allow introduction of a fourth TRAX service at the capacity-constrained 400 South and Main Street intersection that can accommodate all the travel modes passing through this intersection
- + Extend the TRAX network with a new branch to the University of Utah's Research Park area diverging from the existing University Line near Rice Eccles Stadium
- + Enhance system efficiency such that the Orange Line could be added between the University and Salt Lake Central with no new fleet and with minimal increase in annual operations and maintenance costs.

Figure 4 shows the long-term TRAX network recommended by the Strategic Plan. New light rail segments on the Ballpark Spur, through the Granary and at Research Park are highlighted in yellow. The recommended service routes and designations are also shown with each of the three existing TRAX lines rerouted in some fashion and the new Orange Line added between the University, Salt Lake Central and the Airport. Changes to the three existing lines include:

- + Red Line: Maintains its existing terminal endpoints but is rerouted via the new Ballpark Spur and 400 South westward extension to serve new markets in the Granary and to avoid the capacity-consuming turning movement at 400 South/Main Street
- + Blue Line: Operates to the Airport instead of Salt Lake Central, increasing TRAX system ridership versus the current northern termini of the Blue and Green Lines
- + Green Line: Operates to Salt Lake Central instead of the Airport

⁷ [TechLink Corridor Study \(rideuta.com\)](https://rideuta.com/techlink-corridor-study)

⁸ More recently, the Point of the Mountain Transit Study has reopened consideration of rail alternatives and is currently considering both light rail and diesel multiple unit technologies; neither would physically connect to the TRAX network.

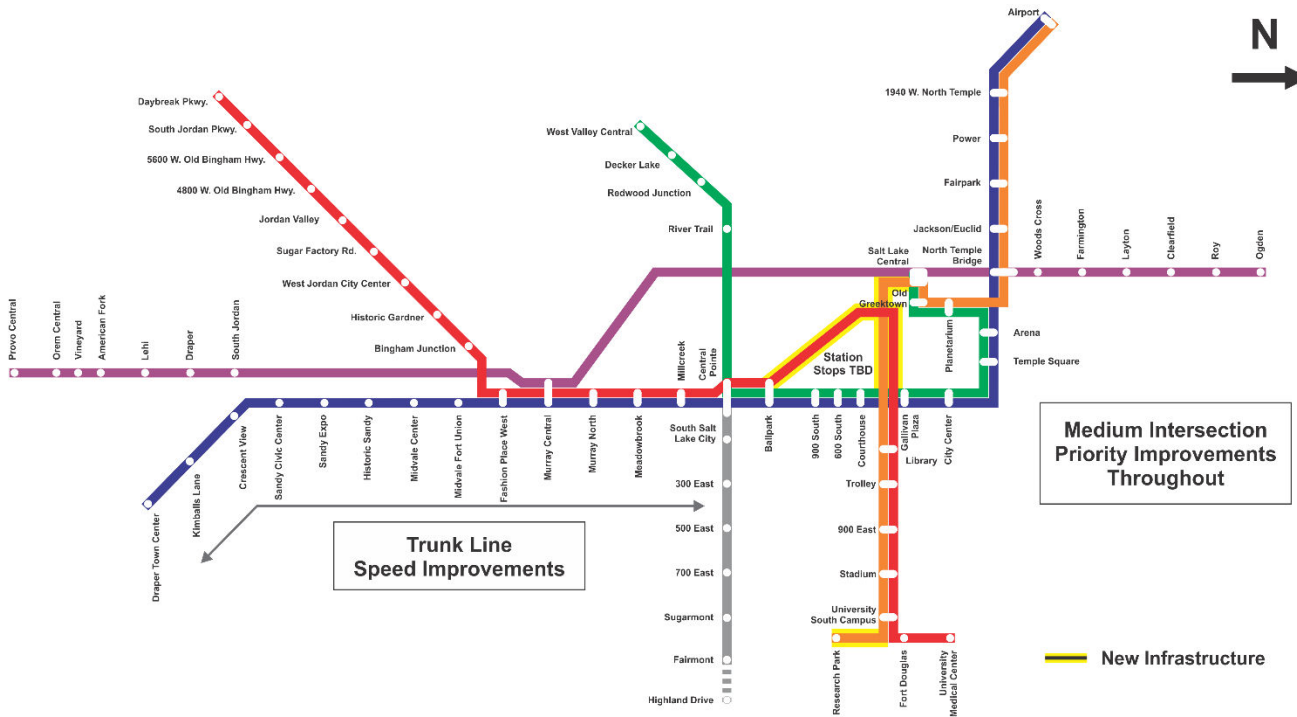

Figure 4 – Strategic Plan recommended future network (system expansion highlighted in yellow)

The FOLR Study team developed a concept design for the Granary District Ballpark Spur and 400 South Extension based on a conceptual track layout proposed by the Light Rail Business Unit. The design features two-track street or median operation throughout. Although highly conceptual in nature, a total of five new light rail stations are included in the concept design; these are subject to refinement as UTA’s TechLink Study gets underway.

Table 2 provides a high-level summary of the recommended TRAX system expansion that comprises 400 South (west of Main Street), the Ballpark Spur and connections to Salt Lake Central via the Granary District. Refer to Appendix D for information on the Study’s capital cost estimating methodology. Refer to Appendix E for more information on the concept design effort for these improvements.

| Table 2 – 400 South/Ballpark Spur/Granary District System Expansion Capital Cost Summary | | |
|--|-----------------|-------------------------|
| Cost Category | Capital Cost | Percent of Project Cost |
| Guideway and Track | \$25.2 million | 20.3% |
| Stations | \$20.6 million | 16.7% |
| Sitework | \$9.4 million | 7.6% |
| Systems | \$22.3 million | 18.0% |
| Right of Way | \$1.3 million | 1.1% |
| Professional Services | \$16.5 million | 13.3% |
| Unallocated Contingency | \$28.6 million | 23.1% |
| Total | \$123.9 million | 100% |

The initial design concept featured a connection on 400 West to the existing Blue Line’s approach to Salt Lake Central from the north. During the Strategic Plan development process, this was modified to approach Salt Lake Central from the south, via 400 South and 600 West. Still later, the segment on 400 West adjacent to Pioneer Park was added back to the Strategic Plan’s recommendations as a non-revenue connector. This two-block non-revenue connector between 400

West/400 South and 400 West/200 South has a half grand union at its northern end and a full grand union connector at its southern end. Refer to Appendix F for more information on the 400 West (Pioneer Park) Non-Revenue Connector.

A revised connection from the Ballpark Spur to Salt Lake Central was developed to provide a more direct approach to Salt Lake Central via 400 South/600 West. This allows through running operation, such as interlining of the proposed Orange Line with the existing Green Line or proposed Strategic Plan Blue Line operation. Because of the 400 South viaduct approach crossing the FrontRunner and Union Pacific tracks, there are limited options at this location. The Study evaluated all-north, all-south and a straddling (one light rail track on each side of the viaduct) alignments at this location (refer to Appendix E for more information). The TechLink Corridor Study will evaluate the overall Granary District alignment, including the complex trade-offs in the vicinity of 400 South/600 West.

The other System Expansion element included in the Light Rail Strategic Plan is a 0.55-mile branch serving the University of Utah's Research Park area. The branch would diverge from the Red Line east of Rice-Eccles Stadium and serve one new station at the heart of Research Park. In addition to supporting the new Orange Line service between the University, Salt Lake Central and the Airport, the new Research Park terminus would provide important special events service capabilities, allowing UTA to better serve "surge" ridership demands at the start and end of major sporting and entertainment events. Table 3 provides a high-level summary of the Research Park Branch capital costs. Refer to Appendix G for more information on the Research Park Branch concept design.

| Cost Category | Capital Cost | Percent of Project Cost |
|-------------------------|-----------------------|--------------------------------|
| Guideway and Track | \$4.6 million | 15.0% |
| Stations | \$4.1 million | 13.6% |
| Sitework | \$2.1 million | 6.8% |
| Systems | \$8.1 million | 26.7% |
| Right of Way | -- | -- |
| Professional Services | \$4.5 million | 14.8% |
| Unallocated Contingency | \$7.0 million | 23.1% |
| Total | \$30.4 million | 100% |

4 TRAX Fleet Plan

4.1 Purpose of the TRAX Fleet Plan

The FOLR Study includes updating of the Light Rail Fleet Plan in consultation with the UTA. The purpose of the Fleet Plan is to ensure a future sufficient, reliable and cost-effective light rail fleet. As part of cost-effectiveness considerations, the Fleet Plan considers fleet capital costs, and operations and maintenance costs. It also considers daily service and inspection, maintenance repair and periodic overhaul work, all of which are performed by the two Light Rail Service Centers. These are located on the Green Line just west of Central Pointe Station (the Jordan River Service Center) and on the Red Line just southwest of Fashion Place West Station (the Midvale Rail Service Center).

Other considerations in developing the Fleet Plan are to ensure federal eligibility for capital funding of future line extensions and other service expansions. The Fleet Plan considers fleet alternatives that increase quality of service. These alternatives include longer vehicles that reduce maintenance complexity (because there are fewer operating controls to maintain) and encourage greater passenger separation, an important consideration in recovering from the COVID-19 pandemic.

Table 4 shows the current TRAX fleet including the three vehicles configured for operation on the S-Line Streetcar. The typical life expectancy of a light rail vehicle is 30 to 35 years so the SD100 and SD160 vehicles will be due for retirement and replacement in the next 7 to 14 years.

| Model | Manufacturer | Quantity | In-Service Date | Configuration |
|----------------------|---------------------|-----------------|------------------------|----------------------|
| SD100 | Siemens | 23 | 1999 | High Floor |
| SD160 | Siemens | 17 | 2001 | High Floor |
| S70 | Siemens | 74 | 2011 | 70% Low Floor |
| S70 Streetcar | Siemens | 3 | 2011 | 70% Low Floor |

4.2 Train Length Considerations

All three Light Rail Vehicle (LRV) models that comprise today’s UTA light rail fleet are 81 feet in length and are termed “ultra short LRVs” by their manufacturer, Siemens. With a maximum train length of four cars, many elements of the UTA light rail infrastructure – station platforms, yard tracks, terminal tracks, maintenance facilities – are designed around a 324-foot train length. It is important that any future UTA fleet be consistent with this train length. Global light rail vehicle trends in recent years have been towards longer light rail cars; this is not necessarily inconsistent with the UTA-standard 324-foot train length. As shown in Figure 5, this length can be satisfied with four 81-foot cars, three 108-foot cars or two 162-foot cars. The longer car lengths are accommodated with additional articulations, increasing the existing UTA two-segment vehicles to three or four segments. As the FOLR Study was concluding, UTA made the decision to move forward with replacement of the SD100/SD160 fleet with new 81-foot cars.

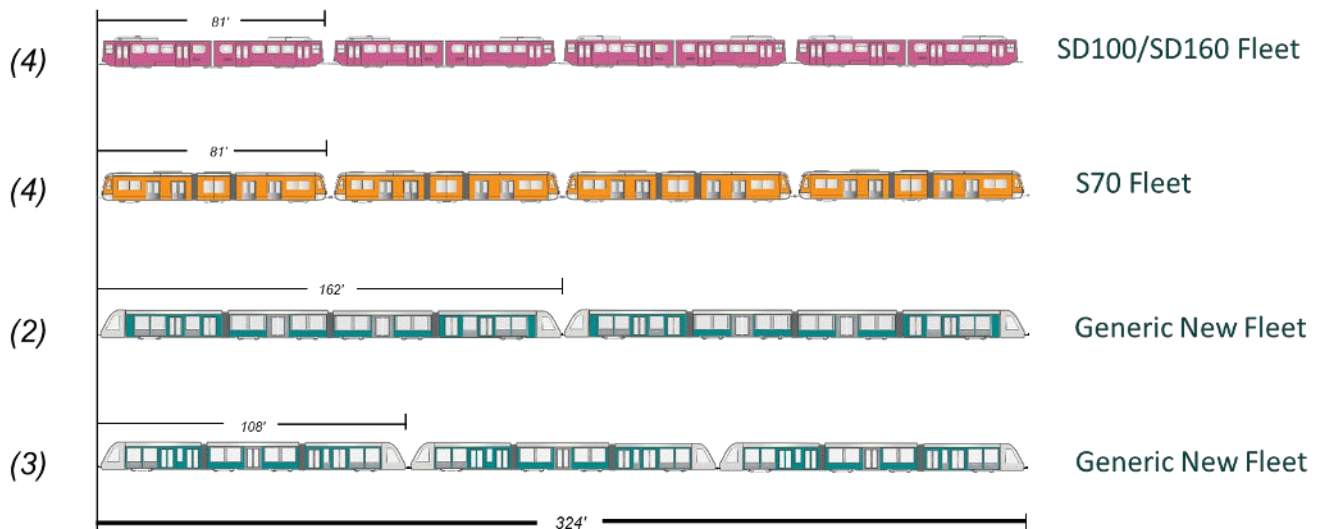

Figure 5 – Equivalent Train Consists – Maximum Length Train (324')

4.3 Car Floor Height and Accessibility Considerations

Today's UTA fleet consists of high floor models (SD100 and SD160) and 70% low floor models (S70). Accessibility for high floor models is achieved through the use of a "high block" boarding platform that provides access to the front portion of the train. A stand-alone bridging plate deployed by the Train Operator is used to address the small gap between high block and car for those UTA customers using mobility devices. Stations on the Blue Line (including the North/South Line) and a limited number of other locations are equipped with high blocks.

The newer 70% low floor vehicles, used in all Red and Green Line trains, allow level or nearly-level boarding at each car in the train. A deployable motorized bridging plate is available to customers using mobility devices at all doors. The 70% low floor cars provide greater accessibility by providing access to all cars in the train, eliminating congestion on the high block boarding platform as well as dependence on the Train Operator to manually deploy a bridging plate.

An important consideration with respect to replacement of the SD100/SD160 high floor fleet is eligibility for potential Federal Transit Administration (FTA) funding. The FTA no longer considers the use of high blocks to represent a fully-accessible solution. Therefore, UTA would need to replace its high floor fleet with a partially or fully low floor fleet in order to secure FTA funding for any potential Blue Line extension in the future or for the Blue Line to service stations that do not have high blocks such as on North Temple, as recommended by the Light Rail Strategic Plan.

Furthermore, UTA Light Rail Operations indicates that high block boarding locations can suffer from crowding, especially during special events and the holiday season. UTA's current policy is that anyone who feels they need to use a high block boarding location is free to do so except that customers with bicycles are asked to board at any of the non-high block locations. In addition to customers using mobility devices, high blocks are used by customers experiencing difficulty in climbing stairs, those with large suitcases and those with strollers as well as the people accompanying them. Similarly, these customers can experience crowding in the light rail vehicle as they must remain within communicating distance of the Train Operator in order to ensure that the bridging plate is manually deployed at their destination station.

The 70% low floor models also provide modestly lower dwell times than do the high floor vehicles. The Study team utilized a large 2019-2020 dataset of UTA APC data to compare average dwell times of more than 15,000 trips operating in each direction for each of the three lines. With such a large dataset, variability in terms of intersection delay and other external factors is eliminated in the dwell time comparison. Table 5 shows that the high floor trains on the Blue Line typically have dwells three to four seconds longer than the 70% low floor trains on the Red and Green Lines. The only exception is southbound Green Line operation at Ballpark Station where Green Line operations have extended dwells

due to the need for Train Operators to make a required route call, a distinction not relevant to high block versus platform length accessibility boarding.

| Table 5 – UTA APC-Recorded Dwell Time Differences – High Floor Trains vs. 70% Low Floor Trains | | | |
|--|----------|--------------|-------------------------|
| Station | Service | Observations | Average Dwell (Seconds) |
| 900 South | Green NB | 15661 | 25.7 |
| | Red NB | 16842 | 25.5 |
| | Blue NB | 17499 | 29.1 |
| | Green SB | 15609 | 25.5 |
| | Red SB | 16913 | 26.2 |
| | Blue SB | 17525 | 29.1 |
| Ballpark | Green NB | 15691 | 24.5 |
| | Red NB | 16905 | 23.9 |
| | Blue NB | 17529 | 27.5 |
| | Green SB | 15796 | 44.0* |
| | Red SB | 17024 | 26.9 |
| | Blue SB | 17562 | 29.6 |

* Extended due to required route call

The shorter Red and Green Line dwells would translate into a minute or more of travel time savings for Blue Line operation when applied to the entire line from end-to-end. This is due to elimination of Train Operator duties associated with the high block as well as greater overall boarding efficiency for customers who do not need to negotiate steps up or down.

As the FOLR Study was concluding, UTA made the decision to move forward with replacement of the SD100/SD160 fleet with new 70% or greater low floor cars. Such cars can operate at Blue Line stations without removing the high blocks; no specific capital funding has been programmed for removal of the high blocks at this time. In addition to the accessibility benefits noted above, the 70% or greater low floor cars will be more convenient for passengers traveling with e-bikes, which are typically much heavier than traditional bikes.

4.4 TRAX Fleet Plan Next Steps

At the conclusion of the Light Rail Strategic Plan, UTA decided to proceed with replacement of the first-generation fleet with 40 new 81-foot vehicles. UTA’s Request for Proposal will leave open the possibility of 70% low floor (the entire car floor area except for the end truck locations) or 100% low floor. UTA is budgeting \$6.25 million per car in current year dollars, bringing the total estimated contract cost to \$250 million.

The pre-COVID UTA peak fleet requirement is 87 cars (excluding streetcar fleet requirements of two cars). When the UTA (and industry) target spare margin of 20% is added to this, the resultant overall fleet requirement is 105. This is slightly less than the current light rail fleet total (excluding the three S70 streetcars) of 114 cars. In other words, the 27 cars not presently required to deliver peak service of 87 cars represents a spare margin of about 31%. With ridership growth in the Future Baseline, the fleet requirement increases to 133 cars, including the standard 20% spare margin. This equates to a required fleet increase of 16 cars; however, the more efficient fleet utilization of the service plan recommended in the Strategic Plan does not require such a significant fleet expansion.

Table 6 – Projected Light Rail Strategic Plan Fleet Requirements

| Service | Future Baseline | | Strategic Plan (Full – RTP Phase 3) | | Strategic Plan (Interim – RTP Phase 2) | |
|--|-----------------|------------|--|------------|---|------------|
| | Trains | Cars/Train | Trains | Cars/Train | Trains | Cars/Train |
| Blue Line | 11 | 4 | 10 | 3 | 10 | 3 |
| Red Line | 12 | 4 | 10 | 3 | 10 | 3 |
| Green Line | 8 | 2 | 7 | 2 | 7 | 3 |
| Orange Line | -- | 0 | 8 | 3 | 4 | 3 |
| S-Line Streetcar | 2 | 1 | 2 | 1 | 2 | 1 |
| Total Peak Cars | 110 | | 100 | | 95 | |
| Total Fleet Requirement (with 20% Spares) | 133 | | 121 | | 115 | |
| New Cars Required | 16 | | 4 | | (2) | |

Compared with today's fleet utilization, the Strategic Plan spare margin is assumed to be reduced to 20%, allowing some service expansion without commensurate fleet acquisition as shown in Table 7. The full Strategic Plan, including two-line service to the Airport as embodied in RTD Phase 3, requires a total of 121 cars, including the industry standard 20% spare margin. This is an increase of 4 LRVs when compared with today's fleet, as shown in Table 6. UTA can address the need for expanded fleet by including provisions for options within the first-generation light rail vehicle replacement RFP now under development. This is a standard consideration in most agency vehicle procurements. Were UTA to forego this fleet expansion but opt to implement the full Light Rail Strategic Plan, the spare margin would drop to an unacceptably low 17%, as shown in Table 7.

Table 7 – Projected Light Rail Strategic Plan Vehicle Spare Margin with and without Additional Fleet

| Future Planning Horizon | Assumed Additional Fleet | Branch Headways (Minutes) | Spare Margin |
|--|-----------------------------|------------------------------|-----------------|
| Light Rail Strategic Plan (Interim – RTP Phase 2) | 0 | 15 | 23% |
| Light Rail Strategic Plan (Full – RTP Phase 3) | 0 | 15 | 17% |
| Light Rail Strategic Plan (Full – RTP Phase 3) | 4 | 15 | 20% |

5 Recommended Infrastructure Renewal and Improvements

The Strategic Plan recommends four TRAX infrastructure renewal and improvement projects to reduce travel times, enhance system reliability, avoid technological obsolescence, better support “surge” ridership at special events and reduce operating costs. The project costs and benefits are summarized in Table 8. Two of the recommended infrastructure renewal projects and improvements are specifically targeted at improving system reliability in the event of delays/failures while also supporting UTA in more effectively serving major special events in the Ballpark and downtown areas. These improvements are the Union Turnback Track/Green Line West to South Connection and the 400 West (Pioneer Park) Non-Revenue Connector.

Separately, UTA has been advancing analysis of traction power State of Good Repair improvements. This analysis uses traction power load flow simulation to identify deficiencies in the TRAX DC power network and to recommend improvements that will resolve them. UTA’s work in this area is also described in this chapter; the associated capital investments are included in the overall Light Rail Strategic Plan capital cost.

| Table 8 – Recommended Infrastructure Renewal and Improvements | | |
|---|------------------------|---|
| Recommended Improvement | Estimated Capital Cost | Benefits |
| Trunk Line Speed Improvements | \$21.4 million | Reduces travel times between Draper and Ballpark by 4 minutes in each direction |
| Union Turnback Track and Green Line West to South Connection | \$13.1 million | Improves operational efficiency and capacity by allowing non-revenue movements directly from Jordan River to Trunk Line stations south of Central Pointe, improves reliability by adding a strategic location to hold a train requiring maintenance, increases ability to support “surge” ridership after special events at Ballpark and downtown |
| 400 West (Pioneer Park) Non-Revenue Connector | \$16.4 million | In conjunction with the Strategic Plan’s recommendation to upgrade the Ballpark Spur for revenue service, replaces this track as a location to stage special events trains. Improves reliability by providing an alternative route to Main Street and to Salt Lake Central in the event of operational disruptions and by adding a strategic location to hold a train requiring maintenance |
| Traction Power System Upgrades | \$3.7 million | Improves reliability of the traction power system by replacing components approaching the end of their useful lives, by increasing the ability to remotely control key sectionalizing switches and by resolving technological obsolescence issues (lack of supplier product support, lack of spare parts availability) |

5.1 Trunk Line Speed Improvements

The Strategic Plan recommends upgrading the original Trunk Line from Ballpark Station, where it enters dedicated right-of-way to the south, to Sandy Civic Center and Draper Town Center, to 65 mph operation where feasible. These upgrades, requiring coordination of track alignment, stations, grade crossings, signaling and Overhead Contact System (OCS), can be implemented incrementally as part of on-going State of Good Repair work. In their entirety, the speed upgrades will reduce travel times by 4 minutes in each direction, a significant improvement. Most of the travel time savings are realized only after the original high floor vehicle fleet is replaced as the current SD100 high floor fleet has a maximum speed of 55 mph.

Depending on location, the Trunk Line speed improvements require adding super-elevation to curves (increasing the height differential of the two rails to support faster speeds), modifying curve spirals or, in some cases, simply recomputing appropriate speeds for existing curve geometry based on the updated UTA design criteria. The intent of these changes is to reduce travel times without shifting track locations, acquiring additional right-of-way, relocating catenary poles or requiring significant station work. The higher speeds may require some signal system changes as the signal design safe braking distance was assumed to be 55 mph at the time the signal system was designed.

The UTA Trunk Line is the original light rail line opened from downtown Salt Lake City to the communities of South Salt Lake, Murray, Midvale, and Sandy. The line opened in 1999 with a southern terminus of Sandy Civic Center. In 2013, the line, designated the Blue Line as the system was expanded, was extended from Sandy Civic Center to Draper Town Center, following the alignment of a disused Union Pacific freight line that formerly connected Salt Lake City with Provo.

UTA’s design criteria at the time of original light rail design called for a maximum design speed of 55 mph. This was consistent with the maximum operating speed of UTA’s original light rail fleet, the Siemens SD100s, as well as with light rail industry standards across North America. As additional light rail segments entered the planning and design stages, especially the Red Line from Fashion Place West to Daybreak Parkway, UTA design criteria for maximum system speed was increased to 65 mph. The more recent light rail vehicle procurement of Siemens S70s brought higher speed capability to the UTA light rail fleet.

| Table 9 – Trunk Line Speed Improvements Capital Cost Summary | | |
|--|----------------|-------------------------|
| Cost Category | Capital Cost | Percent of Project Cost |
| Guideway and Track | \$12.0 million | 56.2% |
| Stations | \$0.3 million | 1.2% |
| Sitework | \$1.3 million | 6.2% |
| Systems | \$1.8 million | 8.5% |
| Right of Way | -- | -- |
| Professional Services | \$1.0 million | 4.8% |
| Unallocated Contingency | \$4.9 million | 23.1% |
| Total | \$21.4 million | 100% |

Refer to Appendix H for more information on the Trunk Line Speed Improvements.

5.2 Union Turnback Track and Green Line West to South Connection

Currently, all TRAX trains needing to go south from, or north to, the Jordan River Service Center on the main North/South line have to pull into Central Pointe Station for the operator to change train ends in order to reverse direction. This reversing process takes approximately four minutes and, with a train passing through the station every 2 to 3 minutes on average, can cause system delays. The proposed project would allow for such trains to avoid this special maneuver by constructing a track connection in the southwest quadrant of the junction between the North/South Line and the Green Line. The Green Line West to South Connection would allow straight-through movement between the North/South Line and the Green Line, which provides access to the Jordan River Service Center.

The project would also construct a four-car siding or turnback track on the west side of the North/South Line. This track would serve three operational purposes:

- + Support holding a non-revenue train destined for the Green Line or destined for the North/South Line until a delay-free operating slot is available without delaying following revenue trains on the line being exited
- + Allow the staging of a special events train for Ballpark Station or other downtown stations without blocking the North/South Line
- + Temporarily holding a train that was unexpectedly removed from service due to a vehicle issue until it can be operated (or towed) to Midvale or Jordan River

The UTA Light Rail Business Unit desires this project, and it is currently included on the future State of Good Repair list. However, the project is not presently scheduled or funded. The project would not directly improve travel time or capacity; however, it would improve system reliability, as measured by OTP, as well as operational flexibility. The project would improve operational efficiency by eliminating the time-consuming reversing move at Central Pointe Station for

both morning train put-ins and evening train lay-ups. It would also eliminate the reversing move for non-revenue train movements that commonly occur as vehicles are shuttled between Jordan River and Midvale Service Centers.

The existing R.C. Willey Appliance Warehouse freight siding would need to be relocated to the south in order to provide sufficient room for the siding/turnback track. The siding/turnback track is connected to the mainline with No. 6 turnouts, suitable for light rail operations but not usable by freight trains (such as freight locomotive running around its train to change direction). The turnout at the south end of the siding/turnback track is located south of the grade crossing while a maximum length (four-car) train would fit north of the crossing. The southbound interlocked home signal would be located immediately north of the grade crossing and would be interfaced with the crossing warning systems such that the flashers would activate and gates would descend as soon as the TRAX dispatcher cleared a southbound route from the siding/turnback track. For northbound trains accessing the siding/turnback track from the south, the existing Yellowstone Interlocking crossovers on the North/South Line would be used so that the northbound train would operate a short section on the normally-southbound track before diverging to the new track.

Table 10 – Union Turnback Track and Green Line West to South Connection Capital Cost Summary

| Cost Category | Capital Cost | Percent of Project Cost |
|-------------------------|----------------|-------------------------|
| Guideway and Track | \$2.8 million | 21.1% |
| Stations | -- | -- |
| Sitework | \$0.6 million | 4.3% |
| Systems | \$4.6 million | 35.4% |
| Right of Way | \$0.6 million | 4.2% |
| Professional Services | \$1.6 million | 11.9% |
| Unallocated Contingency | \$3.0 million | 23.1% |
| Total | \$13.1 million | 100% |

The \$13.1 million total estimated cost of the project is summarized in Table 10. The major cost components are trackwork, signals and Overhead Contact System (OCS). The estimate includes \$0.4 million (prior to allocation of contingencies) for property taking and partial demolition of the building in the southwest quadrant of the connection. The cost of reconstructing the R. C. Willey freight siding is included but no financial compensation to the property owner for this change is assumed. The total estimated cost of the project includes 30% allocated contingency for each of the first five cost categories (included in the values shown in the table) as well as additional professional services costs and unallocated contingency shown separately in the table.

Refer to Appendix I for more information on the concept design and a detailed capital cost estimate.

5.3 400 West (Pioneer Park) Non-Revenue Connector

Phase 2 of the FOLR Study evaluated how best to serve the Granary District and Salt Lake Central. The Phase 1 Ballpark Spur/400 South concept which served Salt Lake Central from the north (by joining the existing Blue Line at 400 West/200 South) was revised to serve Salt Lake Central from the south. This includes additional westward TRAX extension on 400 South, turning northward on 600 West. This eliminated the short segment on the west side of Pioneer Park from 400 South to 200 South.

Subsequently, the UTA Light Rail Business Unit requested that this two-block segment be restored to the Plan with the understanding that it would be used as a non-revenue connector. It would provide system resiliency in the event of a blockage at Salt Lake Central or on Main Street by allowing trains to be routed around closed or blocked tracks (thus reducing the possible need for a bus bridge) and would provide the ability to stage non-revenue trains awaiting the end of a special event at the arena or Temple Square. Finally, the Light Rail Business Unit felt that the connector could serve as a location to “pocket” a disabled train, with access from the Ballpark Spur, 400 South and Main Street (currently the Ballpark Spur is used as a location to “pocket” a disabled train, but with that track becoming mainline track as

recommended in this Strategic Plan, an alternate emergency storage location is needed). On this basis, the project was included in the Strategic Plan. Because the non-revenue connector does not support regularly-scheduled service, its benefits were not captured through rail network simulation.

The estimated cost of the two-block connector is summarized in Table 11; refer to Appendix F for a more detailed capital cost estimate using FRA Standard Cost Categories. The 0.37-mile connector has been assigned its pro rata share of traction power substation costs, consistent with other FOLR capital cost estimates. The need for and siting of a new traction power substation would require a traction power load flow study to determine. The major cost components in the \$16.4 million estimated cost are trackwork, signals and Overhead Contact System (OCS), as well as the pro rata share of new substation costs. Signals cost assumes that the connector is built at the same time as other Granary District TRAX improvements with half grand union at 400 South/400 West upgraded to a full grand union and a new half grand union constructed at 200 South/400 West. The total estimated cost of the project includes 30% allocated contingency for each of the first five cost categories (included in the values shown in the table) as well as additional professional services costs and unallocated contingency shown separately in the table.

| Cost Category | Capital Cost | Percent of Project Cost |
|-------------------------|-----------------------|--------------------------------|
| Guideway and Track | \$5.7 million | 34.9% |
| Stations | -- | -- |
| Sitework | \$1.4 million | 8.5% |
| Systems | \$3.8 million | 28.5% |
| Right of Way | -- | -- |
| Professional Services | \$1.7 million | 10.1% |
| Unallocated Contingency | \$3.8 million | 23.1% |
| Total | \$16.4 million | 100% |

5.4 TRAX Traction Power System Improvements

UTA commissioned a two-part traction power load flow study in 2020 that was performed independent of the FOLR Study. The results were shared with the Study team and provide insights into the ability of the TRAX traction power system to support existing and future light rail service levels.

In addition to evaluating the robustness of the existing traction power system, the study was designed to inform the specification of replacement DC substations for the 18 units installed on the original Blue Line. These substations were furnished by Impulse, are more than 20 years old and approaching the end of their normal life cycle (the remaining substations on TRAX were manufactured more recently by Siemens and are approximately six to 10 years old).

The traction power study did not evaluate closer train headways than operate at present so it does not provide insights into the feasibility of operating 4-minute trunk headways (12-minute branch headways) instead of the current 5-minute trunk headways (15-minute branch headways). Such closer headway operation was evaluated in FOLR Phase 1 but ultimately was not included in the Light Rail Strategic Plan.

The UTA traction power study did investigate two service enhancements:

- + Increasing train length on the Green Line from the present 2-car consist to 4 cars
- + Operation of a new Orange Line service on existing UTA tracks between the University and Salt Lake Central (note that this Orange Line differs from that included in the Strategic Plan as the traction power study’s assumption of turning movements at 400 South/Main St were deemed infeasible based on TrainOps operations simulation)

The traction power system load flow model covered about 80 to 85 % of the TRAX system. The outlying segments of the Mid-Jordan, West Valley and Airport Lines were not modeled as they are the newest segments of the network and support only a single service on each line. The study did not estimate any capital costs for traction power State of Good Repair or capital improvements.

5.4.1 Traction Power System Pass/Fail Performance Criteria

For operations with all substations in-service, the minimum train voltage from the load flow simulations was considered unacceptable if it fell below 600 Vdc. For contingency operations (where a substation is out of service due to a failure or while undergoing routine maintenance), the train voltage must not fall below 525 Vdc for a significant time period. This criterion reflects a trade-off between the traction power system's capital cost and the operating reliability of the TRAX network.

Another pass/fail criterion in the load flow study was that no substation transformer/rectifier unit can be overloaded based on industry standard criteria. Overloading risks thermal damage and premature failure of the unit.

5.4.2 Traction Power Load Flow Model Results and Key Findings

The study expresses concern about the loading of the downtown single contact wire configuration. This is a 1.7-mile portion of the line where the overhead contact wire is reinforced with an underground feeder connected to the contact wire via cable risers at intervals of about 500 feet.

The study notes that the normal simulated operations find that train voltages routinely fall below the 600 Vdc threshold but stay above the 525 Vdc cut-off where performance is significantly affected. The study noted that, under contingency operations, the minimum train voltage criteria was met for all substation outage conditions. For special event operations, the minimum voltage requirements were not satisfied when any one of eight substations is out-of-service. The three most concerning substation contingency cases were when Substations SRN3, SRC7 or SRN13 were off-line.

The study did not find any substation overloading. However, with the Orange Line in service on existing tracks, Substations SRC7, SRT2 and SRD1 were found to be operating for the evening peak period at 96% to 98% of their nominal current rating, which is very close to being overloaded.

Phase 2 of the UTA traction power study recommends that a minimum of nine of the original Impulse substations be replaced with larger units, resolving the overloading conditions found in the Phase 1 modeling. In addition, all new substations are recommended to have a higher nominal voltage and improved voltage regulation characteristics versus the units being replaced. They are also recommended to have a capacity rating of 2000 kW which, again, reflects upgrades versus the units being replaced.

Since the completion of the traction power load flow study, UTA has moved forward with procurement of many traction power upgrades for the TRAX network. They are summarized in Table 12. These costs are not included in the Strategic Plan budget as funding has already been secured for this work.

| Table 12 – UTA Light Rail Traction Power Projects Funded/Underway | |
|---|--|
| Location | Description |
| Downtown (Vivant Arena-Temple Square-Arena) | Replace Underground 500 MCM Parallel Feeder Cables |
| TPSS – SRD1 Delta Center Substation | (+)2MW Transformer, (+) 2 Additional DC Breakers |
| TPSS – SRT2 300 South Substation | (+)2MW Transformer, (+) 2 Additional DC Breakers |
| TPSS – E1 200 East Substation | Base Substation Upgrade |
| TPSS – E2 900 East Substation | Base Substation Upgrade |
| TPSS – E3 University Substation | Base Substation Upgrade |
| TPSS – E4 Fort Douglas Substation | (+)2MW Transformer (More Capacity) |
| TPSS – E5 Medical Center Substation | Base Substation Upgrade |
| TPSS – SRN3 900 South Substation | (+)2MW Transformer, (+) 2 Additional DC Breakers |
| TPSS – SRB4 Burton Substation | (+)2MW Transformer, (+) 2 Additional DC Breakers |
| TPSS – SRH5 Hustlers Substation | (+)2 Additional DC Breakers |
| TPSS – SRW6 Walton Substation | (+)2MW Transformer, (+) 2 Additional DC Breakers |
| TPSS – SRC7 Central Substation | (+)2MW Transformer, (+) 2 Additional DC Breakers |
| TPSS – SRM8 Murray Substation | (+)2MW Transformer, (+) 2 Additional DC Breakers |
| TPSS – SRP9 Pallas Yard Substation | (+)2 Additional DC Breakers |
| TPSS – YRY1 Collet (Midvale Service Center) Yard Substation | Base Substation Upgrade |
| TPSS – SRA 10 Atwood Substation | Base Substation Upgrade |
| TPSS – SRS11 Sugar Highway Substation | Base Substation Upgrade |
| TPSS – SRR12 Rio Grande Substation | (+)2MW Transformer (More Capacity) |
| TPSS – SRN13 9400 South Substation | Base Substation Upgrade |
| TPSS – SRJ14 Jordan Substation | (+)2MW Transformer (More Capacity) |

UTA Systems Engineering has also identified the need for additional traction power breakers to better sectionalize the system in case of fault. These additional breakers not only provide more flexibility to de-energize individual sections of track remotely, but they also enhance the protection functions of the substations when a catenary wire fails. UTA indicated the decision to recommend more breakers was also a consequence of the rated capacity increase in the replacement substations.

5.4.3 Overhead Contact System Key Findings

The UTA traction power study finds that the OCS is adequate from thermal load point of view, except for a short contact-wire-only section at the “University Junction” half grand union at the Main St/ University Blvd intersection. This thermal overloading occurs only when the OCS sectionalizing gaps are closed. The study notes that overheating of the contact wire is undesirable, potentially resulting in premature failure of the wire. The study presents two alternatives for resolving the potential overheating issue.

5.4.4 Traction Power Capital Costs

In August of 2022, UTA Systems Engineering indicated that its traction power system upgrade capital costs are still at the planning level. It provided the following capital cost estimates:

- + Addition of remote monitoring to disconnect switches: \$0.4 million
- + Upgrade protection, control, and monitoring capabilities of second generation (Siemens) substations: \$1.5 million
- + HVAC upgrades to first generation (Impulse) substations: \$1.3 million
- + Remote stray current monitoring and mitigation: \$0.6 million
- + Total: \$3.7 million (total reflects rounding)

The specific improvements are shown in Table 13. The Study team has included UTA Systems Engineering’s planning level cost estimate in the Strategic Plan budget but has not developed an accompanying independent capital cost estimate.

| Table 13 – UTA Light Rail Traction Power Desired/Planned Projects (Unfunded) | |
|---|---|
| Location | Description |
| TPSS – AP6 510 North Substation | Upgrade Protection, Control & Monitoring Capabilities |
| TPSS – AP5 4000 West Substation | Upgrade Protection, Control & Monitoring Capabilities |
| TPSS – AP4 Canal Substation | Upgrade Protection, Control & Monitoring Capabilities |
| TPSS – AP3 2100 West Substation | Upgrade Protection, Control & Monitoring Capabilities |
| TPSS – AP2 1300 West Substation | Upgrade Protection, Control & Monitoring Capabilities |
| TPSS – AP1 500 West Substation | Upgrade Protection, Control & Monitoring Capabilities |
| DS-A NO PL 400 West Street (Between North Temple and Arena) | Add Remote Monitoring to Disconnect Switches |
| DS-B NO PL 400 West Street (Between North Temple and Arena) | Add Remote Monitoring to Disconnect Switches |
| DS-1 NO (East End of Main St./400 South Interlocking) | Add Remote Monitoring to Disconnect Switches |
| DS-2 NO (East End of Main St./400 South Interlocking) | Add Remote Monitoring to Disconnect Switches |
| 3MW Jordan River Service Center Substation | Upgrade Protection, Control & Monitoring Capabilities |
| TPSS – WV6 3590 South Substation | Upgrade Protection, Control & Monitoring Capabilities |
| TPSS – WV5 3100 South Substation | Upgrade Protection, Control & Monitoring Capabilities |
| TPSS – WV4 Research Way Substation | Upgrade Protection, Control & Monitoring Capabilities |
| TPSS – WV3 Chesterfield Substation | Upgrade Protection, Control & Monitoring Capabilities |
| TPSS – WV2 900 West Substation | Upgrade Protection, Control & Monitoring Capabilities |
| TPSS – WV1 Andy Substation | Upgrade Protection, Control & Monitoring Capabilities |
| OCS1-WV-0 W Haven Ave./Union Interlocking | Add Remote Monitoring to Disconnect Switches |
| OCS2-WV-0 W Haven Ave./Union Interlocking | Add Remote Monitoring to Disconnect Switches |
| OCS2-ML-4 Union Interlocking | Upgrade Protection, Control & Monitoring Capabilities |
| TPSS – S1 Sugarhouse 1 Substation | Upgrade Protection, Control & Monitoring Capabilities |
| TPSS – S2 Sugarhouse 2 Substation | Upgrade Protection, Control & Monitoring Capabilities |
| TPSS – YRY2 Midvale Yard | Upgrade Protection, Control & Monitoring Capabilities |
| TPSS – YRY3 Midvale Yard | Upgrade Protection, Control & Monitoring Capabilities |
| TPSS – SRJ1 | Upgrade Protection, Control & Monitoring Capabilities |
| TPSS – SRJ2 | Upgrade Protection, Control & Monitoring Capabilities |
| TPSS – SRJ3 | Upgrade Protection, Control & Monitoring Capabilities |
| TPSS – SRJ4 | Upgrade Protection, Control & Monitoring Capabilities |
| TPSS – SRJ5 | Upgrade Protection, Control & Monitoring Capabilities |
| TPSS – SRJ6 | Upgrade Protection, Control & Monitoring Capabilities |
| TPSS – SRJ7 | Upgrade Protection, Control & Monitoring Capabilities |
| TPSS – SRJ8 | Upgrade Protection, Control & Monitoring Capabilities |
| TPSS -SRD15 | Upgrade Protection, Control & Monitoring Capabilities |
| TPSS -SRD16 | Upgrade Protection, Control & Monitoring Capabilities |
| TPSS -SRD17 | Upgrade Protection, Control & Monitoring Capabilities |

6 Transit Signal Priority Improvements

A focused program of transit signal priority improvements at intersections where TRAX is governed by street traffic lights is part of the Strategic Plan. These improvements will reduce (but not eliminate) the probability of light rail trains stopping at each intersection and, when they do, reduce the average waiting time. This chapter details the light rail intersection priorities for existing (2019) operations and identifies a package of 19 key intersections where UTA should work with its UDOT and Salt Lake City partners to improve transit signal priority:

- + West Valley segment of the Green Line – 9 Intersections (shown in Figure 6)
- + TRAX Trunk Line used by all three light rail lines between 900 South and the half grand union at 400 South/Main St – 5 Intersections (shown in Figure 7)
- + TRAX Trunk Line with two light rail lines – 300 South/Main St (shown in Figure 7)
- + Blue Line near Salt Lake Central – 2 Intersections (shown in Figure 7)
- + Airport segment of the Green Line – 2 Intersections (shown in Figure 7)

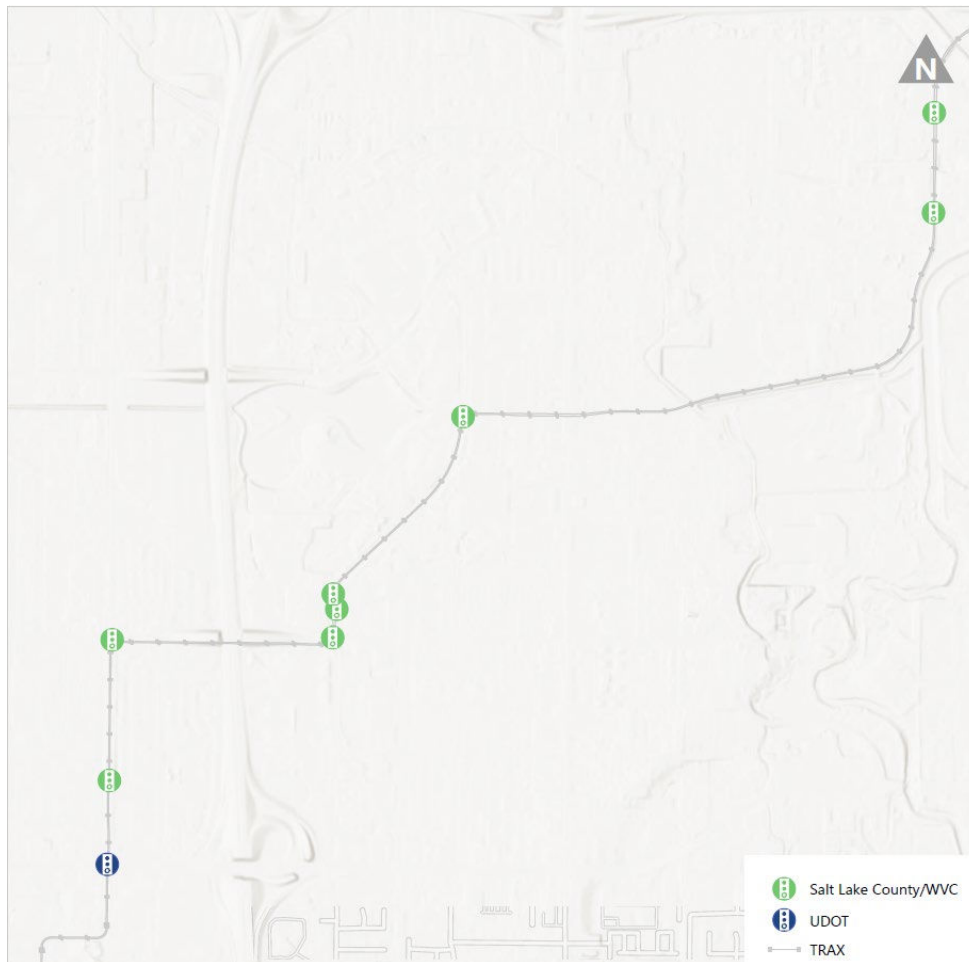

Figure 6 – Recommended West Valley Transit Signal Priority Intersection Locations

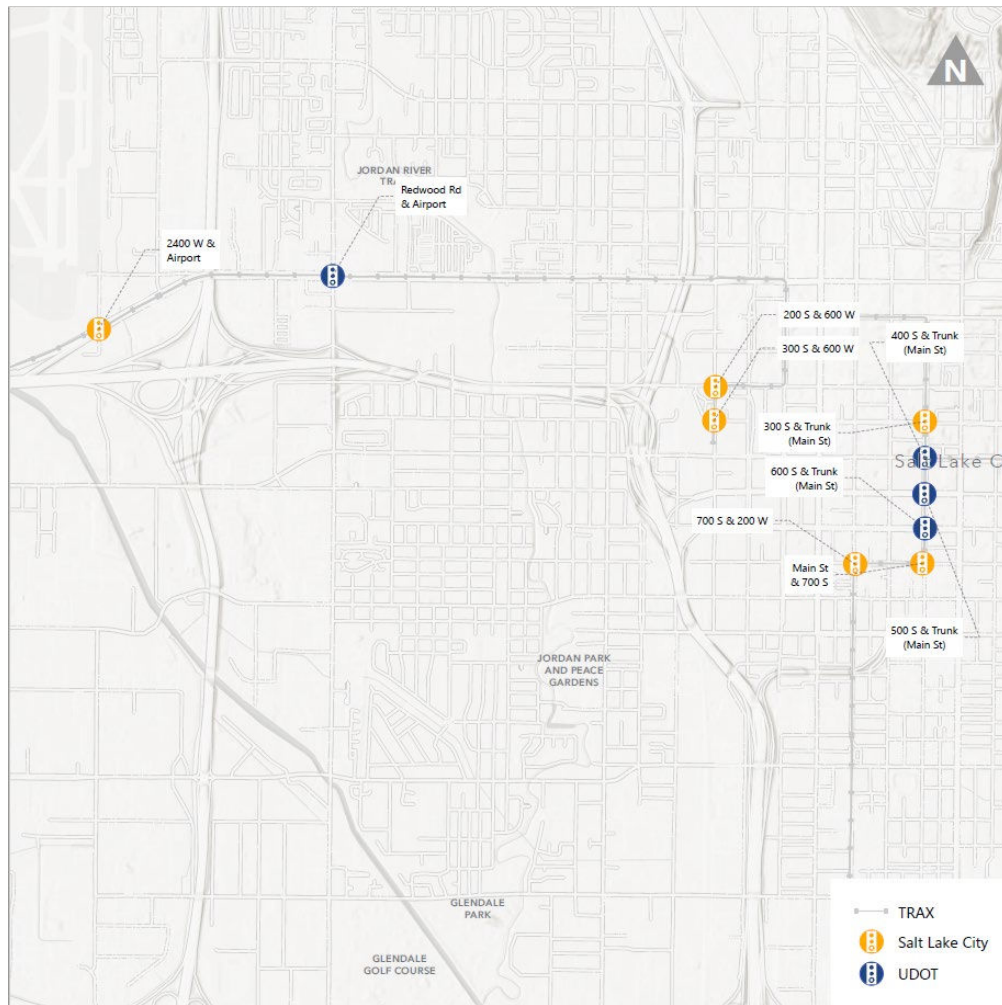

Figure 7 – Recommended Downtown and West Temple Transit Signal Priority Intersection Locations

The intersection priority data was compiled by Study team member Avenue Consultants using queries of the applicable traffic signal controllers. As such, it represents “in service” conditions. The data is organized by time of day and includes Avenue Consultants’ estimation of light rail probability of stopping at a given intersection, as well as estimated stopped time if the train does stop at the intersection. Table 14 displays only those values applicable to the morning peak period but the assessment of improved transit signal priority also addressed the evening peak period as well as off-peak periods.

The FOLR Study process started by reviewing each intersection with UTA Light Rail Operations and Service Planning personnel. They were asked to identify intersections where improved priority would provide the greatest operational benefit. The team’s traffic engineers then reviewed phasing design and event recorder data for each intersection crossed by TRAX without railroad-style gates.

Intersections with the following traffic signal controller logic types were removed from additional consideration because delays to TRAX at these locations are infrequent:

- + **Free:** Free signal operation is typically used for signals where it is not important to coordinate the arrival of vehicles between signals or where traffic volumes are lighter. When running free the signal does not have a set time that each of the phases turn green but instead serves vehicles on more of a first come first served basis.

Free operation typically benefits TRAX since there is no need to keep the signal in sync with the signals around it and priority for the TRAX line can be given more easily

- + **Preemption:** Several traffic signals use preemption in place of priority. With preemption the operations of the signal will be interrupted to allow the train to pass through the signal without stopping. Preemption is often used at more isolated traffic signals or locations where the trains are traveling at higher speeds. This type of logic has a more significant impact on the vehicle traffic at a signal than Priority logic

The following intersection traffic signal controller types were the focus of the team’s investigation of higher traffic signal priority:

- + **Coordinated:** Traffic signals that are operating with coordination are set so that vehicles traveling in the coordinated direction(s) will arrive as the light turns green. Coordination is used to predetermine when phases will turn green and will prioritize the phases associated with the main movements. While coordination does not necessarily delay TRAX, the signals that run coordination are more likely to have a heavy vehicle demand making the impacts of transit priority more severe
- + **Peer-to-Peer:** At 400 South and Main St the signal uses programmed logic to keep the signal in sync with both West Temple and State Street. While the signal is set to Free, this logic mimics a coordinated traffic signal

For these types, controller logic was reviewed to determine the maximum possible extension (“Max Extend”) of the signal phases serving the trains that the traffic signal currently allows the trains to proceed through the signal without stopping. Controller logic was also reviewed for the maximum possible time that the traffic signal currently allows the phase associated with the trains to start early (“Max Early Green”).

In the end, 19 intersections were adopted in the Strategic Plan for additional traffic signal priority. These reflect locations identified by UTA Light Rail Operations that the team’s traffic engineers found, at a planning level, had some opportunity for greater TRAX priority without materially increasing wait times for other users, including motorists, cyclists and pedestrians. Table 14 displays the current and improved TRAX stop probabilities and average wait times if a train does need to stop. The degree of improvement reflects a high level assessment by the team’s traffic engineers of each intersection’s current traffic levels and degree of congestion. As would be expected, many of the intersections are located in the more urban areas of the TRAX network:

- + Nine of the intersections are located on the West Valley segment of the Green Line
- + Five of the intersections are located on TRAX Trunk Line used by all three light rail lines between 900 South and the half grand union at 400 South/Main St with a sixth located just north of the half grand union and used by two light rail lines
- + Two of the intersections are located on the Blue Line near Salt Lake Central
- + Two of the intersections are located on the Airport segment of the Green Line

| Table 14 – Traffic Signal Priorities at Intersections Recommended for Improvement – Existing and Recommended AM Average Light Rail Stopping Probabilities and Average Waiting Times | | | | | |
|--|------------|------------------------------------|------------------------------------|------------------------------------|------------------------------------|
| Location | Dir | Existing AM Peak | | Improved AM Peak | |
| | | Light Rail Stop Probability | Average Stop Time (Seconds) | Light Rail Stop Probability | Average Stop Time (Seconds) |
| 3500 South & West Valley | NB | 66% | 38 | 50% | 29 |
| | SB | 68% | 39 | 51% | 29 |
| 3360 South & West Valley | NB | 31% | 8 | 23% | 6 |
| | SB | 31% | 8 | 23% | 6 |
| 3100 South & West Valley | NB | 63% | 28 | 47% | 21 |
| | SB | 63% | 28 | 47% | 21 |
| Decker Lake Dr & West Valley | NB | 80% | 40 | 60% | 30 |
| | SB | 80% | 40 | 60% | 30 |
| Park N Ride & West Valley | NB | 54% | 26 | 41% | 20 |
| | SB | 54% | 21 | 41% | 16 |
| Business Access & West Valley | NB | 55% | 18 | 41% | 14 |
| | SB | 55% | 18 | 41% | 14 |
| Research Way & West Valley | NB | 65% | 28 | 49% | 21 |
| | SB | 65% | 28 | 49% | 21 |
| Parkway Avenue & West Valley | NB | 20% | 5 | 15% | 4 |
| | SB | 20% | 5 | 15% | 4 |
| 2320 South & West Valley | NB | 48% | 11 | 36% | 8 |
| | SB | 48% | 11 | 36% | 8 |
| 700 South & 200 West | NB | 20% | 5 | 10% | 2.5 |
| | SB | 20% | 5 | 10% | 2.5 |
| Main St & 700 South | NB | 41% | 17 | 21% | 8.5 |
| | SB | 41% | 12 | 21% | 6 |
| 600 South & Trunk | NB | 79% | 48 | 69% | 42 |
| | SB | 54% | 33 | 47% | 29 |
| 500 South & Trunk | NB | 44% | 26 | 39% | 23 |
| | SB | 69% | 41 | 60% | 36 |
| 400 South & Trunk | NB | 60% | 14 | 45% | 11 |
| | SB | 60% | 14 | 45% | 11 |
| 300 West & Trunk | NB | 51% | 21 | 45% | 18 |
| | SB | 24% | 7 | 21% | 6 |
| 200 South & 600 West | NB | 20% | 7 | 10% | 4 |
| | SB | 20% | 7 | 10% | 4 |
| 300 South & 600 West | NB | 30% | 5 | 26% | 4 |
| | SB | 20% | 5 | 18% | 4 |
| Redwood & Airport | NB | 73% | 40 | 55% | 30 |
| | SB | 75% | 41 | 56% | 31 |
| 2400 West & Airport | NB | 75% | 34 | 66% | 30 |
| | SB | 75% | 34 | 66% | 30 |

The Study Team’s assessment of the feasibility of increasing priority for light rail trains at the intersection was based on an initial review of traffic signal settings. Many of the traffic signals were rated low due to the following factors:

- + At pedestrian crossings, an early green can often not be given since it would require prematurely ending the pedestrian phase

- + Many of the signals already allow the maximum amount of early green time available and have a substantial extended green time
- + Some intersections, such as 700 East/400 South are limited due to heavy vehicle traffic which already exceeds the intersection capacity. While heavy vehicle traffic may not preclude additional priority, it will make it difficult to avoid major impacts to the performance of the traffic signal, an outcome that the team's traffic engineers strived to avoid in their recommendations

Table 14's display of light rail stop probability reflects subtracting the estimated percent green arrival from 100%. This is an estimate of how often the train will be able to arrive at the traffic signal and pass through without stopping assuming a random arrival. The determination of this estimate was based on the green time available for the train phases at the traffic signal and the cycle length, which is the sum of the time given to all movements. The table's estimated average wait time is an estimate of the average duration of a train stop at a traffic signal before proceeding. Trains that are able to pass through the signal without stopping are not included in this average.

7 Service Improvements

The FOLR Study investigated two classes of light rail service improvements – increasing the overall hours of operation for most or all light rail services and operating additional late night/early morning light rail service to the Salt Lake City International Airport. Both improvements would enhance service during times when travel demand is typically low so these changes should be viewed in the context of regional mobility improvements rather than in the context of improving UTA efficiency or cost recovery. Both improvements are recommended for advancement as part of the Strategic Plan.

7.1 Improving TRAX Span of Service

7.1.1 Existing TRAX Start and End Time Constraints

The starting and ending times of TRAX service are currently constrained due to rail freight operations on the North/South (“Trunk”) Line and the Red Line between its junction with the North/South Line and Daybreak. This “span of service” limitation is a legacy of the legal agreements between the rail freight carriers and UTA that provided right-of-way for these TRAX segments. The presence of rail freight carriers means that these line segments are under the regulatory purview of the Federal Railroad Administration (FRA). Because the TRAX light rail vehicles are not designed to mainline railroad crash worthiness standards (and many other regulatory considerations), time-based (“temporal”) separation of rail freight and TRAX operations is required.

Span of service is important because limited operating hours may discourage both work and non-work trips on TRAX. For example, early and late shift workers include medical personnel, airport workers, warehouse, and service industry jobs. Workers on some shifts may need to be at work early (5 to 6 a.m.) while others may need to work late, with transportation home needed after 11 p.m. or midnight. Span of service is also important in terms of travel flexibility for customers making non-work trips; they want to be assured of reliable transportation home at the conclusion of an entertainment or sporting event that has a variable end time.

While not explicitly a span of service issue because of their non-revenue operation, UTA presently experiences some constraints on vehicle maintenance efficiency due to its inability to shuttle TRAX trains between Jordan River and Midvale Service Centers overnight. Some maintenance procedures, such as well truing, are only available at one facility. In addition, any proposed late night or early morning operation outside of the temporal separation area (such as between the University, Salt Lake Central and the Airport) is dependent on access to one of the two Service Centers in case of a vehicle failure, operating incident or similar occurrence where one revenue train must be swapped for another. As such, no improvement to the current span of service limitations is feasible anywhere on the TRAX network without addressing temporal separation constraints on the North/South Line.

To understand how TRAX span of service compares with similar light rail operations in the West, the Consultant Team reviewed the pre-COVID weekday operating plans of 10 light rail properties. This review, summarized in Table 15, determined:

- + Earliest system end of service time to get from any outlying station to a popular downtown station (reflecting analysis of the schedule for all stations but reporting only the earliest of these last times)
- + Earliest end of service time to get from that popular downtown station to any outlying station (reflecting analysis of the schedule for all stations but reporting only the earliest of these last times)

| Table 15 – Western United States Light Rail Span of Service Peer Review | | |
|---|--|--|
| City/Agency | Earliest System Last Time to Travel from All Outlying Stations to Downtown | Earliest System Last Time to Travel from Downtown to All Outlying Stations |
| San Jose VTA | 9:20 | 9:49 |
| San Diego MTS* | 11:18 | 10:13 |
| Sacramento RT | 9:30 | 10:19 |
| Portland TriMet MAX | 10:42 | 10:59 |
| Salt Lake City UTA* | 10:26 | 11:03 |
| Minneapolis Metro | 11:17 | 11:26 |
| Houston Metro | 11:24 | 11:53 |
| Cleveland RTA | 11:38 | 12:00 |
| Dallas DART | 11:27 | 12:08 |
| St. Louis MetroLink | 11:07 | 12:11 |
| Denver RTD | 11:11 | 12:14 |
| Los Angeles County MTA | 11:33 | 12:22 |
| Seattle Sound Transit Link | 12:00 | 12:42 |

* Light rail properties with freight temporal separation

In general, UTA’s span of service is in the middle of the peer properties surveyed. Its span of service is comparable to that of San Diego Trolley, which also has significant temporal separation operating constraints due to overnight freight operation.

7.1.2 Existing Temporal Separation Agreements with Freight Railroads

The current TRAX temporal separation constraints stem from right-of-way acquisition agreements with freight railroads for two segments of the network. The first is the TRAX North/South Line (Blue, Red and Green Lines) from 1700 South to 6400 South. Freight trains enter the alignment from Union Pacific Railroad tracks through Sampler Siding, located just south of Murray Central station at approximately 5300 South. Figure 8 shows a portion of the TRAX system map with yellow dots on the North/South Line representing current freight-related switches connecting to UTA tracks.

The second temporal freight separation segment is the TRAX Red Line from 650 West to 5600 West (Old Bingham Highway Station). Freight trains can enter the alignment from two locations – on the east through Freight Interlocking (connecting to the Savage Bingham & Garfield Railroad yard at approximately 650 West), and on the west through North Interlocking (connecting to the Garfield Branch Line at approximately 4000 West).



Figure 8 – North/South Line Active Freight Switches (Shown as Yellow Dots)

7.1.3 Analysis of Existing Freight Operations on TRAX

For the FOLR Study, UTA provided 106 days of freight dispatch data from late 2019 and early 2020. An analysis of the data found that the freight carrier, Salt Lake Southern (SLS), operated on the North/South Line on 22 of the sampled 106 days, generally Mondays and Wednesdays. Per its agreement with UTA, SLS has a five-hour operating window between midnight and 5:00 a.m. Of the 22 days of operation sampled, the actual TRAX operating windows used were:

- + Minimum North/South Line operating window used: 0:35
- + Average North/South Line operating window used: 1:54
- + Maximum North/South Line operating window used: 3:24

In contrast to the relatively light freight operation on the North/South Line, the analysis of the same 106 days of freight dispatch data indicated that the Red Line hosted 170 freight trains during this time period. This is about eight times the North/South Line volume and consisted of two freight trains per weeknight on most nights. In contrast to the gradual transition of North/South industrial properties to commercial and residential use, the Red Line freight customers are generally growing with expanded operations and increasing freight volumes. These customers include Interstate Brick, Butterfield Lumber, BMC, SME Steel, and Frito-Lay.

The Red Line also provides the only rail freight access to two freight spurs, the Bagley Spur and the Garfield Spur. In addition to SLS, the Savage, Bingham and Garfield Railroad has legal rights to operate in this area. The Garfield Spur provides access to Kennecott Copper and can have two different trains (operated by separate companies) at the same time. TRAX dispatchers, who are FRA qualified, perform these dispatching functions in addition to handling the safe movement of light rail trains.

7.1.4 Solutions for Increasing TRAX Span of Service

The FOLR Study team investigated several strategies for increasing span of service on the North/South Line used by Blue, Red and Green Line trains. The Red Line from 650 West to 5600 West (Old Bingham Highway Station) was not investigated

as freight operations are significant and no opportunities other than costly reconstruction of the light rail line (or freight line) on a separate alignment appear feasible.

For the North/South Line, one possible solution given declining freight demand would be to enter into a legally-binding agreement with all of the freight customers (active and those who are inactive but retain freight sidings) to forego future rail freight service. UTA would need to negotiate with the SLS and its corporate parent (Genesee & Wyoming) for impacts to their business. In addition, UTA would need to petition for formal abandonment of the line and obtain approval by the Surface Transportation Board. There is no assurance of such approval and UTA would continue to risk the possibility that a separate rail entity would petition to replace SLS freight service on the line. As such, this possible solution is not recommended for advancement.

Instead, a negotiated approach with the Genesee & Wyoming to reduce the freight operating window (thereby increasing the light rail operating window) is recommended for the North/South Line. This negotiation needs to be supported with a more detailed analysis of freight operations than the 106-day sample evaluated by the Consultant Team. This greater level of detail of current freight operations recorded at TRAX Central Control to support future negotiations would include:

- + Freight train time on and time off (as is done today)
- + Number of locos/number of cars
- + Industries served and duration
- + Specific routes (interlocking crossovers) used

With this data analysis in hand, several most demanding case freight operating scenarios could be developed for discussion with Genesee & Wyoming. UTA could then attempt to negotiate to reduce North/South Line freight window from the current five hours. Red, Blue and Green Line light rail service could operate later and potentially start earlier.

UTA Light Rail Operations noted that an increase in TRAX span of service may impact maintenance efficiencies in non-temporally separated segments of the light rail network. In other words, UTA takes advantage of the freight operating window's preclusion of light rail train movements in other segments of the system to perform maintenance. Some activities, such as tie replacement, require significant mobilization time and cannot be performed efficiently in a short time window.

It may also be possible to negotiate a reduction in temporal separation to three early mornings per week – Mondays, Wednesdays, Fridays. This would not have a direct span of service benefit to UTA customers but would open North/South Line windows on Tuesday and Thursday early mornings for predictable additional maintenance windows. It would also allow for more flexible light rail vehicle shuttling between Midvale and Jordan River Service Centers.

Separately, UTA could pursue abandonment of freight service north of 2200 South which would eliminate any span of service constraints on Green Line operation (and potential future Orange Line operation). At present, there is only one in-service freight switch, serving Intermountain Wood Products, in this TRAX segment. This freight customer, should it wish to continue receiving or shipping freight by rail, could use the public "Team Track" siding near 3300 South (while expecting some compensation from UTA for this loss of shipping convenience). With such a change, UTA would have the flexibility to operate 24-hour service overnight on the Green Line. Such service has been considered in the past on the Airport Line segment but was deemed to have required a satellite rail vehicle maintenance facility. With abandonment of freight service north of 2200 South, the full Green Line would have access to the Jordan River Service Center at all times, eliminating the need for a satellite maintenance facility.

7.2 Airport Line Extended Hours Travel Demand Analysis

Extended hours of service, including to the Salt Lake City International Airport, is one of the recommended components of the Strategic Plan. As part of the project, several short-term service options were considered and assessed in conjunction with a review of how other transit systems serve other airports across the county. Salt Lake City International Airport worker schedules and home locations were also analyzed to understand the potential market for extended hours of service.

Currently, UTA operates service to and from the airport between approximately 6 a.m. and 11:30 p.m. As shown in Table 16, this level of service is like many other locations across the country, even in locations where annual enplanements are higher than at Salt Lake City International Airport. Only two transit agencies provide all-night service to airports; New York (John F. Kennedy International Airport) and Chicago (O’Hare). However, several other agencies provide later night service and/or provide earlier morning service. For example, agencies in Chicago (Midway Airport), Denver, Dallas, Newark, Portland, and Cleveland all provide service to their respective airport before 5 a.m. and in some cases as early as approximately 3:30 a.m. Many also provide service later, with final trips from the airport occurring after 1 a.m. While this type of service provides accessibility to airport users, it is more likely that these services are focused on supporting airport worker swing shifts.

| Metro Area | Airport | Mode | First Weekday Arr | Last Weekday Dep | 2021 Enplanements |
|----------------|---------|---------------|-------------------|------------------|-------------------|
| Atlanta | ATL | Heavy rail | 5:24 a.m. | 1:00 a.m. | 36,676,010 |
| Dallas | DFW | Light rail | 3:50 a.m. | 1:11 a.m. | 30,005,266 |
| Denver | DIA | Commuter rail | 3:37 a.m. | 1:27 a.m. | 28,645,527 |
| Chicago | ORD | Heavy rail | All night service | | 26,350,976 |
| Miami | MIA | Heavy rail | 5:05 a.m. | 12:20 a.m. | 17,500,096 |
| Seattle | SEA | Light rail | 5:35 a.m. | 11:44 p.m. | 17,430,195 |
| New York | JFK | Heavy rail | All night service | | 15,273,342 |
| Newark | EWR | Commuter rail | 4:41 a.m. | 2:19 a.m. | 14,514,049 |
| San Francisco | SFO | Heavy rail | 5:59 a.m. | 11:59 p.m. | 11,725,347 |
| Salt Lake City | SLC | Light rail | 5:55 a.m. | 11:23 p.m. | 10,795,906 |
| Philadelphia | PHL | Commuter rail | 5:22 a.m. | 12:07 a.m. | 9,809,968 |
| Baltimore | BWI | Light rail | 5:35 a.m. | 11:10 p.m. | 9,253,561 |
| Chicago | MDW | Heavy Rail | 4:24 a.m. | 1:05 a.m. | 7,680,617 |
| Washington, DC | DCA | Heavy rail | 5:59 a.m. | 11:32 p.m. | 6,731,737 |
| Portland | PDX | Light rail | 4:50 a.m. | 12:30 a.m. | 5,759,879 |
| San Jose | SJC | Light rail | 5:48 a.m. | 12:06 a.m. | 3,619,690 |
| Cleveland | CLE | Heavy rail | 3:39 a.m. | 1:22 a.m. | 3,552,402 |

Table 16, shows airport rail service where daytime frequencies are 30 minutes or better. There are other airport rail services, generally operated by commuter rail, which provide regularly scheduled service but less frequently than once every 30 minutes. Table 16 also excludes airport rail service that requires a shuttle bus connection such as at Los Angeles International (LAX) and Boston Logan (BOS).

Survey data provided by UTA and obtained from the Salt Lake International Airport suggests that many airport workers in Salt Lake City have shift times incompatible with the current service hours, as shown in Figure 9. Approximately 58% of employees from the survey have shifts that either begin or end outside of the current Green Line service hours. The shift time with the highest number of responses was 5 a.m. to 1 pm. This suggests that even extending service to provide trips to the airport slightly earlier in the morning would better match a large share of airport worker shift times.

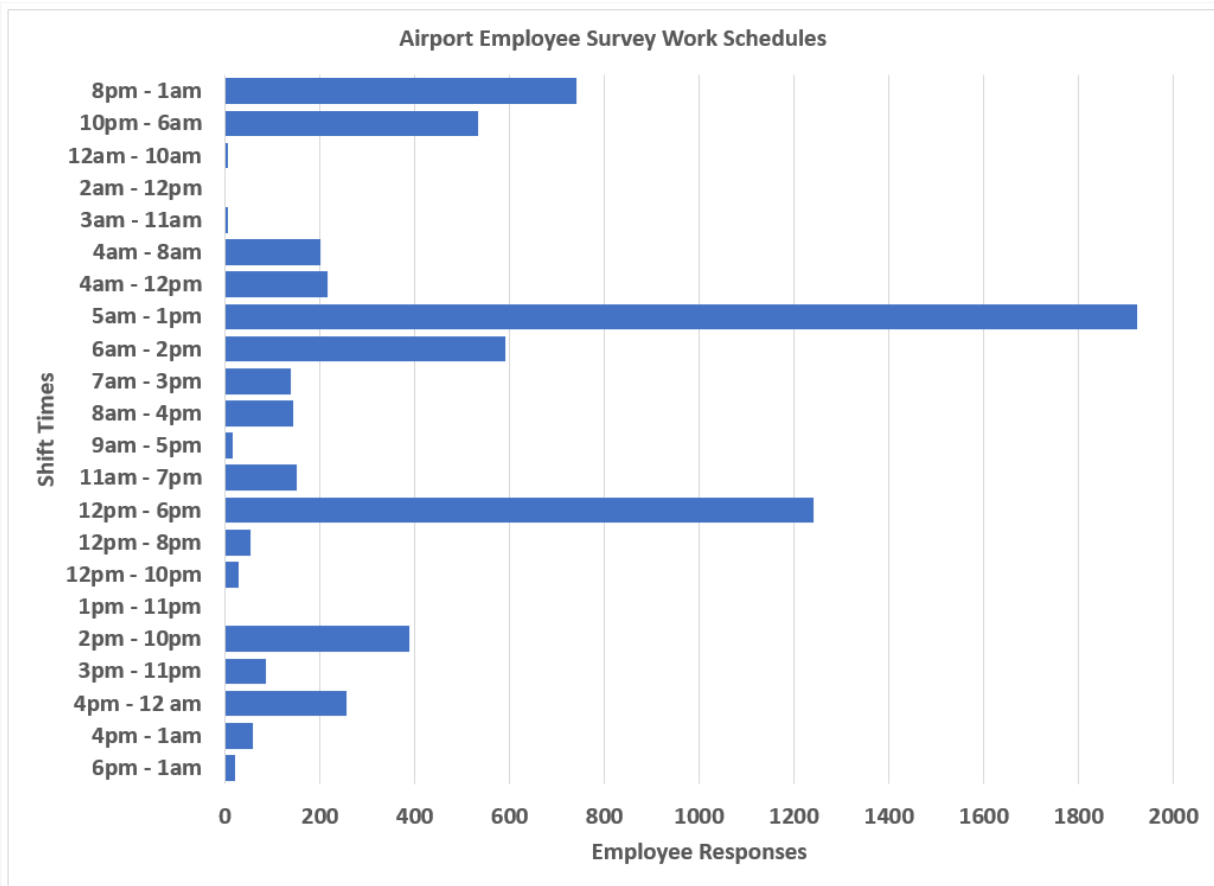

Figure 9 –Airport Employee Survey Work Schedules

Two short-term extended service options were considered. The first would expand the Green Line hours of service but provide lower frequency than is offered during the daytime during these extended hours, between 30 and 60-minute headways. This would serve a total of 19 stations, three of which have park-and-ride facilities (West Valley Central, Central Pointe, and Ballpark). This service would operate through approximately 23 equity focused areas identified by the Wasatch Front Regional Council (WFRC). To operate, this would require enhanced freight separation for access to the Jordan River Rail Service Center and single-track revenue operation between the Union and Ballpark Interlockings surrounding Central Pointe.

The second option would create a new late night/early morning service designated the Orange Line that would only operate during the expanded hours. As with the first option, this service would have lower frequency headways than daytime operation of between 30 and 60 minutes, but the route would operate between the University Medical Center (or Research Park in the future, once such an extension is in service) and the Airport. This would serve 17 stations but would not serve any existing UTA owned park-and-ride locations. It would serve 18 Equity Focus Areas. To operate, this would require enhanced freight separation but only for access to the Service Center in case of vehicle maintenance issues.

The second option would also serve late-night travel between downtown and the University, including University employees with early morning shift starts. The second option represents an unusual service offering in that the Orange Line would operate only during the late night/early morning hours. Such service could result in confusion to occasional riders as it would not be offered during most of UTA’s operating hours.

To better assess how these two options might serve airport swing shift workers, UTA provided home zip code data for 14,000 badged employees. These were mapped using GIS to assess which option might serve a larger share of airport

workers. As shown in Figure 10, there is high concentration of airport workers both adjacent to the airport and along the Green Line out to West Valley City. There are also concentrations further west and south. While there are some airport works to the east, the concentration is much lower, particularly between downtown and the University of Utah.

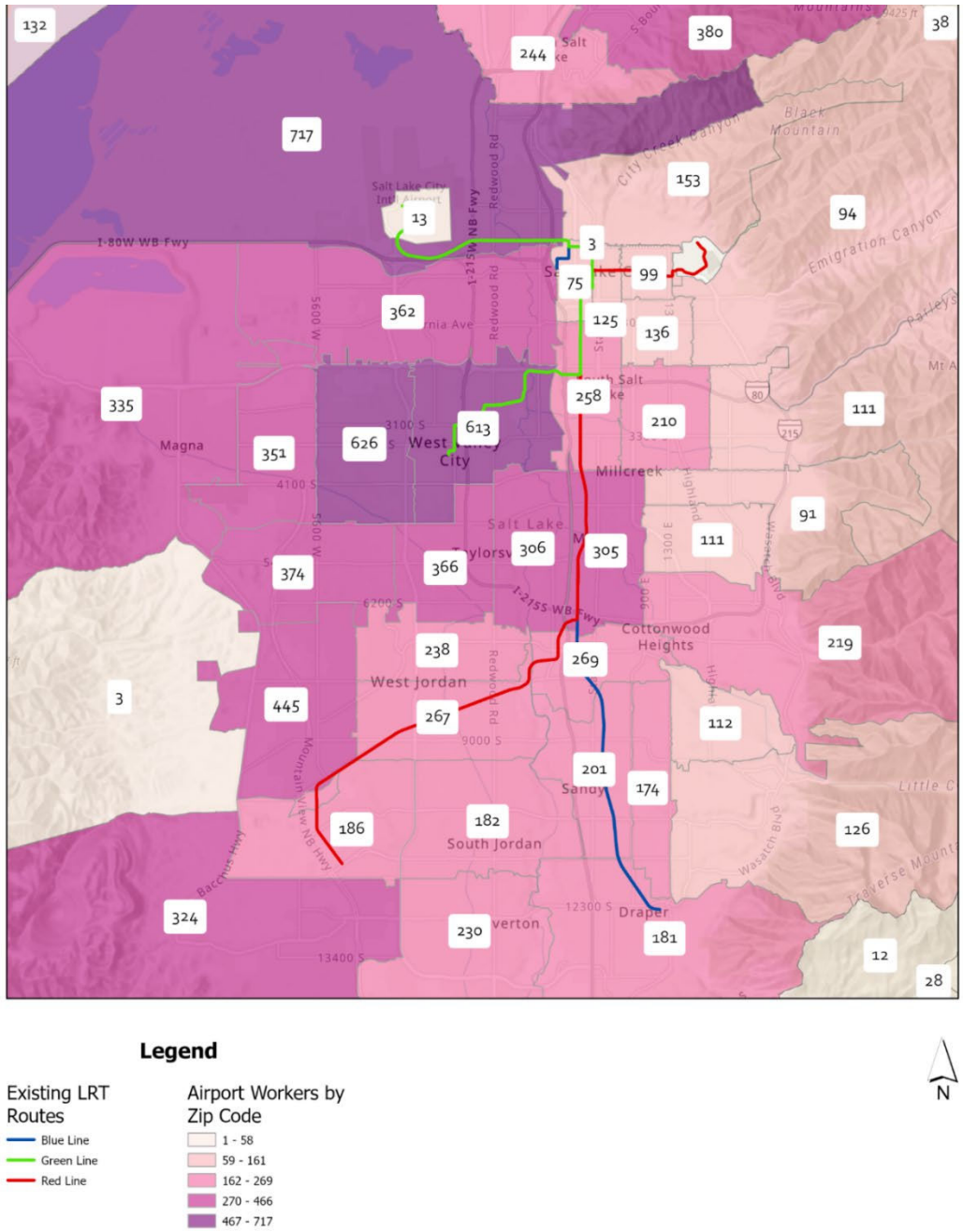

Figure 10 – Airport Worker Residences by Zip Code

Based on this mapping, the Green Line service option would provide access to more airport workers. However, it should be noted that late night service would support late-shift workers at other employment centers as well. The second option may not provide access to a large share of airport workers but may serve other late-shift workers along the 400 South corridor.

This type of service is likely to have limited ridership no matter the option implemented. Available ridership by time of day from other agencies that provide late night/early morning service was reviewed, although the sample was very limited. While data from Denver suggests that there are trips to the airport that carry up to 100 passengers on two-car commuter rail trains during late night/early morning service, data from New Jersey Transit shows much lower ridership during late night/early morning service to the airport, with some trips carrying only a few passengers. New Jersey Transit service to Newark Airport requires connection to a monorail service that connects the rail station to the three airport terminals, reducing the attractiveness of the service versus other modes that can access the terminals directly. Salt Lake City is smaller than both these areas in both population and enplanements. Additionally, airport parking costs are relatively low and the short distance between the airport and downtown Salt Lake City makes utilization of Transportation Network Companies (TNCs) like Uber and Lyft a relatively low-cost alternative. Therefore, the market for late night/early morning rail service to the airport is likely to be limited beyond employees.

It should be noted that offering late night and early morning service, while likely to have limited ridership impact, would help to address transportation equity. A recent American Public Transit Association (APTA) report notes that the annual median wage for late-shift workers is 14% lower than the median wage for daytime employees and African American and Latinos are more likely than the overall workforce to arrive at work in the evening, late-night, and early-morning hours⁹. Providing transit service for these workers would help to provide a viable alternative to a personal vehicle and potentially help to reduce transportation costs.

While expanded service is part of the Strategic Plan Span of Service Elements, it requires further study to determine routing and demand for such a service as well as assess the return on investment. A future study should also consider how the service supports regional equity and economic development goals.

⁹ *Supporting Late-Shift Workers: Their Transportation Needs and the Economy*, American Public Transportation Association, 2019.

8 Potential Strategic Plan Improvements Funding Sources and Implementation Plan

This chapter summarizes the required regional investment needed to implement the Light Rail Strategic Plan over the coming two decades as well as potential funding sources for this investment. The figures cited herein do not include on-going operating and maintenance costs of the light rail network.

8.1 Strategic Plan Capital Cost Estimate

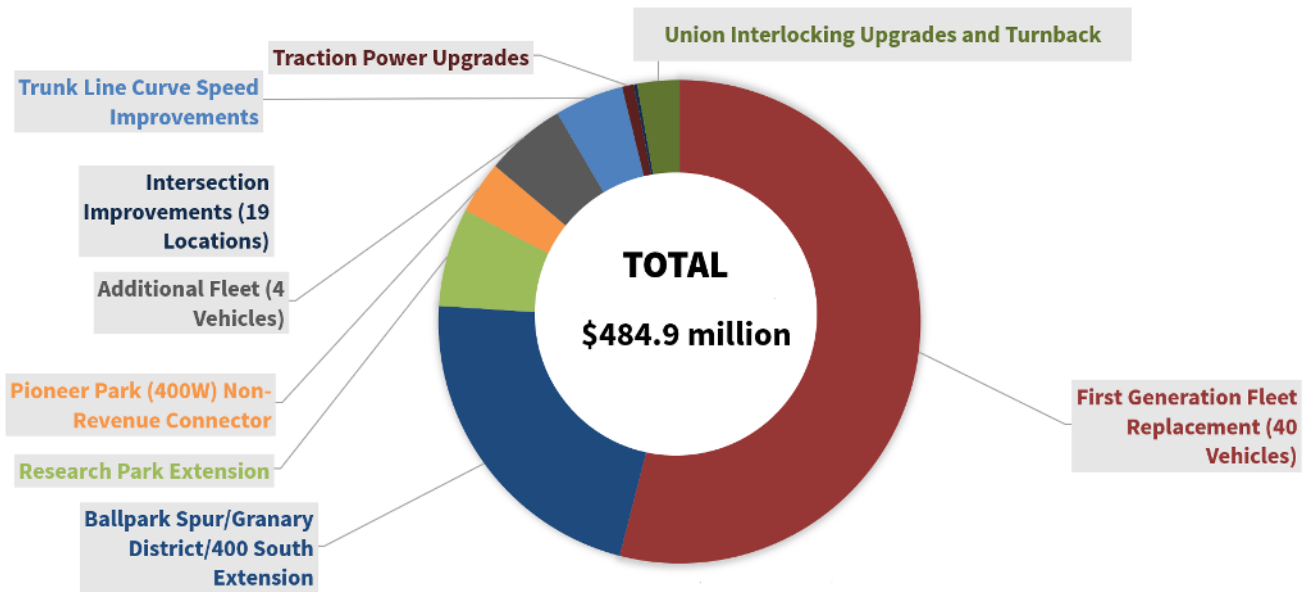

Figure 11 –Strategic Plan Estimated Capital Cost (2022 Dollars)

Figure 11 provides a graphical representation of the recommended \$484.9 million Strategic Plan budget. These capital costs, developed largely by the FOLR Study team, include construction costs, real estate acquisition costs (where identified by conceptual plans), 30% allocated contingency and an additional 30% unallocated contingency applied to all costs. Costs are shown in 2022 dollars and have not been escalated to a potential midpoint of construction.

The First Generation Fleet Replacement cost was developed by UTA; the Study team’s independent planning level cost estimate yielded a similar figure. The traction power upgrade cost was developed by the UTA and is subject to change.

Specific Strategic Plan capital costs that comprise the total \$484.9 million capital cost include:

- + First Generation Fleet Replacement (40 Vehicles): \$250 million
- + Ballpark Spur/Granary District/400 South Extension: \$123.9 million
- + Research Park Extension: \$30.4 million
- + Pioneer Park (400W) Non-Revenue Connector: \$16.4 million
- + Additional Fleet (4 Vehicles): \$25 million
- + Trunk Line Curve Speed Improvements: \$21.4 million
- + Traction Power Upgrades: \$3.7 million

- + Intersection Improvements (19 Locations): \$1 million
- + Union Interlocking Upgrades and Turnback: \$13.1 million

Real estate acquisition costs for the Research Park Extension were not included as a precise alignment has not yet been defined in the University’s Strategic Vision Plan. The extension’s off-street alignment may use University property. The first generation fleet replacement does not include removal of the station “high blocks” needed for level boarding of the first generation fleet but no longer needed with a new partial or full low floor fleet. These high blocks exist at all stations served by the Blue Line as well as at select other TRAX stations. Removal of the “high blocks” is not required for operation of an all-low-floor fleet but should be pursued as an on-going UTA State of Good Repair activity to eliminate on-going maintenance requirements.

8.2 Regional Transportation Plan Updating

The Wasatch Front Regional Council (WFRC) and Mountainland Association of Governments (MAG) are the MPOs in the UTA service area. They develop Regional Transportation Plans (RTPs) for the region and are also key partners in implementing transit infrastructure through partnerships and funding.

While the current TRAX system falls entirely within the WFRC area, the two MPOs, in coordination with UTA, jointly determine regional transit needs and reasonable financial assumptions for RTP development. The MPOs have played a significant role in the development of UTA transit investments, including the development and implementation of the initial TRAX system and all subsequent extensions. To implement the Light Rail Strategic Plan, the MPOs need to identify the components of the plan as a regional need, incorporate these components into the RTPs in funded phases, and partner with UTA to secure political and public support and funding for implementation.

The RTPs include some UTA light rail and streetcar projects evaluated during the FOLR Study but that were not included in the Strategic Plan due to lack of stakeholder and/or TAC support. In many cases, a related project that provided similar benefits but using a different concept alignment or service pattern was included instead. UTA will need to work with the MPOs to determine whether some of these light rail and streetcar projects should be removed or modified in the RTPs.

| Table 17 – Regional Transportation Plan Financial Inputs from Light Strategic Plan | | | | |
|--|--------------------------------|------------------|---------------------------------|------------------|
| | Capital Cost (2022 Dollars) | Incremental Cost | TRAX O&M Cost (2022 Dollars) | Incremental Cost |
| Future Baseline | N.A. | N.A. | \$68.4 million | N.A. |
| RTP Phase 2 (2031-2040) | \$459.9 million | \$459.9 million | \$78.7 million | \$10.4 million |
| RTP Phase 3 (2041-2050) | \$484.9 million | \$25.0 million | \$86.2 million | \$7.5 million |

Table 17 summarizes the WFRC RTP inputs related to the Light Rail Strategic Plan. All of the Strategic Plan capital and service improvements are recommended for implementation by 2040, coinciding with RTP Phase 2, except for extension of the new Orange Line from Salt Lake Central to the Airport. The Orange Line extension falls into RTP Phase 3, which extends through 2050. As such, all of the Light Rail Strategic Plan capital costs are assigned to RTP Phase 2, except for the four additional LRVs needed to support Orange Line service from Salt Lake Central to the Airport. This \$25 million capital cost is assigned to RTP Phase 3 in Table 17.

In terms of O&M costs, Table 17 shows the Future Baseline annual operating costs for the three TRAX light rail lines and S-Line streetcar at \$68.4 million (in 2022 dollars). This reflects today’s UTA operating budget for the Light Rail Business Unit, including allocation of UTA overhead. With the Strategic Plan service realignments (Red Line via the Granary) and additions (new Orange Line from Research Park to Salt Lake Central), annual operating costs increase by \$10.4 million. In RTP Phase 3, annual operating costs increase an additional \$7.5 million as the Orange Line is

extended from Salt Lake Central to the Airport. Refer to Appendix C for more information on how the future O&M costs were estimated.

8.3 Potential Funding Sources

UTA has a successful record in assembling federal, state and local funding to implement transit projects in the region. State and local funding generally is generally the most straight-forward source of funding given that it generally does not come with significant grant requirements such as “Buy America” and prevailing wage rate requirements. The federal Davis-Bacon and Related Acts, administered by the U.S. Department of Labor, apply to contractors and subcontractors performing on federally funded or assisted contracts in excess of \$2,000 for the construction, alteration, or repair of public buildings or public works. Davis-Bacon Act and Related Act contractors and subcontractors must pay their laborers and mechanics employed under the contract no less than the locally prevailing wages and fringe benefits for corresponding work on similar projects in the area.

Despite significant grant requirements and constraints, federal funding through competitive FTA programs can provide another opportunity for implementation of Strategic Plan elements. FTA programs change periodically, responding to programmatic priorities of the White House and Congress. FTA programs almost always require a local match, and this percentage of the project can be significant (approaching 50%). This can obviously make federal funding less appealing than a pure local/state approach, especially given that federal funding requirements can sometimes increase project costs due to “Buy America”, prevailing wage rules and other requirements. Grant applications are almost always highly competitive; funding for new lines and line extensions requires that the project reflect a locally-preferred alternative and that the project be environmentally cleared.

Current USDOT and FTA programs relevant to specific Strategic Plan elements include:

- + USDOT Rebuilding American Infrastructure with Sustainability and Equity (RAISE) Grants
- + USDOT Surface Transportation Block Grants, part of the FAST Act
- + FTA Capital Investment Grants (Section 5309)
- + FTA Grant Program for Rail Vehicle Replacement

In addition, the emerging area of Value Capture Strategies offers promise for incremental funding of some projects, such as the Granary District and Research Park extensions. These strategies rarely cover all project costs but may support UTA in covering the local match requirement of an FTA program grant. Tax Increment Financing is one form of Value Capture that takes advantage of increased real estate valuations where transit (especially dedicated guideway transit) is being constructed. A local Tax Assessment District is created with a special property tax assessment that reflects enhanced real estate values. The recurring income stream from such incremental taxation can be monetized in the form of long-term bonds issued by the Tax Assessment District or underlying municipality (Salt Lake City in both of these Strategic Plan projects). The proceeds of the long-term bond sale can be used to support project construction costs.

Another Value Capture Strategy is the use of public/private partnerships to fund station improvements. While private real estate developers rarely find the value of new fixed guideway transit serving their properties sufficient to fund all of the project costs, they may be willing to fund new stations such as those proposed at Research Park and in the Granary. The sponsoring agency, in turn, may be willing to make certain concessions such as facilitating convenient pedestrian connections between the station and the real estate development and/or granting station “naming rights” to developers/major businesses.

Philadelphia’s SEPTA has completed five such “naming rights” agreements over the last 10 years with the latest being the new “Wawa Station” (named after a convenience store chain) that opened in August, 2022. Wawa is paying \$5.4 million in naming rights under a 10-year contract. Other SEPTA naming rights agreements include the AT&T

Station at the Sports Complex terminus of the Broad Street line. In addition, the former Market East station is now Jefferson Station (named after a local hospital) and the former University City Regional Rail station in West Philadelphia is now the Penn Medicine Station.

8.4 Next Steps

Table 18 summarizes the Strategic Plan elements, suggested UTA next steps to advance each initiative and potential implementation time frames. These time frames, of course, depend on the ability to modify the RTPs, the ability to secure funding and continued travel demand recovery as the region, nation and world emerge from the effects of the COVID-19 pandemic.

Before any service changes are advanced, UTA must perform a comprehensive U.S. Title VI equity and environmental justice analysis.

| Table 18 – Recommended UTA Actions to Advance Strategic Plan Improvements and Possible Implementation Timeframes | | |
|---|--|--|
| Strategic Plan Element | UTA Early Actions | Possible Implementation Timeframe |
| Intersection Transit Priority Improvements | Engage Salt Lake City, UDOT | 2023-24 |
| Trunk Line Speed Improvements | Initiate Design | 2024-26 |
| Start Service Earlier, End Later | Initiate Freight Rail Negotiations | 2026-27 |
| Operate Late Night/Early Morning Airport Service | Requires Further Demand Study and Analysis of Regional ROI | 2026-27 |
| Service Reliability Improvements – Union Turnback | Initiate Design | 2027-28 |
| Replace First Generation Fleet | Complete Specification, RFP | 2027-30 |
| Research Park TRAX Extension | Proceed with TechLink Study, Refine Concepts, Station Locations, Service Strategy, Funding | 2030-34 |
| Granary District TRAX Expansion | | 2035-45 |
| Service Reliability Improvements – 400W Connector | | 2035-45 |
| Intersection Transit Priority Improvements | Engage Salt Lake City, UDOT | 2023-24 |
| Trunk Line Speed Improvements | Initiate Design | 2024-26 |

9 Strategic Plan Scenarios Development

Both phases of the Study included development of FOLR scenarios. Phase 1 started with a baseline scenario, followed by a Future Baseline Scenario, with the intention of being used as a baseline against which to compare the analytical results of the Strategic Plan improvements. These results took the form of travel demand model results, operations & maintenance costs and network operations simulation modeling that produced results of travel times, service reliability (on-time performance) and service delivery . The Future Baseline added the new 600 South Station and relocated Airport Station, neither of which were in service in 2019 but both of which have now been completed.

Phase 1 of the Study also tested six “build” scenarios:

- + Phase 1 Scenario 1: Intersection Priority Improvements
- + Phase 1 Scenario 2: Trunk Line Curve Speed Improvements
- + Phase 1 Scenario 3: Additional Intersection Priority Improvements
- + Phase 1 Scenario 4: Granary District/West Downtown Network Improvements with New Orange Line
- + Phase 1 Scenario 5: Research Park Extension
- + Phase 1 Scenario 6: Existing Network with 12-Minute Branch Headways

With the results of these six scenarios in hand, a daylong workshop was held to craft the Phase 2 scenarios. Unlike Phase 1, the Phase 2 scenarios blended multiple service initiatives and capital investments, focusing variously on span of service, frequency of service and serving new markets.

The in-person workshop included TAC and other stakeholder representatives from multiple UTA departments, UDOT, the MPOs and many municipalities served by TRAX (or potentially served by TRAX in the future):

- + Murray
- + Salt Lake City
- + Salt Lake County
- + Sandy
- + South Salt Lake City
- + UDOT
- + University of Utah
- + UTA Community Engagement
- + UTA Customer Communications
- + UTA Environmental & Grant Services
- + UTA Light Rail Service
- + UTA Light Rail Vehicle Maintenance
- + UTA Planning
- + UTA Public Relations and Marketing
- + UTA Service Planning
- + UTA Transit Oriented Development
- + Wasatch Front Regional Council

- + West Jordan
- + West Valley City

Refer to Appendix J for a full list of FOLR Study TAC members’ titles and organizations.

The workshop started with a brief overview of the FOLR Study and its goals, noting that the workshop represents the start of the second phase of the Study. Many of the workshop participants attended the virtual TAC meetings during the first phase of the Study. For the first activity in the workshop, participants were seated at assigned tables, with table-specific professional backgrounds such as engineering, planning and UTA operations, with some exceptions.

The goals of the workshop were then detailed, with the purpose described as to both identify the highest priority regional benefits of TRAX improvements and to create four contrasting scenarios that work towards achieving the four highest-ranked benefits priorities. Eight benefit categories were identified by UTA and the Study team and shown in Table 19 below, referring participants to the informational packets on each table.

The distinctions between benefits such as Economic Development, More Access to Jobs Services & Housing, and Serves New Markets benefits were discussed by the group. The group concluded that there is significant overlap across these three benefits categories. In addition, most groups also felt there was overlap between Improved Frequency and Improved Travel Time, both of which ended up as shared high priorities among groups.

Each group reported out at the conclusion of Activity 1; Table 19 shows the ranked order of each group’s top four benefits selections with the table containing a placeholder value of 5 where a given benefit was not selected by a group. The most desirable benefits are represented by the lowest scores in the table and are also highlighted in yellow.

| Table 19 – Activity 1 – Benefits Focus of Scenarios (Lowest Score Most Important) | | | | | |
|--|----------------|----------------|----------------|----------------|--------------|
| | Group 1 | Group 2 | Group 3 | Group 4 | Total |
| Economic Development | 4 | 5 | 5 | 5 | 19 |
| Improved Frequency | 5 | 1 | 1 | 2 | 9 |
| Improved Travel Time | 2 | 2 | 2 | 3 | 9 |
| More Access to Jobs, Services & Housing | 1 | 3 | 3 | 1 | 8 |
| Greater Service Span | 3 | 5 | 4 | 4 | 16 |
| Improved Reliability | 5 | 4 | 5 | 5 | 19 |
| Increased Efficiency | 5 | 5 | 5 | 5 | 20 |
| Serves New Markets | 5 | 5 | 5 | 5 | 20 |

For Activity 2, the workshop participants formed new groups that intended to have a mix of professional backgrounds and were assigned one of the selected benefit categories from Activity 1 to focus on. The Study team presented the specific improvements identified and analyzed at a concept level in Phase 1 of the FOLR Study and shown in Table 20 below. Each table was instructed to develop a future light rail scenario that achieved the benefits assigned to their table, and the Study team suggested that secondary benefits should be considered as well. The Study team noted that each improvement has a dollar sign cost value and that the groups should stick to a budget of no more than 15 dollars. During the course of the exercise, it was determined that it would be beneficial in the analysis if the groups could prioritize their “purchases” in descending order in case the budget had been lower.

The workshop results were extremely helpful to the Study team. It was noted at the workshop that the scenarios will be further defined and then analyzed in terms of ridership, operability, community/environmental impact, capital cost, operating cost and other metrics.

Table 20 – Activity 2 – All Selected Improvements Shown in Ranked Order

| | Scenario 1 – New Group 1 (Improved Frequency) | Scenario 2 – New Group 2 (Span of Service) | Scenario 3 – New Group 3 (More Access) | Scenario 4 – New Group 4 (Improved Travel Time) |
|--|--|---|---|--|
| CAP-1 Trunk Line Curve Speed Improvements | | 3 | | 1 |
| SVC-1 All-night Green Line Service to Airport | 6 | 2 | 2 | 6 |
| SVC-2 Granary District Along 400 West to 900 South | | 1 | 3 | 5 |
| SVC-3 Improve Branch Headways from 15 Minutes to 12 Minutes | 2 | | 6 | |
| SVC-4 New Direct Service, University to Salt Lake Central | 3 | 4 | 5 | |
| SVC-5 New Direct Service, University to Salt Lake City International Airport | 3 | 5 | 7 | |
| INT-1 Intersection Priorities – Modest Improvements | | | 8 | |
| INT-2 Intersection Priorities – Medium Improvements | | 6 | | |
| INT-3 Intersection Priorities – Extensive Improvements | 5 | | | 2 |
| EXT-1 Connection to Depot / Salt Lake Central | | | | |
| EXT-2 Granary District Along 400 West to 900 South | 1 | 7 | 4 | 4 |
| EXT-3 Millcreek Streetcar / “Local Link” | | | | |
| EXT-4 Red Line Connection – 1100 East to 900 East Station | | | | |
| EXT-5 Downtown-University Streetcar – on 100 or 200 South | | | | 3 |
| EXT-6 Extension to Research Park from South Campus Drive | 4 | 8 | 1 | 7 |

Subsequent to the workshop, the Study team elected to remove some of the lower priority improvements in order to reduce the anticipated capital and operating costs of scenarios and to provide greater contrasts among the scenarios. All of the “6”, “7” and “8” scores (the lowest-ranking scores across the scenarios) were removed with the exception of the Medium Priority Intersection Priorities for Group 2 and the Improved Branch Headways in Group 3. The changes are shown in red text in Table 21, where red indicates deletion.

Table 21 – Activity 2 – All Selected Improvements Shown in Ranked Order (As Revised, Red Indicating Removed)

| | Scenario 1 – New Group 1 (Improved Frequency) | Scenario 2 – New Group 2 (Span of Service) | Scenario 3 – New Group 3 (More Access) | Scenario 4 – New Group 4 (Improved Travel Time) |
|---|--|---|---|--|
| CAP-1 Trunk Line Curve Speed Improvements | | 3 | | 1 |
| SVC-1 All-night Green Line Service to Airport | 6 | 2 | 2 | 6 |
| SVC-2 Granary District Along 400 West to 900 South | | 1 | 3 | 5 |
| SVC-3 Improve Branch Headways from 15 Minutes to 12 Minutes | 2 | | 6 | |
| SVC-4 New Direct Service, University to Salt Lake Central | 3 | 4 | 5 | |

Table 21 – Activity 2 – All Selected Improvements Shown in Ranked Order (As Revised, Red Indicating Removed)

| | Scenario 1 – New Group 1 (Improved Frequency) | Scenario 2 – New Group 2 (Span of Service) | Scenario 3 – New Group 3 (More Access) | Scenario 4 – New Group 4 (Improved Travel Time) |
|--|--|---|---|--|
| SVC-5 New Direct Service, University to Salt Lake City International Airport | 3 | 5 | 7 | |
| INT-1 Intersection Priorities – Modest Improvements | | | 8 | |
| INT-2 Intersection Priorities – Medium Improvements | | 6 | | |
| INT-3 Intersection Priorities – Extensive Improvements | 5 | | | 2 |
| EXT-1 Connection to Depot / Salt Lake Central | | | | |
| EXT-2 Granary District Along 400 West to 900 South | 1 | 7 | 4 | 4 |
| EXT-3 Millcreek Streetcar / “Local Link” | | | | |
| EXT-4 Red Line Connection – 1100 East to 900 East Station | | | | |
| EXT-5 Downtown-University Streetcar – on 100 or 200 South | | | | 3 |
| EXT-6 Extension to Research Park from South Campus Drive | 4 | 8 | 1 | 7 |

The resultant scenarios are summarized in Figure 12 to Figure 15. Figure 12 shows the Improved Frequency Scenario, Figure 13 shows the Improved Span of Service Scenario, Figure 14 shows the Greater Access Scenario and Figure 15 shows the Improved Travel Time Scenario. Commuter rail (purple line) is shown on the schematics for context and consistent for all scenarios but not counted in the scenario characteristics. The results of these four Phase 2 scenarios in terms of travel demand, access to jobs and other opportunities, annual O&M costs and operations simulations (travel time, reliability, service delivery) were then used to inform the recommended Strategic Plan scenario.

Table 22 – Future of Light Rail Scenario Attributes

| | Scenario 1 – Improved Frequency | Scenario 2 – Improved Span of Service | Scenario 3 – More Access | Scenario 4 – Improved Travel Time |
|---------------------------------------|--|---|--|--|
| Number of Light Rail Services | 4 | 4 | 4 | 3 |
| Number of Streetcar Services | 1 | 1 | 1 | 2 |
| Number of Main St Services | 2 | 2 | 2 | 1 |
| Span of Service | Existing | All Night (West Valley, Airport) | All Night (West Valley, Airport, University) | Earlier/Later Service |
| Frequency of Service | Improved | Existing | Improved | Existing |
| Trunk Line Speed Improvements | | • | | • |
| Main Street/400 South Operations | 2 Turning, 1 Straight Service | 1 Turning, 2 Straight Crossing 1 Straight Service | 2 Straight Crossing 2 Straight Services | 1 Turning, 1 Straight Service |
| Salt Lake Central Station Operations | Terminus Only | Interleaved Terminus and Run-through | Run-through (Interlined) Only | Terminus Only |
| Direct Service, SLC to University | | • (Light Rail) | • (Light Rail) | • (Streetcar) |
| Direct Service, Airport to University | • | • | | |
| Direct Service, Airport to Downtown | • | • | • | |
| Direct Service, Airport to SLC | | • | | |
| Direct Service, Airport to Granary | | • | | • |

Table 22 – Future of Light Rail Scenario Attributes

| | Scenario 1 – Improved Frequency | Scenario 2 – Improved Span of Service | Scenario 3 – More Access | Scenario 4 – Improved Travel Time |
|---|--|--|---------------------------------|--|
| Intersection Priorities | Extensive Improvements | Medium Improvements | Existing | Extensive Improvements |
| 400 South Extension | | • | • | |
| Ballpark Spur/400 West Granary District Extension | • | | • | • |
| SLC-Downtown-University Streetcar | | | | • |
| Research Park Extension | • | | • | |

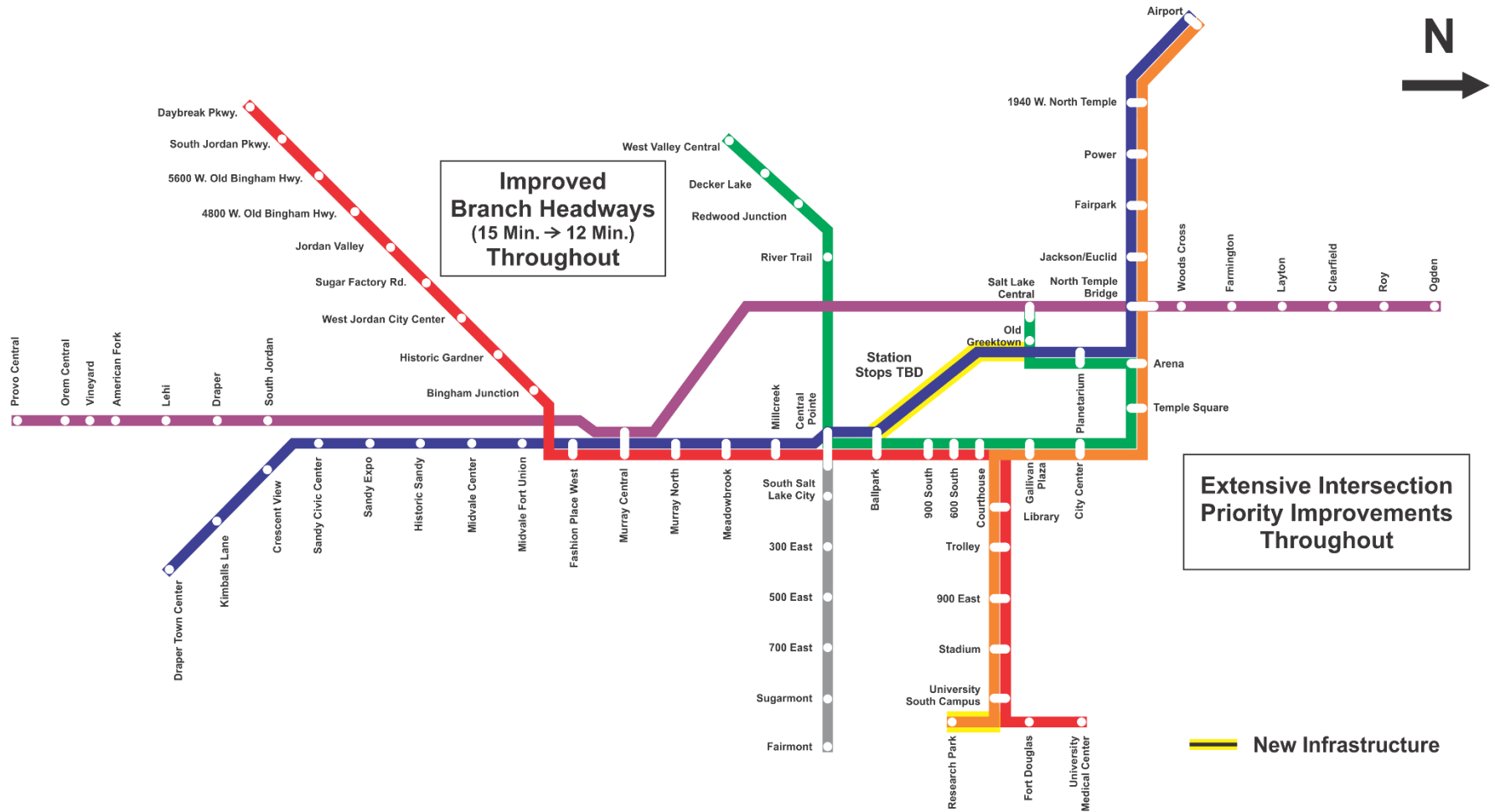

Figure 12 – Future of Light Rail Study Improved Frequency Scenario (system expansion highlighted in yellow)

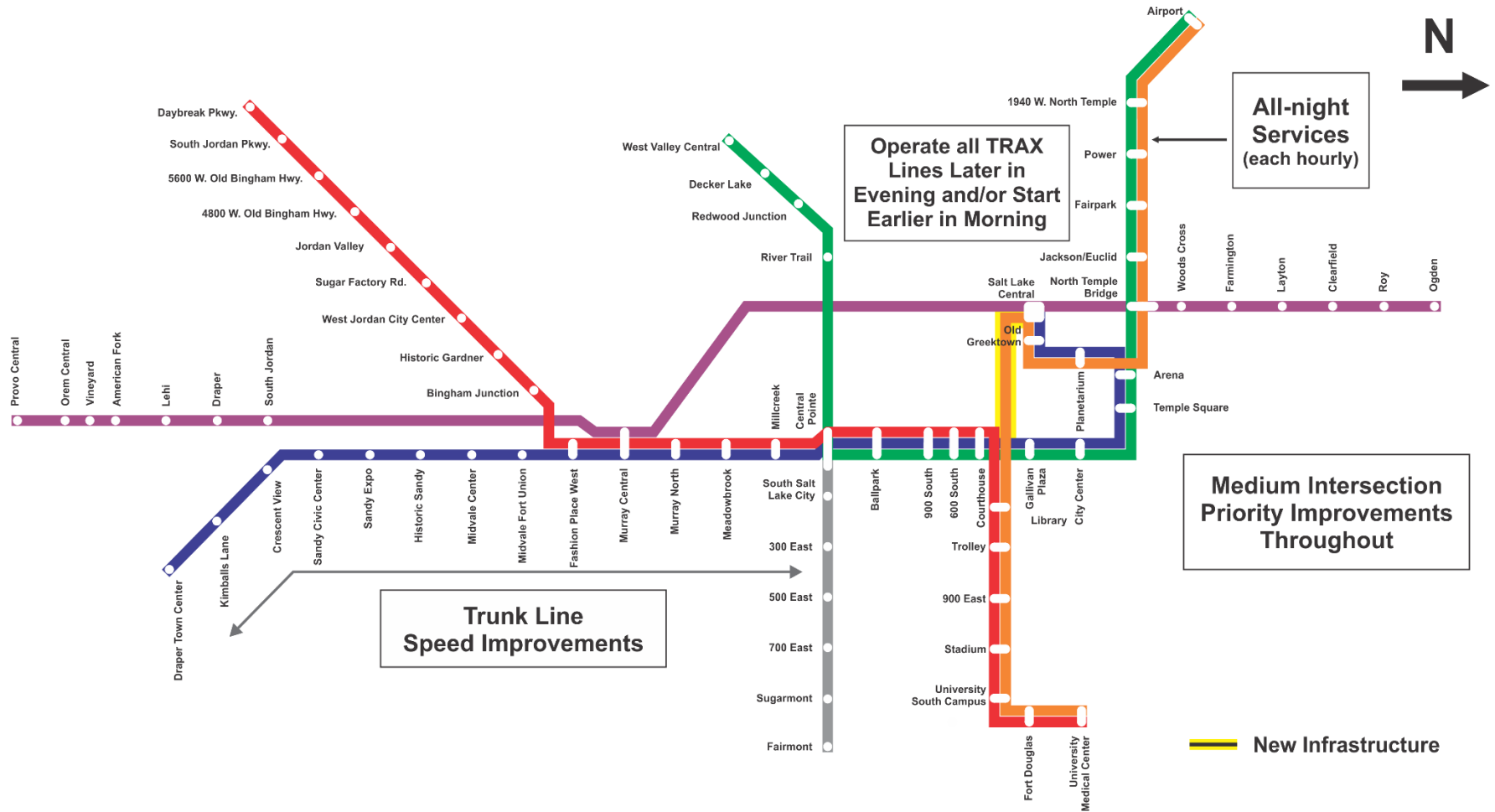

Figure 13 – Future of Light Rail Study Improved Span of Service Scenario (system expansion highlighted in yellow)

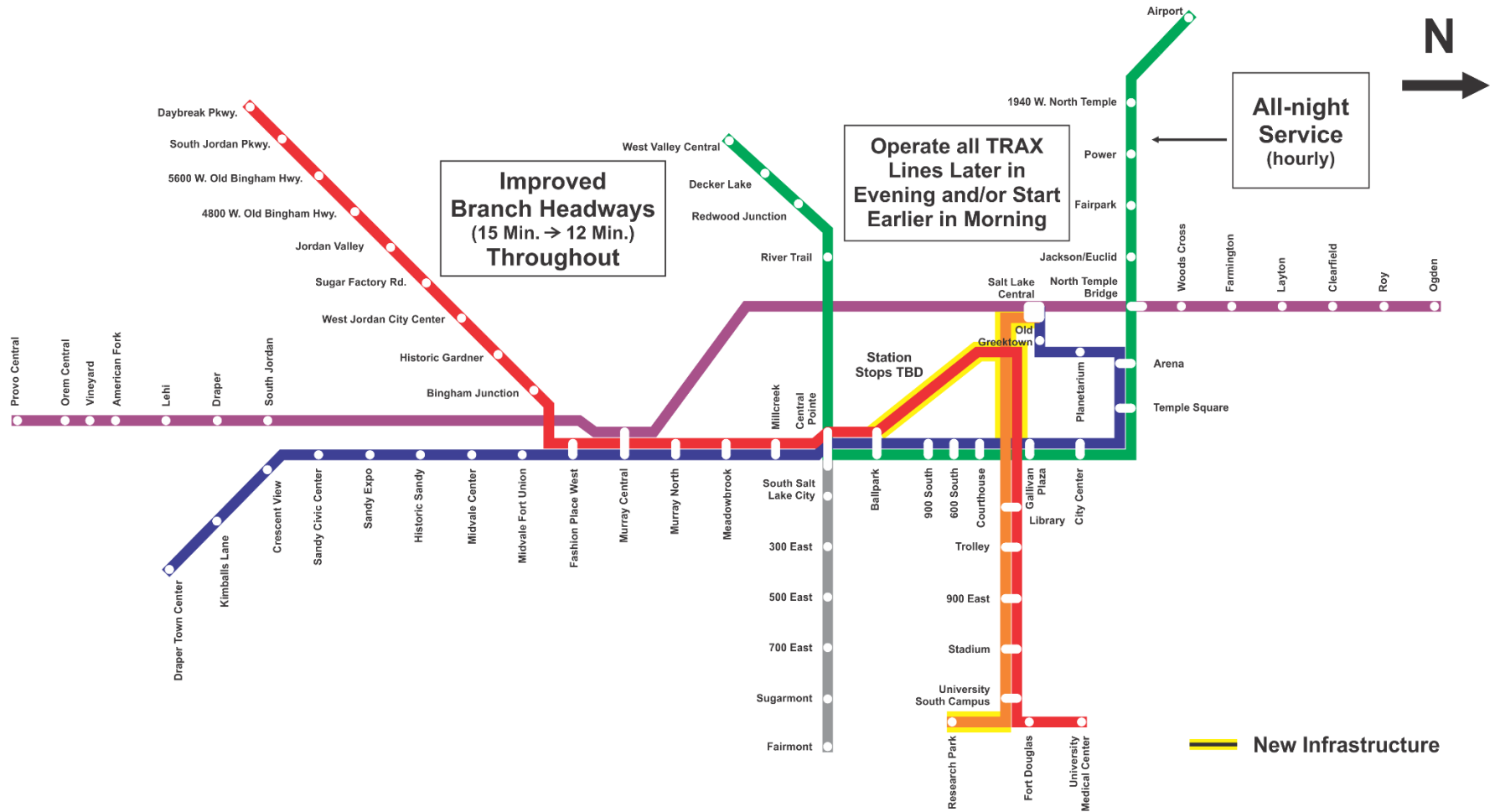

Figure 14 – Future of Light Rail Study Greater Access Scenario (system expansion highlighted in yellow)

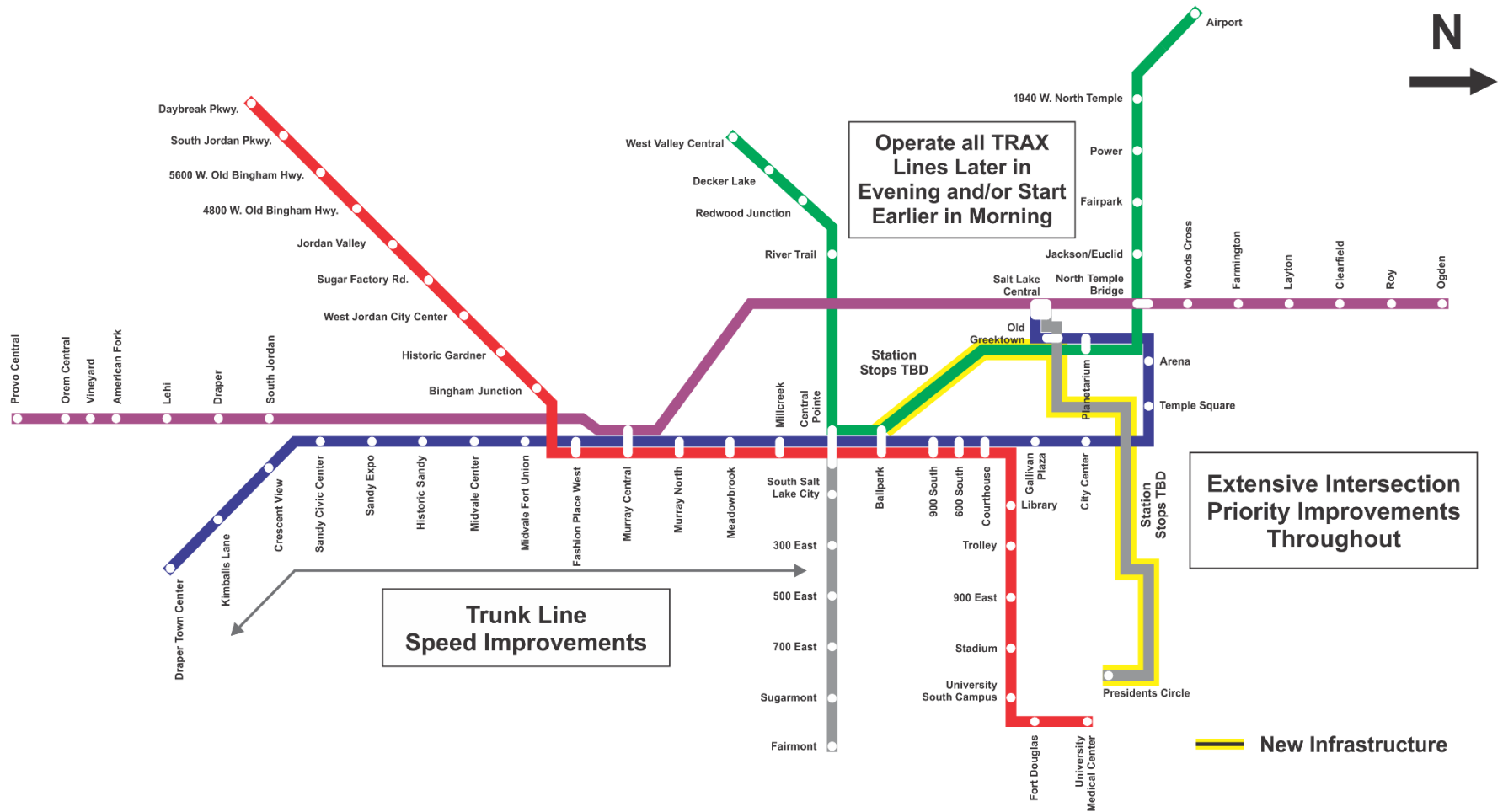

Figure 15 – Future of Light Rail Study Improved Travel Time Scenario (system expansion highlighted in yellow)

Light Rail Strategic Plan Appendices

10 Appendix A – Strategic Plan Ridership and Accessibility Analysis

To measure the ridership effects of the different Future of Light Rail scenarios and final strategic plan, the project team worked with UTA staff to use the Wasatch Front Travel Demand Model (WF TDM). UTA staff ran the models with support, input, and review by Consultant Team member Fehr & Peers. The model is a four-step travel demand model used for forecasting future transportation demand for the highway and transit system in the region. The model includes Utah, Salt Lake, and Davis Counties as well as urban portions of Weber and Box Elder Counties.

The model estimates the travel patterns of people based on land use, sociodemographic characteristics, and available transportation networks. The tool forecasts where people are likely to travel and what mode they may take based on the distribution of households and employment and then assigns trips onto facilities that represent the best route for each trip. The WF TDM is one of the key tools used for developing the RTPs for WFRC and MAG. It is used in almost every major highway and transit project development process, including previous light rail projects.

10.1 Forecasting Tool

Version 8.3.2 of the WF TDM was selected as the best tool available for forecasting transit ridership and associated metrics. This version of the model includes recalibration of the mode choice model to 2019 observed transit data and reflects the most recent updates to the regional transportation plan future networks. Updates to the model also include modifications to the bus network to better reflect existing UTA service.

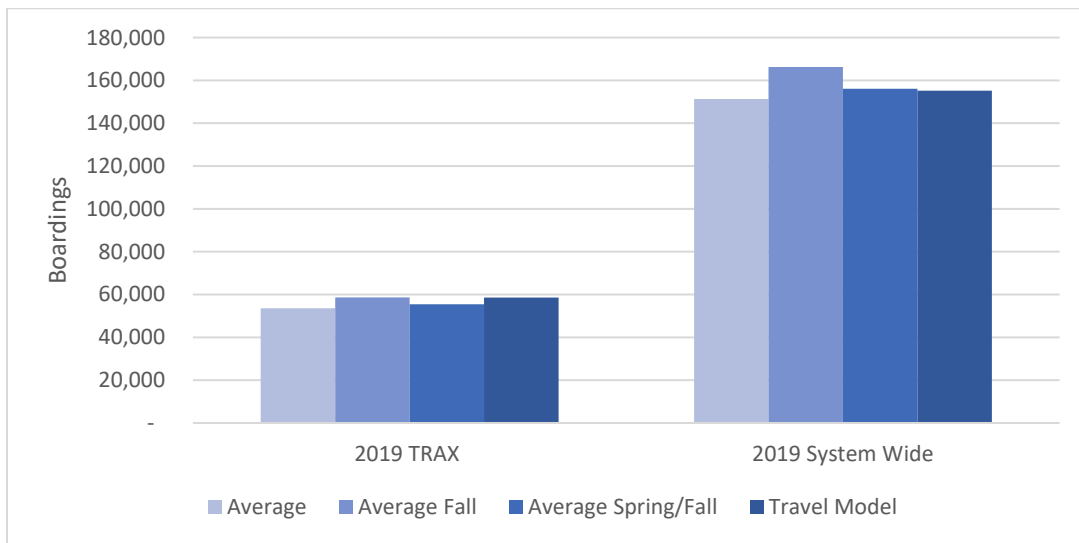

Figure 16 –Model to Observed 2019 Light Rail Boardings Comparison

Figure 16 provides a comparison of 2019 observed weekday boardings to base year 2019 travel model boardings at both a system level and for the TRAX light rail mode. Baseline model boardings are well within +/-20% of observed, which is

the industry standard. Total boardings are 3% high compared to the average weekday boardings for 2019 while TRAX boardings are 9% high.

10.2 Assumptions

Through coordination with UTA, the project team determined that the Future of Light Rail forecasting measures would use a common horizon year of 2050 for analysis. The travel model land used for the RTP was assumed for all scenarios, except for a modification made to the Research Park Traffic Analysis Zone (TAZ), which was modified to better reflect land use plans for the area. Similarly, the 2050 RTP funded highway network was assumed for all scenarios. Long-range plans are “fiscally constrained,” meaning that only those new facilities and recommended improvements which could be funded using existing and reasonably anticipated revenue streams are included in the RTP. Projects that are needed but are not able to be funded with existing or reasonably anticipated revenue streams are identified as “unfunded.” For the purpose of this project, unfunded projects were not assumed. Funded highway projects were included.

Other than specific light rail improvements included in a given scenario, the transit network was held constant for all forecast scenarios. Since transit funding is less certain than highway funding, UTA and the project team determined that only projects that are currently fully funded and committed would be included in the baseline transit network, but any projects identified in the RTP that required new funding would not be included. This means that there was only a short list of transit projects assumed by 2050 for the FOLR Study scenarios. These included an infill light rail station at 600 South in downtown Salt Lake City and an infill FrontRunner station in Vineyard (both since completed), as well as funded components of the 5-year service plan. All other aspects of the transit network were kept the same as existing conditions. This was done to isolate the impacts of operational changes and capital projects directly related to the light rail system, providing an “apples to apples” comparison between scenarios.

House Bill 462, passed into law in 2022, has the potential to increase development density around TRAX stations in ways that are more intense than the future land use assumptions included in the travel demand model. The bill’s Station Area Planning Requirements are intended to maximize development potential in appropriate areas through a collaborative city-led planning approach, allowing cities to determine how best to meet shared objectives without mandating a specific approach or zoning. The bill requires cities to complete Station Area Planning for all Utah passenger rail and BRT stations with dedicated lanes. The station density implications of H.B. 462 will require several years before they are understood; the law may result in higher future TRAX travel demand than was predicted for the Light Rail Strategic Plan.

10.3 Travel Demand Model QA/QC Process and Methodology

UTA staff coded the scenario model runs and ran the model based on direction from the project team. This included updating link level speeds based on average speeds produced by the operations simulation modeling for each scenario. Completed scenario model inputs and outputs were shared with the project team to review the model set up, summarize results, and develop metrics. This also allowed for a second check of model inputs and results, allowing coding errors and other issues to be found and resolved more quickly.

Checks included the following:

- + A consistent 2050 socioeconomic dataset was used for each scenario
- + A consistent 2050 highway network was used for each scenario
- + A consistent transit network was used for each scenario, except for modifications to light rail
- + Headway assumptions were consistent with the scenario
- + The number and location of stations were consistent with the scenario
- + Average speeds from the operations modeling for each scenario were correctly transferred to the model network rail links

10.4 Travel Demand Model Metrics

Several metrics from the travel model were assessed beyond ridership for reporting and comparing scenarios. The final list of metrics included:

- **Daily Transit Trips:** The total number of transit trips taken across the model region. This metric was used to understand the difference in total transit system ridership between each scenario. Daily transit trips represent linked trips which refers to the total number of transit riders. This helps to isolate if new transit trips are being added, or if trips are shifting from another transit mode. This is a standard output from the travel demand model.
- **Daily Transit Boardings:** The total number of transit boardings across all transit modes in the model region. This metric was used to understand the difference in total transit system boardings between each scenario. Boardings are different than trips as they represent unlinked trips. Unlinked trips are the number of times passengers board public transportation vehicles where passengers are counted each time they board a vehicle no matter how many vehicles they use to travel from their origin to their destination. This is a standard output from the travel demand model.
- **Light Rail Daily Boardings:** The total number of boardings at all TRAX stations on an average weekday. This metric was used to understand the difference in ridership on the light rail system between each scenario. This is a standard output from the travel demand model.
- **Peak Load Line per Train:** The number of passengers on the train during the peak trip for each route. This metric was used to help estimate the number of light rail vehicles needed to accommodate the peak passenger load. This was a metric that required additional post-processing of travel model outputs. The process used is described below.
- **Average number of jobs within a 45-minute transit trip in Salt Lake County:** The average number of jobs that are accessible within a 45-minute transit trip in the county where the light rail system operates. This metric was used to estimate if and how improvements to light rail improve access to residents. This metric required additional post processing of travel model outputs. The process used is described below.
- **Average number of jobs within a 45-minute transit trip for Equity Focus Areas:** The average number of jobs that are accessible within a 45-minute transit trip for areas designated by WFRC as “Equity Focus Areas”¹⁰. This metric was used to estimate if and how improvements to light rail improve access to residents in census blocks groups identified as meeting the following criteria: greater than 25% low-income, greater than 40% persons of color, or greater than 10% zero-car households. This metric required the same post processing of travel model outputs as the county level metric. A map of the equity focus areas in Salt Lake County is provided in Figure 17.

¹⁰ WFRC, under the direction of its committees and Council, utilizes an Equity Focus Areas framework as an important input to its transportation planning efforts. For analysis purposes, Equity Focus Areas are those census block groups where any of the following criteria is met ; Greater than 25% Low-Income, Greater than 40% Persons of Color, Greater than 10% Zero-Car Households. Data was accessed from <https://data.wfrc.org/datasets/equity-focus-areas/explore>

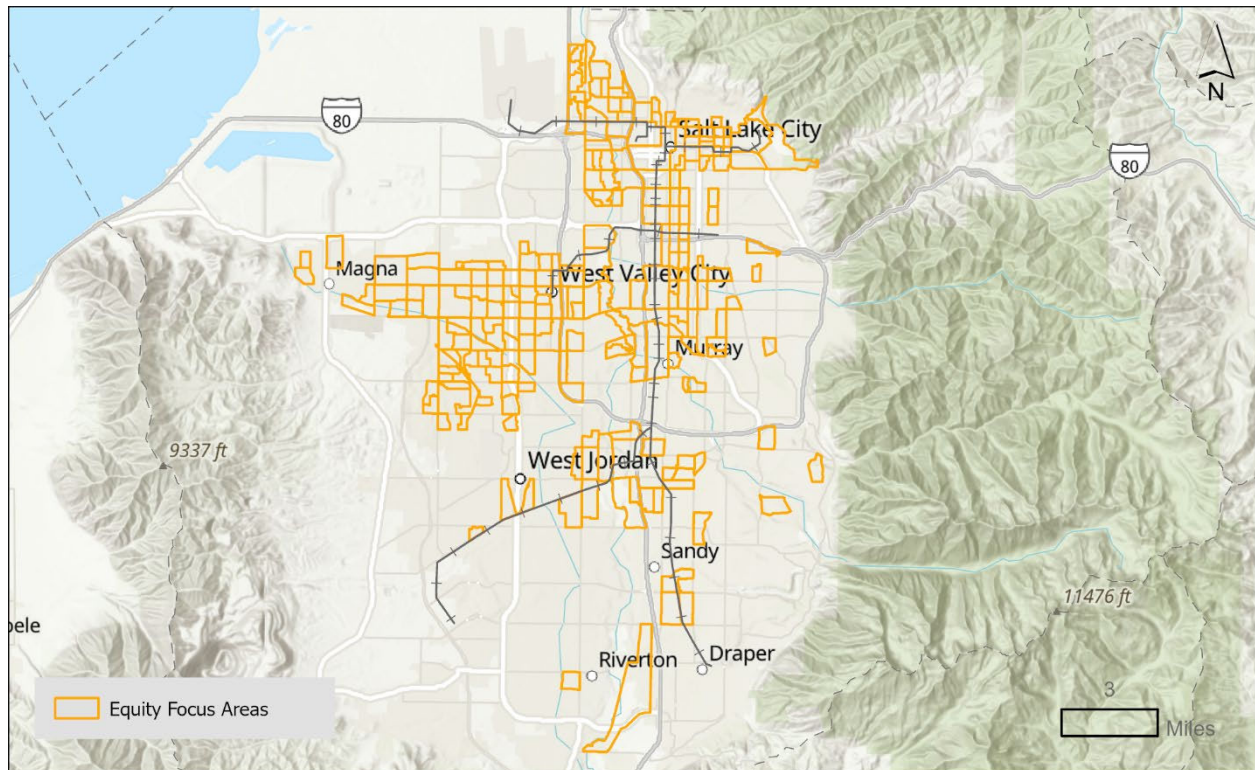

Figure 17 –Equity Focus Areas

10.4.1 Peak Load Line per Train Methodology

The WF TDM transit outputs are processed for peak and off-peak time periods and are not developed per trip. However, it was important for the FOLR Study to estimate peak loading to determine the maximum number of vehicles needed for operations. The Study team developed a post-processing step to develop these estimates. The workflow included:

- + Using the peak light-rail transit assignment output files, summarize the segment passenger volume. Note that off-peak data was not included in the analysis. Additionally, multiple model outputs had to be combined and summarized together because the outputs are broken out by transit mode, mode of access, and location of trips (central business district and non-central business district). Commuter rail modes also had to be included since the model mechanics report the highest mode used in the mode choices step. The following output tables were used in this process
 - + asn_linkd7_Pk – assignment of peak period drive access boardings for the light rail mode
 - + asn_linkw7_outsideCBD_Pk – assignment of peak period walk access boardings for the light rail mode outside of the CBD
 - + asn_linkw7_cbd_Pk – assignment of peak period walk access boardings for the light rail mode inside of the CBD
 - + asn_linkd8_cbd_Pk – assignment of peak period drive access boardings for the commuter rail mode inside of the CBD
 - + asn_linkd8_outsideCBD_Pk – assignment of peak period drive access boardings for the commuter rail mode outside of the CBD

- + asn_linkw8_cbd_Pk – assignment of peak period walk access boardings for the commuter rail mode inside the CBD
- + asn_linkw8_outsideCBD_Pk – assignment of peak period walk access boardings for the commuter rail mode outside the CBD

- + Filter the data based on route to only process volumes for the light rail lines
- + Factor peak period to peak hour. This factor was based on observed data provided by UTA from 2019 and 2021
- + Find the maximum load value by direction for each route
- + Factor the maximum load value by a base model factor. This factor was derived by comparing 2019 travel model run output to observed 2019 Peak Hour Averages provided by UTA
- + Convert the peak hour data into a peak 15-minute passenger load. This assumed that 29% of peak hour volumes occur during the peak 15 minutes and is based on a statistical analysis of Automatic Passenger Counter (APC) data provided by UTA

The final result of this processing served as the final metric for each route.

10.4.2 Average Number of Jobs within a 45-minute Transit Trip in Salt Lake County and Equity Focus Areas Methodology

The FOLR Study team used a script that used the scenario socioeconomic, and the transit skim free-flow matrix file to develop a Traffic Analysis Zone (TAZ) based output. The script summarizes the number of jobs available via transit within 45 minutes for each TAZ. The transit time includes the initial wait time, transfer wait time, and in-vehicle trip time. Once the TAZ level data output was created it was joined in GIS to the WF TDM TAZ file. This was used to develop comparative maps of the scenarios. Additionally, TAZs within Salt Lake County were selected and used to develop the final metric using the average number of jobs for the selected TAZs.

To focus specifically on equity areas, only TAZs in Salt Lake County that intersected with the WFRC Equity Focus Area census block groups were selected and analyzed.

10.5 Travel Model Results

Each Future of Light Rail scenario was coded into the WF TDM, including the Future Baseline and the final Strategic Plan scenario. Table 23 provides a summary of the outputs from the modeled scenarios.

| Table 23 – Daily Transit Trips | | |
|--|---------------------|---------------------------------|
| | Daily Transit Trips | % Increase from Future Baseline |
| Future Baseline | 177,800 | |
| Scenario 1 (Improved Frequency) | 190,300 | +7% |
| Scenario 2 (Improved Span of Service) | 184,800 | +4% |
| Scenario 3 (More Access) | 185,300 | +4% |
| Scenario 4 (Improved Travel Time) | 181,700 | +2% |
| Strategic Plan | 184,500 | +4% |

Daily transit trips were highest under Scenario 1 (Improved Frequency), which had an increase of 7% over the Future Baseline. Scenarios 2, 3, and the Strategic Plan all saw a 4% increase over the Future Baseline. Scenario 4 (Improved Travel Time) had the lowest increase of all the scenarios, with only a 2% increase over the Future Baseline. Increases in Scenario 1 (Improved Frequency) can likely be attributed to changing headways from 15 to 12 minutes. While this was

also included in Scenario 3 (More Access), Scenario 1 (Improved Frequency) also included two routes serving the corridor between downtown Salt Lake City and the Airport, while Scenario 3 (More Access) had only one route serving this area.

10.5.1 Daily Transit Boardings

| Table 24 – Daily Transit Boardings | | |
|---------------------------------------|-------------------------|---------------------------------|
| | Daily Transit Boardings | % Increase from Future Baseline |
| Future Baseline | 232,800 | |
| Scenario 1 (Improved Frequency) | 248,400 | +7% |
| Scenario 2 (Improved Span of Service) | 241,100 | +4% |
| Scenario 3 (More Access) | 242,400 | +4% |
| Scenario 4 (Improved Travel Time) | 236,300 | +2% |
| Strategic Plan | 237,700 | +2% |

Daily transit boardings, summarized Table 24, show similar results to daily transit trips. However, boarding increases for the Strategic Plan only show a 2% increase while daily transit trips increase by 4%. This suggests that the Strategic Plan has a lower transfer rate which results in fewer unlinked boardings, but higher overall ridership on the system.

10.5.2 Light Rail Boardings

| Table 25 – Light Rail Boardings | | |
|---------------------------------------|----------------------------|---------------------------------|
| | Daily Light Rail Boardings | % Increase from Future Baseline |
| Future Baseline | 95,500 | |
| Scenario 1 (Improved Frequency) | 111,200 | +16% |
| Scenario 2 (Improved Span of Service) | 103,900 | +9% |
| Scenario 3 (More Access) | 105,000 | +10% |
| Scenario 4 (Improved Travel Time) | 103,600 | +8% |
| Strategic Plan | 102,800 | +8% |

While Table 25 shows that all scenarios have modest growth from the Future Baseline for both daily light rail boarding and systemwide boardings, it is important to note that there is more significant growth forecasted between the model base year of 2019 and the Future Baseline, which represents a 2050 condition. As shown in Table 26, systemwide boardings are projected to increase 50% between the 2019 mode base year and Future Baseline, while light rail boardings are projected to increase 63%. The Strategic Plan adds to this increase, resulting in a 52% increase in systemwide boardings and 71% increase in light rail boardings.

| Table 26 – Light Rail and Total Transit Boardings Change from 2019 | | | | | |
|--|------------------------|--------------------|-----------------------|--|---------------------------------|
| | Future Baseline (2050) | Increase from 2019 | Strategic Plan (2050) | Strategic Plan Change from Future Baseline | Strategic Plan Change from 2019 |
| Daily Total Light Rail Boardings | 95,500 | 63% | 102,800 | +8% | +71% |
| Daily Total Transit Boardings | 232,800 | 50% | 237,600 | +2% | +52% |

10.5.3 Peak Load per Line

| Table 27 – Peak Passenger Load | |
|--|-----------|
| Route | Peak Load |
| Future Baseline | |
| Blue Line | 229 |
| Red Line | 346 |
| Green Line | 234 |
| S-Line | 29 |
| Scenario 1 (Improved Frequency) | |
| Blue Line | 195 |
| Red Line | 316 |
| Green Line | 156 |
| S-Line | 30 |
| Orange Line | 257 |
| Scenario 2 (Improved Span of Service) | |
| Blue Line | 217 |
| Red Line | 223 |
| Green Line | 148 |
| S-Line | 28 |
| Orange Line | 289 |
| Scenario 3 (More Access) | |
| Blue Line | 197 |
| Red Line | 252 |
| Green Line | 236 |
| S-Line | 29 |
| Orange Line | 207 |
| Scenario 4 (Improved Travel Time) | |
| Blue Line | 262 |
| Red Line | 329 |
| Green Line | 233 |
| S-Line | 28 |
| Downtown Streetcar | 163 |
| Strategic Plan | |
| Blue Line | 246 |
| Red Line | 237 |
| Green Line | 105 |
| S-Line | 67 |
| Orange Line | 107 |

Forecast peak load per line is shown in Table 27. This information was used to determine the maximum number of vehicles needed to provide service, consistent with UTA Light Rail Service Standards.

10.5.4 Average Number of Jobs within a 45 Minute Transit Trip in Salt Lake County

| | Average Number of Jobs | % Increase from Future Baseline |
|--|------------------------|---------------------------------|
| Future Baseline | 374,200 | |
| Scenario 1 (Improved Frequency) | 386,800 | +3% |
| Scenario 2 (Improved Span of Service) | 378,300 | +1% |
| Scenario 3 (More Access) | 381,000 | +2% |
| Scenario 4 (Improved Travel Time) | 379,700 | +1% |
| Strategic Plan | 376,400 | +1% |

Accessibility did not substantially change between the scenarios. Scenario 1 (Improved Frequency) and Scenario 2 (Improved Span of Service) had the highest change in average job accessibility due to the improved headways. All other scenarios had approximately the same change in accessibility. This is not unexpected since extensions of the light rail system are limited to the Granary District and Research Park, both of which already have some transit accessibility. While transit accessibility improves for these areas, the improvements are limited to just a few TAZs. Routing changes between the scenarios and the Future Baseline Scenario also complicate the job accessibility calculation.

10.5.5 Average Number of Jobs within a 45 Minute Transit Trip in Salt Lake County Equity Focus Areas

| | Average Number of Jobs | % Increase from Future Baseline |
|--|------------------------|---------------------------------|
| Future Baseline | 494,100 | |
| Scenario 1 (Improved Frequency) | 510,200 | +3% |
| Scenario 2 (Improved Span of Service) | 500,000 | +1% |
| Scenario 3 (More Access) | 502,300 | +2% |
| Scenario 4 (Improved Travel Time) | 501,800 | +2% |
| Strategic Plan | 496,800 | +1% |

Equity area analysis results were like Salt Lake County job accessibility results. As shown in Table 29, Scenario 1 (Improved Frequency) had the highest increase in average job accessibility, while the Strategic Plan had the lowest increase. However, none of the scenarios had lower accessibility than the Future Baseline, meaning that each scenario improved job accessibility for residents in Equity Focus Areas and in-line. Additionally, the increases were similar to the larger Salt Lake County population, indicating that Equity Focus Areas saw increases proportionate to the rest of Salt Lake County.

10.5.6 Light Rail Trains per Hour in Equity Focus Areas

This measure was not derived from the travel model. However, in order to better assess how the scenarios impacted access to transit for Equity Focus Areas, an off-model analysis was conducted to summarize the number of trains per hour at stations located in an Equity Focus Area. The results are shown in Table 30. This analysis assumed that there would be three stations for scenarios where light rail served the Granary District. It also assumed three stations would be included for scenarios where light rail operated on 400 South west of Main Street to Salt Lake Central. For Scenario 4 (Improved Travel Time), which included the downtown Streetcar, 21 stations were assumed to be part of the project.

| Table 30 – Equity Focus Station Service Levels | | | | |
|--|--------------------------------------|---|---|--|
| | Number of Equity Focus Area Stations | Number of Equity Focus Area Stations with 4 Trains per Hour | Number of Equity Focus Area Stations with 8 Trains per Hour | Number of Equity Focus Area Stations with 12 Trains per Hour |
| Future Baseline | 39 | 27 | 8 | 4 |
| Scenario 1 (Improved Frequency) | 43 | 20 | 22 | 1 |
| Scenario 2 (Improved Span of Service) | 42 | 15 | 23 | 4 |
| Scenario 3 (More Access) | 46 | 26 | 19 | 1 |
| Scenario 4 (Improved Travel Time) | 60 | 49 | 10 | 1 |
| Strategic Plan | 46 | 18 | 27 | 1 |

In every scenario, the number of Equity Focus Area stations increased, as shown in Table 31. The highest increase was in Scenario 4 (Improved Travel Time) which is largely based on the assumption of closely spaced stations added to the system as part of the Downtown Streetcar project. The Strategic Plan scenario and Scenario 3 (More Access) added the second highest number of Equity Focus Area Stations. The Strategic Plan also had the highest number of Equity Focus Area Stations with 8 trains per hour. Almost all the scenarios reduced the number of Equity Focus Area Stations with 12 trains per hour, with the exception of Scenario 2 (Improved Span of Service). This is due to changing one of the current routes that serves the area between Ballpark and Courthouse station to serve the Ballpark Spur/Granary District instead. However, in each scenario the number of Equity stations that gained trains per hour is higher than the number of stations that lost trains per hour, as shown in Table 31.

| Table 31 – Equity Area Station Service Increases and Decreases | | |
|--|--|---|
| | Number of Equity Focus Area Stations that Lose Trains per Hour Compared to Future Baseline | Number of Equity Focus Area Station that Gain Trains per Hour Compared to Future Baseline |
| Scenario 1 (Improved Frequency) | 3 | 11 |
| Scenario 2 (Improved Span of Service) | 0 | 15 |
| Scenario 3 (More Access) | 3 | 5 |
| Scenario 4 (Improved Travel Time) | 7 | 24 |
| Strategic Plan | 3 | 13 |

Overall, this analysis shows that Equity Focus Areas saw expanded and improved service with each Scenario and with the Strategic Plan. While three stations, 900 South, 600 South, and Courthouse lost service levels, dropping from 12 trains per hour to 8 trains per hour, this allows a larger number of Equity Service Area Stations to operate in the Strategic Plan.

10.6 Granary District and Research Park Service Population and Employment Growth

As shown in Table 32, the Granary District and Research Park are two areas that would be served by expansions of the light rail system through the implementation of the Strategic Plan. Currently, the Granary District has some employment, but much of the area is underutilized. Population in this area is also limited. Research Park is already a regional employment hub but also has a very limited population. However, both areas are also expected to grow substantially by 2050. The TAZ forecasts for the Granary District show a 280% increase in population between 2019 and 2050, and a 92% increase in employment. Research Park TAZ forecasts show a 1,521% increase in population and a 19% increase in employment during this same period. These two areas capture approximately 4% of the total population growth anticipated in Salt Lake County and 1% of the employment growth, making them key regional growth nodes. Figure 18 provides a map of the projected growth by TAZ for the County.

Table 32 – Projected Population Growth 2019-2050 in Selected Strategic Plan Focus Areas

| Location | 2019 Population | 2050 Population | Population Change (%) | 2019 Employment | 2050 Employment | Employment Change (%) |
|--------------------------------------|-----------------|-----------------|-----------------------|-----------------|-----------------|-----------------------|
| Granary District¹¹ | 1,663 | 6,319 | + 280% | 2,804 | 5,373 | + 92% |
| Research Park¹² | 844 | 13,676 | + 1,521% | 10,266 | 12,208 | + 19% |
| Salt Lake County | 1,143,737 | 1,514,780 | + 32% | 846,408 | 1,200,280 | + 42% |

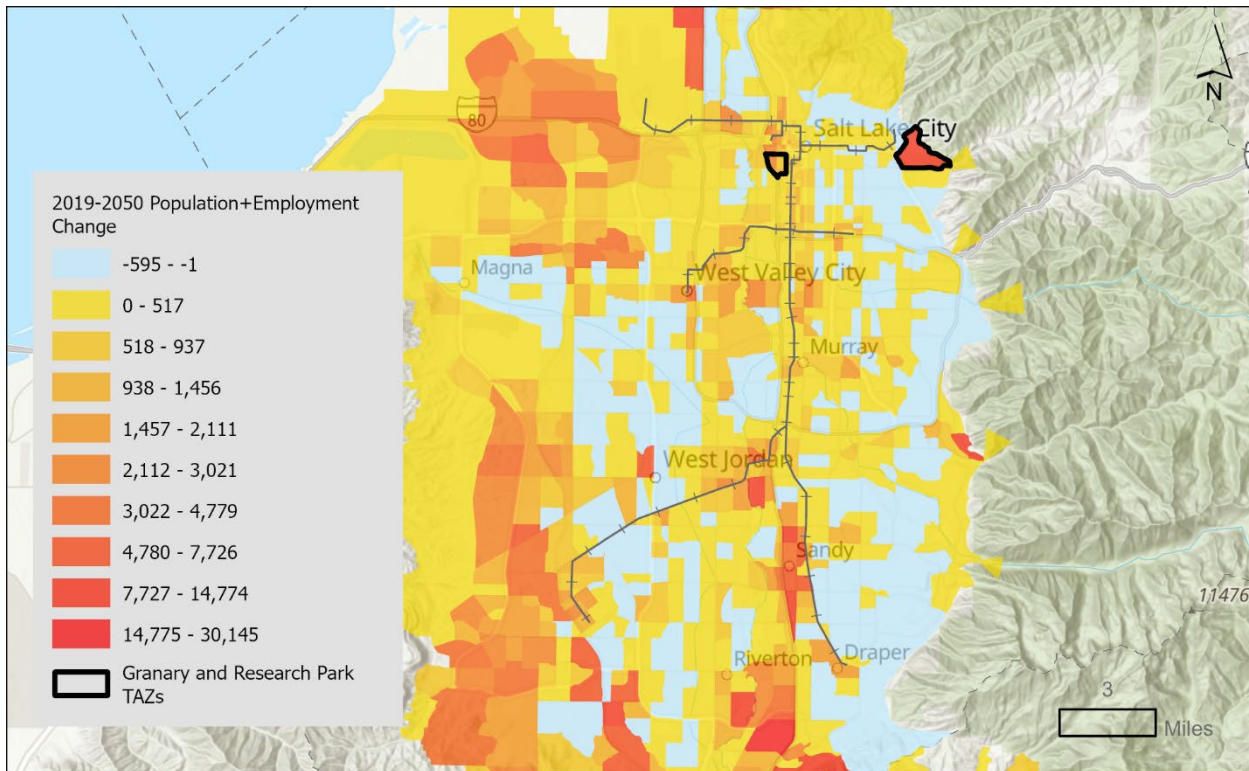

Figure 18 –Salt Lake County TAZ Projected Growth

¹¹ Includes TAZ numbers 992, 1003, 1004, 1009, 1010, 1095

¹² TAZ number 1077

11 Appendix B – Operations Simulation Results

Network operations simulation was used extensively in FOLR to test individual capital improvements as well as to understand how future operating concepts integrate with the planned network infrastructure. The results of 24-hour network simulations were used to provide station-to-station travel times and average speeds by scenario for input into the regional travel demand model that quantified ridership benefits of a wide range of network improvements including those advanced to the Strategic Plan recommendations.

The simulation process started with the development of a baseline model reflecting the 2019 configuration and operations of the light rail network. The baseline model served to calibrate the model to existing TRAX travel times, congestion and on-time performance. Calibration involves adjusting individual line segment speeds, dwell times and operator performance such that simulated velocity plots match those provided for actual operations. It also involves adjusting simulated traffic signal probabilities and dwell time distributions such that simulated on-time performance on each line matches recent UTA trends.

The Baseline simulation model was developed using UTA-provided track charts and signal control line drawings. The TrainOps simulation model includes the full light rail and streetcar network:

- + TRAX Blue Line: between Salt Lake Central and Draper Town Center
- + TRAX Red Line: between University Medical Center and Daybreak Parkway
- + TRAX Green Line: between Airport and West Valley Central
- + S-Line Streetcar: between Central Pointe and Fairmont

A Future Baseline Scenario was developed from the Existing Baseline model, with the intention of being used as a baseline against which to compare the simulated results of the Strategic Plan improvements. The Future Baseline added the new 600 South Station and relocated Airport Station, neither of which were in service in 2019 but both of which have now been completed.

Phase 1 of the Study also tested six “build” scenarios:

- + Phase 1 Scenario 1: Intersection Priority Improvements
- + Phase 1 Scenario 2: Trunk Line Curve Speed Improvements
- + Phase 1 Scenario 3: Additional Intersection Priority Improvements
- + Phase 1 Scenario 4: Granary District/West Downtown Network Improvements with New Orange Line
- + Phase 1 Scenario 5: Research Park Extension
- + Phase 1 Scenario 6: Existing Network with 12-Minute Branch Headways

Refer to the Future of Light Rail Phase 1 Study Report for complete simulation results for the Existing Baseline, Future Baseline and six future Phase 1 scenario simulations. The sections below detail some of the simulation inputs common to all modeled scenarios and present the results of the simulated Strategic Plan network with all recommended capital investments and service changes in place.

11.1 Existing Light Rail Fleet

Two types of vehicles were used in the modeling and simulation – Siemens SD100 and Siemens S70. UTA’s fleet includes a third vehicle type, the SD160, but this was not explicitly modeled as its performance is comparable to the SD100 (the SD160 is capable of operating at 65 mph versus the 55 mph top speed of the SD100 but does not normally attain this

speed in revenue service because of the mixed SD100/SD160 train consists). The SD100 fleet normally operates only on the Blue Line while the S70 fleet serves all other lines. The specifications for the simulated vehicles are shown in Table 33. The underlying tractive effort curves for the two Siemens vehicle types are shown in Figure 19. Note that the SD100 tractive effort curve extends only up to 55 mph, consistent with its operational maximum speed. The S70 vehicle is about 10% heavier than the SD100 so its tractive effort is somewhat higher at most speeds to provide equivalent acceleration to the first generation SD100 fleet.

| Table 33 – Vehicle Specifications for Simulation | | |
|--|---------------|-------------|
| | Siemens SD100 | Siemens S70 |
| Length (ft) | 81.43 | 81.40 |
| Empty Weight (lbs) | 88,000 | 96,499 |
| Number of Axles | 6 | 6 |
| Passenger Capacity (100% Seated) | 60 | 60 |
| Simulated Passenger Weight (Seated) (lbs) | 10500 | 10500 |
| Deceleration Adhesion (%) | 28 | 28 |
| Derate Tractive Power for Auxiliary Load | No | No |
| Design Maximum Speed (mph) | 65 | 65 |
| Operation Maximum Speed (mph) | 55 | 65 |
| Initial Acceleration Limit (mph/s) | 3 | 3 |
| Service Brake Rate (mph/s) | 3 | 3 |
| Rotational Weight (lbs) | 9,000 | 11,023 |
| Rotational Weight as a % of Empty Weight (%) | 10.23 | 11.42 |
| Frontal Area (ft ²) | 102 | 107 |

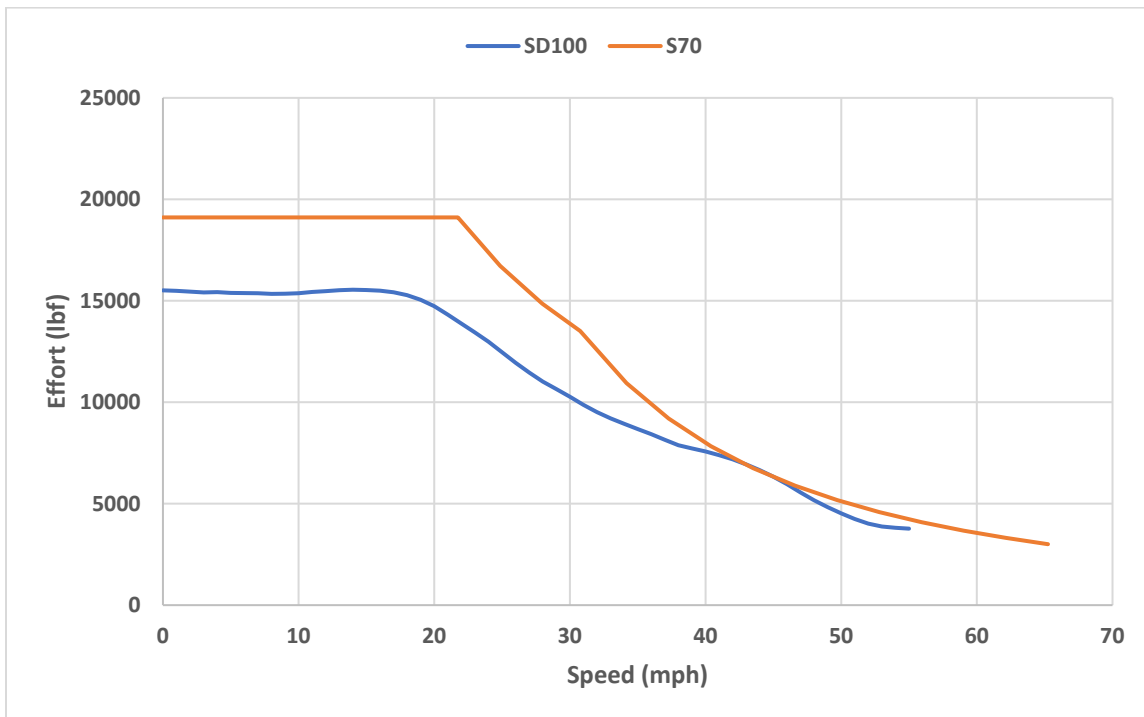

Figure 19 – Siemens SD100 and S70 LRV Tractive Effort Curves

The simulation of Existing Baseline and Future Baseline confirmed the current UTA fleet requirement, which is 87 cars (excluding streetcar fleet requirements of two cars). When the UTA (and industry) target spare margin of 20% is added to this, the resultant overall fleet requirement is 105. This is slightly less than the current light rail fleet total (excluding the three S70 streetcars) of 114 cars. In other words, the 27 cars not presently required to deliver peak service of 87 cars represents a spare margin of about 31%. The Strategic Plan spare margin is assumed to be reduced to 20%, allowing some service expansion without commensurate fleet acquisition.

11.2 Existing Civil Speed Restrictions

The FOLR Study team was directed to model the civil speed restrictions in the northbound and southbound travel directions based on the TRAX Speed Map. In street running segments, (primarily Courthouse to University Medical Center, Ballpark to Salt Lake Central) speeds are generally consistent with adjacent traffic speeds and do not exceed 35 mph. At intersections, 90-degree turns are generally limited to 10 mph. Where TRAX operates in its own right-of-way, maximum speeds are generally 55 to 65 mph with some civil speed restrictions (primarily curves) limiting speed to lower values. Most of the segments with speeds higher than 55 mph are on the Blue and Red Lines south of Fashion Place West.

11.3 Existing Wayside Signaling

TRAX is equipped with a railroad style wayside signal system. The system does not include a cab signal overlay or red signal enforcement using trip stops or Positive Train Control type profiling. The wayside signals and control lines modeled in the simulation are based on the UTA-provided signal control line drawings. With few exceptions, the signal aspect sequences are green (proceed), yellow (caution), red (stop) approaching occupied signal blocks ahead or interlockings where the route has not yet been established. Due to signal control line drawings not matching as-in-service conditions, assumptions were made for the control line connections between Ballpark Station and Sandy Civic Center Station according to instructions received from UTA.

11.4 Existing Intersection Priorities/Delay Probabilities

At 88 intersections between the route of the street-running portion of the TRAX network and cross-streets, the movement of TRAX vehicles are governed by the street traffic signals. At these locations, the trains may be delayed if arrival at the intersection is not synchronized with a permissive phase of the traffic signal cycle.

There are 15 traffic signals along the TRAX lines that use pre-emption in place of priority. With pre-emption, the operations of the signal will be interrupted to allow the train to pass through the signal without stopping. Pre-emption is often used at more isolated traffic signals or locations where the trains are traveling at higher speeds. This also has a more significant impact on vehicle traffic at the intersections.

At the other 73 locations, stopping probabilities and hold times at traffic lights were used to model the chances of TRAX trains having to stop at intersections for red traffic lights. The stopping probabilities and hold times can vary throughout a 24-hour period day. Figure 20 illustrates a TrainOps simulation example of the street signal pattern defining delay probabilities at the intersection of 500 South and 1300- East in the westbound travel direction. This shows, for example, that trains in the morning peak period at this intersection have a 49% probability of needing to stop at this intersection in this direction. If the train does need to stop, based on randomization in TrainOps, it will wait 32 seconds before proceeding. These delay probabilities were developed by the FOLR Study team based on review of traffic controller settings and discussions with UDOT and municipal traffic engineers. Details of the street signal pattern at other intersections are found in Chapter 6 of the Strategic Plan.

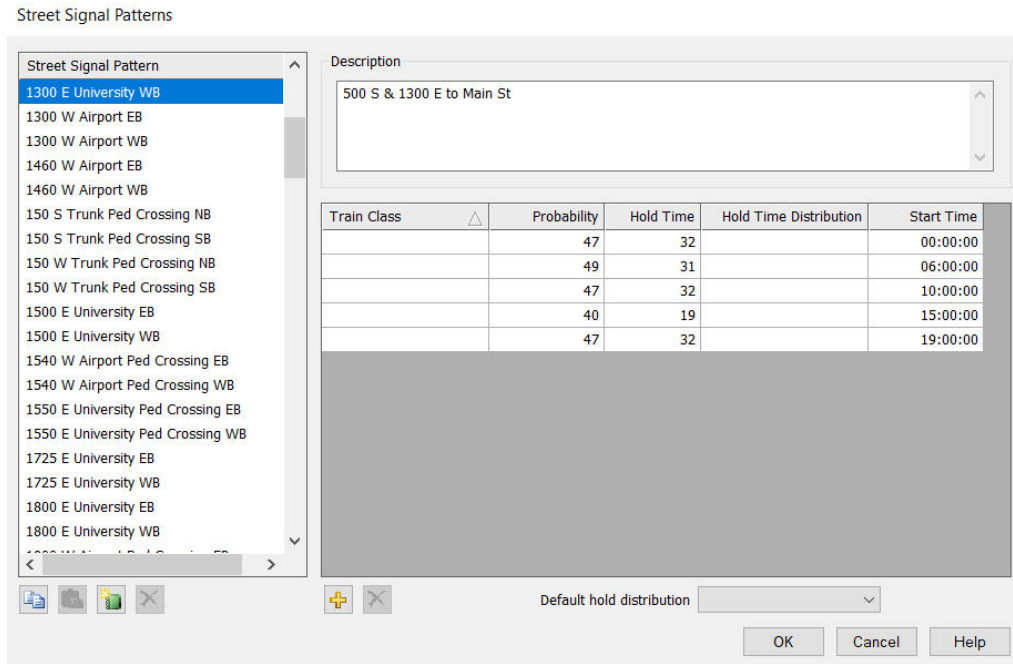

Figure 20 – Example of TrainOps Simulation Intersection Stopping Probabilities and Hold Times

11.5 Existing TRAX Baseline Operating Plan

11.5.1 Existing TRAX Baseline Operating Plan: Schedule

The pre-COVID weekday operating plan that was scheduled to take effective on April 5, 2020 (but was not actually operated due to COVID-related ridership impacts) was provided by the UTA to be used in the simulation. The 24-hour simulation of a full day service plan models the interaction of trains along the Blue, Red and Green Lines as well as on the S-Line . This includes the non-revenue moves needed to bring trains in and out of the Midvale and Jordan River Service Centers, each consisting of a yard and a light rail vehicle maintenance facility.

11.5.2 Existing TRAX Baseline Operating Plan: Train Consists

In the Existing Baseline scenario, the Blue Line runs SD100 vehicles and the Red Line and Green Line run S70 vehicles. The Blue Line and Green Line each run eight trains throughout the day, and the Red Line runs 13 trains. The car counts of these trains varied throughout the day, with trains adding or removing cars (since the time of the baseline simulation, UTA has reduced or eliminated car “cuts” and “adds” during the course of the operating day).

11.5.3 Existing TRAX Baseline Operating Plan: Dwells and Terminal Turn Time

Dwell time data was compiled for the TRAX network from provided Automatic Passenger Counter (APC) data for the 2019 calendar year. To capture the variability in the real-world operation, normal distributions were used to model the dwell times at stations. Figure 21 shows an example of a typical dwell time distribution for one TRAX station in one direction. These distributions were created using a minimum and maximum value, the mean and the standard deviation based on the APC data.

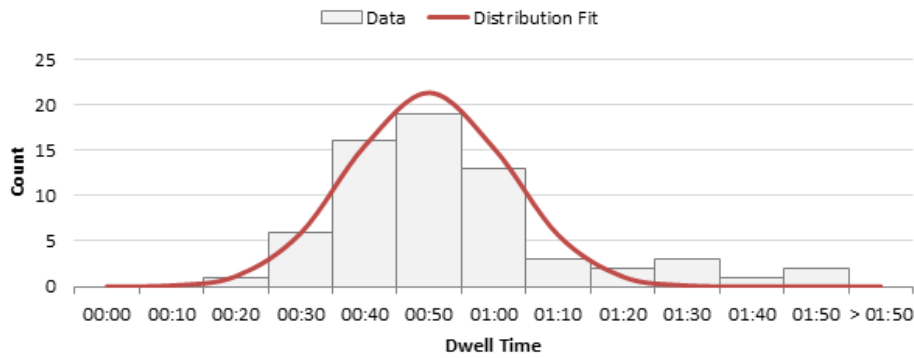

Figure 21 – Example of Normal Distribution

There are specific distributions for each station depending on the time of the day (a.m. peak, p.m. peak, or off-peak), direction and service line (Red, Blue, Green, or S-Line Streetcar). Table 34 is an example of the dwell time distribution for 1940 W North Temple on Green Line.

| Table 34 – Example of Dwell Data for Normal Distribution (seconds) | | | | |
|--|-----|-----|------|--------------------|
| | Min | Max | Mean | Standard Deviation |
| G-1940 W North Temple-PM Peak-NB | 18 | 76 | 39 | 25 |
| G-1940 W North Temple-PM Peak-SB | 19 | 63 | 35 | 21 |
| G-1940 W North Temple-AM Peak-NB | 18 | 57 | 32 | 18 |
| G-1940 W North Temple-AM Peak-SB | 19 | 63 | 34 | 22 |
| G-1940 W North Temple-Off-Peak-NB | 18 | 56 | 31 | 21 |
| G-1940 W North Temple-Off-Peak-SB | 17 | 56 | 30 | 20 |

11.5.4 Existing TRAX Baseline Operating Plan: Minimum Required Train Turn Times

The simulation model uses both scheduled and minimum required train turn times at terminals. During disrupted operations, there may be insufficient time for the Train Operator to walk the train and prepare to depart in the opposite direction, while maintaining schedule. The minimum required turn times were provided by UTA Light Rail Operations with the understanding that they are not for scheduling purposes but rather reflect conscientious Train Operators striving to return to scheduled operation. The reverse turn time was set as 4 minutes at all terminals while the reverse turn time at non-terminal stations was set as 3 minutes. These non-terminal reversing moves usually occur at Central Pointe and Fashion Place West stations, as well as a reversing move within Jordan River Service Center to reach West Valley Central station.

11.6 Existing Operations Calibration

11.6.1 Existing Operations Calibration: Velocity Profiles

For the speed limits calibration, one trip from each line in each direction was simulated to produce the velocity profile of each track; only one trip was running in the network at any time of the simulation to prevent interference that may cause deceleration or stopping of train. The variability was turned off to ensure the trains were able to run at its maximum allowable speed. The speed restrictions were calibrated to match the data collected from the real-world operations on the GPS Data vs TrainOps Simulation Trip Graph Overlay.

11.6.2 Existing Operations Calibration: On-Time Performance

To capture real-world operations more accurately, the simulations were run five times, each receiving a new set of values for dwell times (using the distributions). The average On-Time Performance (OTP) of five sets of simulations was 91.5%, which is above the 90% OTP target. Table 35 shows the comparison of the simulation results and the monthly highest, lowest, and average OTP from the APC data. The lateness threshold in the simulation was set at 4 mins and 59 sec.

| TRAX Line | Monthly Lowest (%) | Monthly Highest (%) | Monthly Average (%) | Simulation Average (%) |
|------------|--------------------|---------------------|---------------------|------------------------|
| Blue Line | 87.2 | 95.8 | 92.9 | 94.7 |
| Red Line | 89.6 | 96.8 | 91.6 | 92.0 |
| Green Line | 85.0 | 97.7 | 93.0 | 86.4 |

11.7 Existing Baseline Simulation Results

11.7.1 Existing Baseline Simulation Results: Delay Graphic

Figure 22 shows the Delay Graphic which presents the average delay per trip based on the baseline simulation results. Intersection delay (represented by circles) refers to the delays at intersections caused by the traffic light, while train delay (represented by triangles) refers to trains stopped due to other trains ahead and conflicting routes reserved or occupied at junctions/crossings. The intersections, junctions and other locations with high delay occurrences became priorities for operational or infrastructure improvements to reduce such delays in the simulated Strategic Plan scenario.

The Delay Graphic shows that most delays are distributed in the north of the network. Comparing to the train delays, intersection delays were making a greater impact on the On-Time Performance. Additionally, trains are more likely to undergo larger intersection delays on the area near Airport Station and West Valley Central. The intersection delays on the segment between 900 South Station and Fort Douglas Station were more significant than other areas.

Train delays were mainly distributed around junctions with the merges near Arena Station, Courthouse Station and Central Pointe Station constituting the most significant train congestion locations.

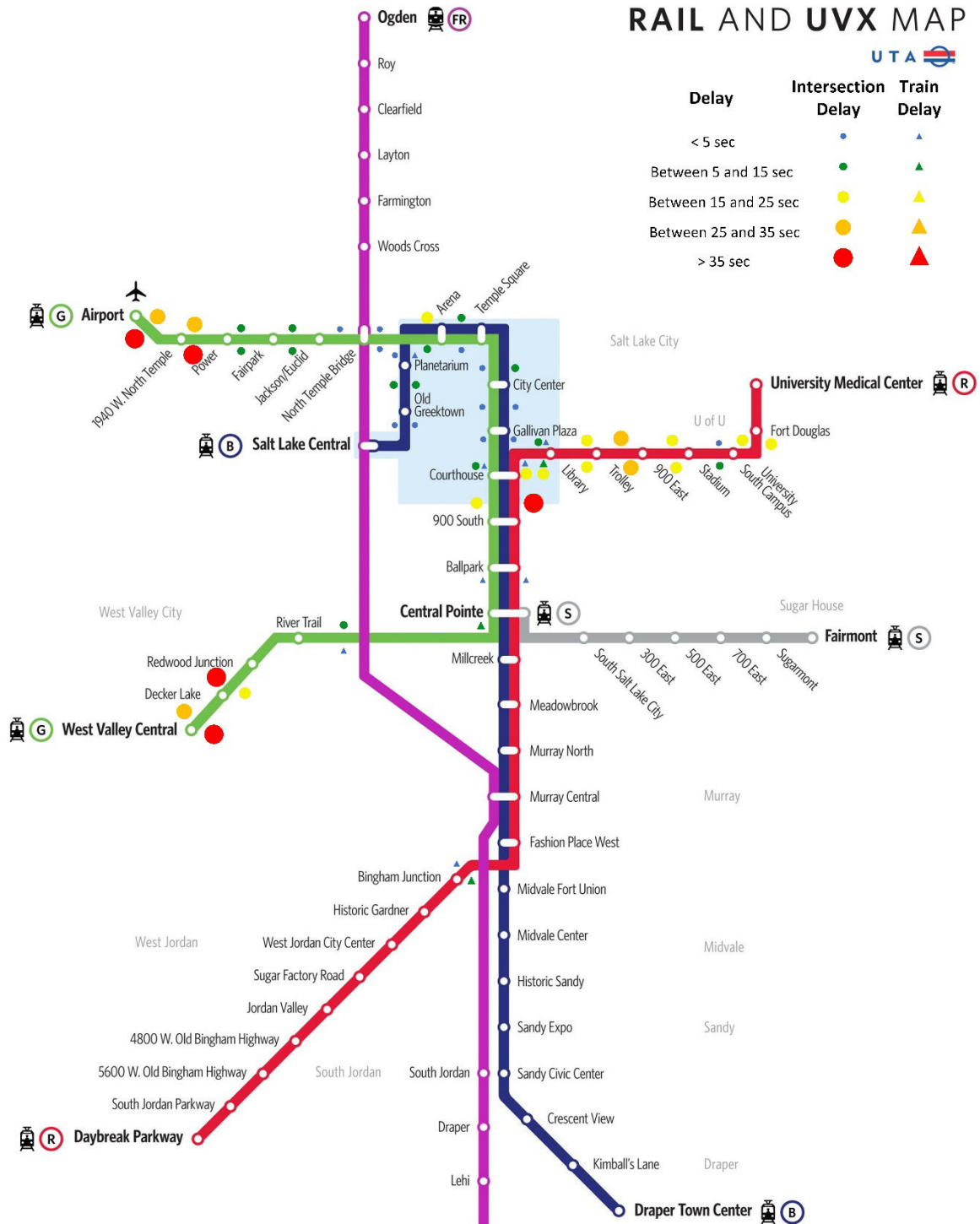

Figure 22 – Simulated Delay Results in Baseline Simulation Scenario

11.7.2 Existing Baseline Simulation Results: Peak Fleet Requirement

The equipment cycles were evaluated to determine the peak fleet requirement for the Existing Baseline simulation. Table 36 shows the breakdown by line and by vehicle type. The Blue Line utilizes SD100 and SD160 vehicles while the Red Line and Green Line utilize S70 vehicles. The combined Peak Fleet Requirement is 26 SD100/SD160 cars and 61 S70 cars, for a total of 29 trains and 87 cars.

Table 36 – Existing Baseline Peak Fleet Requirement

| Future Baseline | Siemens SD100/SD160 | | Siemens S70 | | Combined | |
|-----------------|---------------------|----------|-------------|-----------|-----------|-----------|
| | # Cars | # Trains | # Cars | # Trains | # Cars | # Trains |
| Blue Line | 26 | 8 | 0 | 0 | 26 | 8 |
| Red Line | 0 | 0 | 45 | 13 | 45 | 13 |
| Green Line | 0 | 0 | 16 | 8 | 16 | 8 |
| Combined | 26 | 8 | 61 | 21 | 87 | 29 |

11.8 Strategic Plan Operations Simulation Key Assumptions

The Strategic Plan operations simulation retained all of the assumptions and inputs detailed in the previous sections with the exception of transit signal priority at intersections. As noted in Chapter 6 of the Strategic Plan, transit priorities were improved at many intersections based on evaluation of light rail operational needs and the feasibility of increasing transit priority without materially increasing wait times for other classes of intersection users.

The simulated Strategic Plan scenario retains 15-minute headways on the three existing light rail lines and also schedules new Orange Line service at that frequency. Table 37 shows the Strategic Plan operating plan input with scheduled turn times at each terminal. As is noted in Section 11.5.4, the simulation model uses both scheduled and minimum required train turn times at terminals. During disrupted operations, there may be insufficient time for the Train Operator to walk the train and prepare to depart in the opposite direction, while maintaining schedule. The minimum required turn time in simulation was set to 4 minutes at all terminals while the reverse turn time at non-terminal stations was set as 3 minutes. The table shows that scheduled turn times at all terminals are significantly higher than the 4-minute minimum turn time. The initial Strategic Plan simulation scheduled a 7-minute turn time at West Valley but this provided only 3 minutes of recovery time in the event of lateness. One additional Green Line trains was added to the cycle to increase the scheduled turn time to 22 minutes. With 15-minute headways, both West Valley terminal tracks are used.

Table 37 – Simulated Strategic Plan Scheduled Turn Times

| Line | Terminal | Scheduled Turn Time |
|-------------|---------------------|---------------------|
| Blue Line | Draper Town Center | 11:00 |
| | Airport | 14:00 |
| Red Line | Daybreak Parkway | 15:00 |
| | Medical Center | 11:00 |
| Green Line | West Valley Central | 22:00 |
| | Salt Lake Central | 08:00 |
| Orange Line | Airport | 13:00 |
| | Research Park | 14:00 |

11.9 Strategic Plan Operations Simulation Results

Table 38 shows a breakdown of Strategic Plan simulated performance by lateness threshold and service. Consistent with UTA policy, on-time performance is evaluated at all in-line and terminal locations. The simulation shows an overall on-time performance of 96.4% based on UTA-standard 5-minute lateness tolerances. All trains at all locations are within 10 minutes of their scheduled time in the Strategic Plan simulation despite traffic intersection delays and dwell time variability included in the model.

| Lateness Threshold | 00:00:00 | | 00:03:00 | | 00:04:59 | | 00:10:00 | | All Stops | |
|-------------------------|----------|---------|----------|---------|----------|---------|----------|---------|-----------|---------|
| | Stops | Pct (%) | Stops | Pct (%) | Stops | Pct (%) | Stops | Pct (%) | Stops | Pct (%) |
| Blue Line (701) | 239 | 5.5% | 3260 | 74.63% | 4148 | 95.0% | 4368 | 100% | 4368 | 100% |
| Red Line (703) | 223 | 5.1% | 3657 | 83.19% | 4351 | 99.0% | 4396 | 100% | 4396 | 100% |
| Green Line (704) | 168 | 6.8% | 1690 | 68.59% | 2304 | 93.5% | 2464 | 100% | 2464 | 100% |
| Orange Line | 363 | 14.0% | 2103 | 80.85% | 2531 | 97.3% | 2601 | 100% | 2601 | 100% |
| Combined | 993 | 7.2% | 10710 | 77.45 | 13334 | 96.4% | 13829 | 100% | 13829 | 100% |

Table 39 compares simulated Strategic Plan on-time performance versus the Future Baseline. Overall, system on-time performance at a 5-minute lateness threshold improved from 92.5% to 96.4%. The performance of the Red and Green Lines improved while the new Orange Line shows high on-time performance of 97.3%. The Blue Line, now on a longer route connecting Draper and Salt Lake City with the Airport, shows a slight performance degradation from 96% to 95%.

| Combined Average | TRAX Train Line | | | | Combined Average |
|----------------------------------|-----------------|----------|------------|-------------|------------------|
| | Blue Line | Red Line | Green Line | Orange Line | |
| Future Baseline | 96.0% | 89.1% | 92.6% | | 92.5% |
| Light Rail Strategic Plan | 95.0% | 99.0% | 93.5% | 97.3% | 96.4% |

Strategic Plan simulated time-distance (“string”) charts show both scheduled and simulated train locational traces, allowing a visual assessment of system reliability. Figure 23 shows the simulated results for a morning peak hour with Central Pointe Station on the bottom and University Medical Center on top. The string chart traces the new Red Line route via Ballpark Spur but also shows the Green and Blue Line operation between Central Pointe and Courthouse via Main Street. Figure 23 also shows the new shared University Line operation of the Red and Orange Lines with the latter diverging east of South Campus Station to access the new Research Park Extension. Comparing dark (simulated) traces with light (scheduled) traces highlights the trip-by-trip operating variability reflected in the simulation as a result of intersection delay probabilities and dwell time variability.

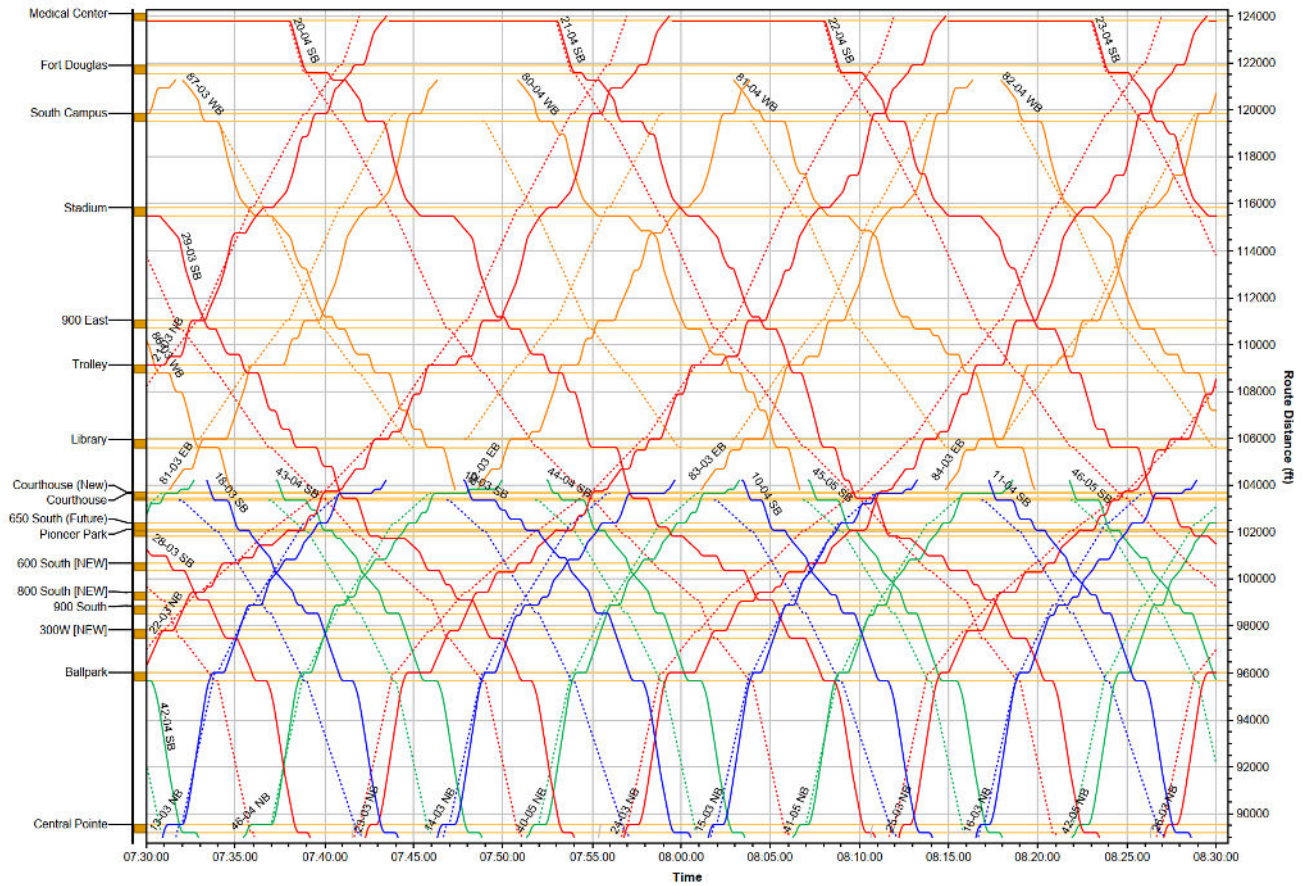

Figure 23 – Simulated Time-Distance String Chart, 7:30 to 8:30 a.m.,
Central Pointe to University Medical Center via Both Main Street and Ballpark Spur

Figure 24 shows another complex time-distance (“string”) chart tracing the path of the new Blue Line route from Central Pointe to North Temple Bridge, along with the new Orange Line from the Main Street/400 South intersection to Salt Lake Central and on to the Airport Line at North Temple Bridge. The chart shows good spacing of the Blue and Orange Line services along North Temple in both directions as well as consistent 5-minute headways where three services share the Trunk Line between Central Pointe and Ballpark Stations.

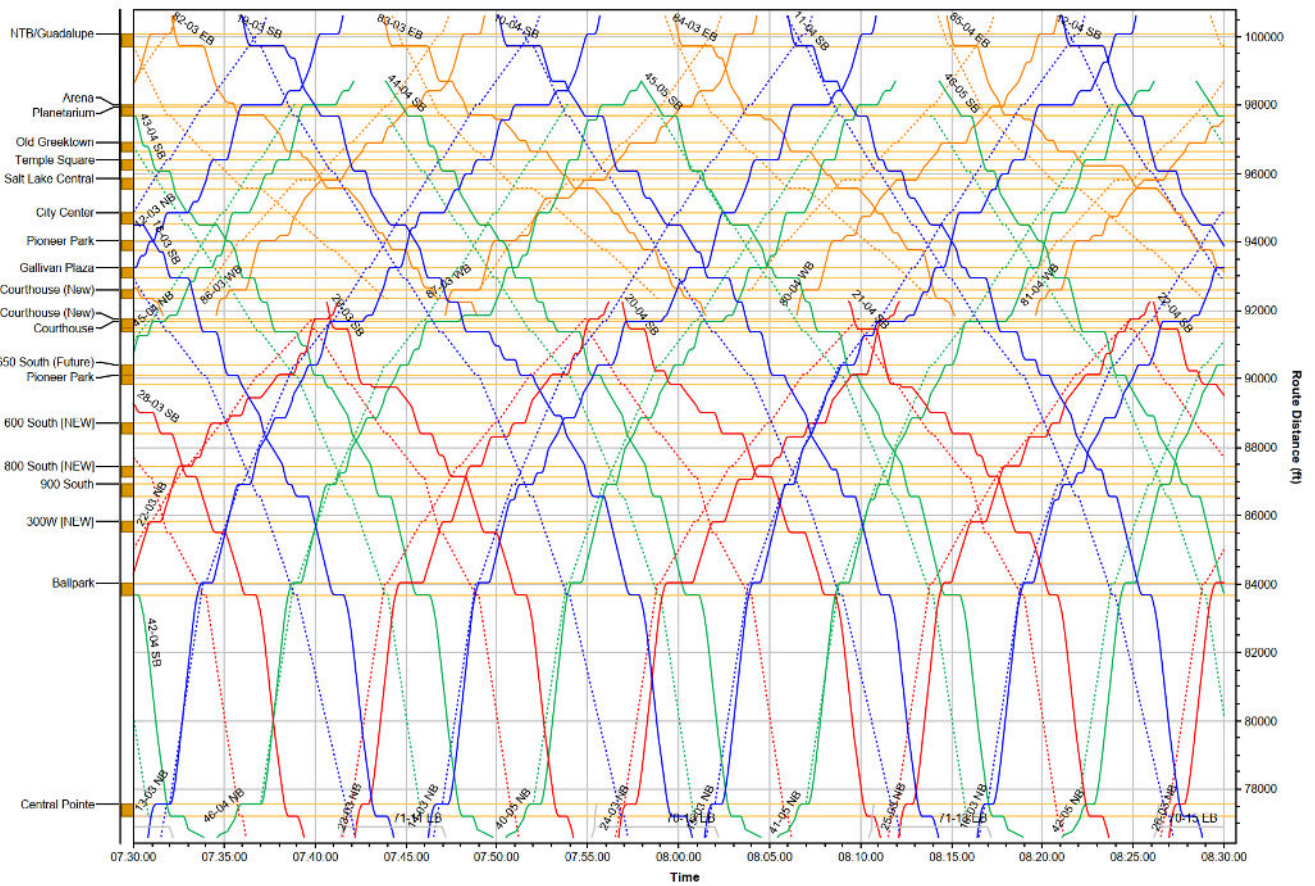

Figure 24 – Simulated Time-Distance String Chart, 7:30 to 8:30 a.m., Central Pointe to North Temple Bridge via Salt Lake Central

Table 40 – Strategic Plan Red Line Northbound Travel Time and Speeds

| Starting Station | Ending Station | Travel Time | Distance (Ft.) | Average Speed (mph) |
|--------------------|--------------------|--------------|----------------|---------------------|
| Ballpark | 300 West [New] | 01:54 | 2216 | 13.24 |
| 300 West [New] | 800 South [New] | 02:03 | 2067 | 11.44 |
| 800 South [New] | 600 South [New] | 02:08 | 1593 | 8.50 |
| 600 South [New] | Pioneer Park (New) | 02:47 | 1804 | 7.35 |
| Pioneer Park (New) | Courthouse (New) | 01:58 | 2070 | 11.92 |
| Courthouse (New) | Library | 03:29 | 2370 | 7.74 |
| Library | Trolley | 03:22 | 3170 | 10.69 |
| Total | | 17:42 | 15290 | 9.82 |

Table 40 shows the average Red Line travel times and speeds for northbound operation from Ballpark Station to Trolley Station via the Ballpark Spur and the expanded light rail network on 400 South. The five new stations shown in the table are notional and do not represent planning level decisions about the location of such new stations. Table 41 shows the same simulation results but for southbound operation between Trolley and Ballpark.

| Table 41 – Strategic Plan Red Line Southbound Travel Time and Speeds | | | | |
|--|--------------------|--------------|----------------|---------------------|
| Starting Station | Ending Station | Travel Time | Distance (Ft.) | Average Speed (mph) |
| Trolley | Library | 02:44 | 3169 | 13.20 |
| Library | Courthouse (New) | 02:09 | 2364 | 12.46 |
| Courthouse (New) | Pioneer Park (New) | 01:48 | 2070 | 13.04 |
| Pioneer Park (New) | 600 South [New] | 02:35 | 1845 | 8.13 |
| 600 South [New] | 800 South [New] | 01:40 | 1594 | 10.83 |
| 800 South [New] | 300 West [New] | 01:43 | 2072 | 13.71 |
| 300 West [New] | Ballpark | 01:37 | 2170 | 15.27 |
| Total | | 14:16 | 15285 | 12.17 |

The Strategic Plan travel time results can be compared with the Future Baseline results shown in Table 42 (northbound) and Table 43 (southbound). While the number of Red Line station stops has increased by two and the Red Line route distance has increased by almost half a mile, the Red Line average speeds are not significantly reduced with the Strategic Plan routing. This is due to avoiding two 90-degree turns north of Ballpark as well as the slow and congested turn at the Main Street/400 South intersection. As planning for the Granary District advances, implementation of four new stations (instead of the five assumed in the Strategic Plan simulations) would allow the new Red Line travel times to match the existing times.

| Table 42 – Future Baseline Red Line Northbound Travel Times and Speeds | | | | |
|--|----------------|----------------|---------------|---------------------|
| Starting Station | Ending Station | Travel Time | Distance (Ft) | Average Speed (mph) |
| Ballpark | 900 South | 0:02:03 | 2877 | 15.92 |
| 900 South | 600 South | 0:03:46 | 3500 | 10.56 |
| 600 South | Courthouse | 0:02:37 | 1265 | 5.50 |
| Courthouse | Library | 0:03:15 | 2308 | 8.07 |
| Library | Trolley | 0:03:13 | 3170 | 11.17 |
| Total | | 0:14:54 | 13120 | 14.67 |

| Table 43 – Future Baseline Red Line Southbound Travel Times and Speeds | | | | |
|--|----------------|----------------|---------------|---------------------|
| Starting Station | Ending Station | Travel Time | Distance (Ft) | Average Speed (mph) |
| Trolley | Library | 0:02:43 | 3169 | 13.28 |
| Library | Courthouse | 0:02:50 | 2271 | 9.11 |
| Courthouse | 600 South | 0:01:29 | 1265 | 9.73 |
| 600 South | 900 South | 0:03:47 | 3535 | 10.62 |
| 900 South | Ballpark | 0:02:04 | 2876 | 15.83 |
| Total | | 0:12:52 | 13116 | 16.98 |

12 Appendix C – Operations and Maintenance Cost Estimating Methodology

12.1 Data Sources

This appendix presents an overview of the Operations and Maintenance (O&M) cost estimating methodology used in the FOLR Study. O&M costs of the various alternatives play a large role in determining the feasibility of new and altered service patterns.

UTA Light Rail Business Unit cost data that were reviewed to develop this methodology included labor, vehicle miles, and traction power data from 2019. The methodology as currently written is valid for FOLR Study alternatives that would implement new Light Rail Transit (LRT) or streetcar lines or extensions and system improvement alternatives.

12.2 Basis of Cost Estimating Methodology

The basis and organization of the methodology uses standard industry cost units and information from UTA's recent O&M costs. Actual labor costs, vehicle data, and traction power costs from 2019 were reviewed to inform unit costs. The available cost information was projected to 2020, then the values were averaged and rounded to appropriate planning level of detail.

12.2.1 Cost Units

LRT O&M cost estimates are based on existing TRAX and streetcar service costs. Major cost drivers include operations labor costs (operators and supervisors), vehicle maintenance (electromechanics and service employees), and Maintenance-of-Way (MOW) including line and signal technicians and traction power costs.

Each of these units is assigned a specific value based on the UTA O&M data from 2019. The cost of each unit is then multiplied by the number of employees required for the service

Other costs and supplies are added to the operations costs, vehicle miles are added to the vehicle maintenance costs, and additional parts and maintenance are added to the MOW costs by project for an annual total cost estimate. These additional costs vary by project and take into consideration hours of service per day and trips per direction per day, which are then multiplied by the traction cost per mile in addition to the LRV cost per mile.

The hours of service per day and trips per direction per day is an estimate that can be calculated based on current service, using existing miles and schedule times, or a more sophisticated rail simulation model. The results of this service plan will include the total vehicle miles, operating hours, and required LRVs to run the service.

12.2.2 Additional Labor Costs

An amount of fringe is added to each labor cost to include employee benefits, training and development, and leave and extra board operators. For this methodology, 47.85% is assumed for fringe to bring the total labor cost to include fully allocated costs.

12.2.3 Traction Power Costs

Traction power costs are developed for the FOLR Study based on the sum of each UTA substation electricity cost and then divided by the annual LRV mileage. The substation electricity cost and LRV mileage data used is from 2019. This methodology assumes a cost per car-mile of \$0.87 for traction power.

12.3 Development of O&M Cost Estimates

A standard spreadsheet was developed that includes all of the categories and unit costs presented in this appendix.

12.3.1 Costs by Unit

The following tables show the costs assumed for each unit for this methodology. Table 44 shows the annual costs of each category of operating employee. Table 45 shows the LRV unit costs assumed, based on 2019 UTA data.

| Table 44 – Labor Unit Cost Assumptions | | |
|--|-------------------------|---|
| Employee Position | Estimated Annual Salary | Fully Allocated Annual Cost (47.85% fringe) |
| Service Employees | \$43,000 | \$63,576 |
| Operators | \$48,000 | \$70,968 |
| Supervisors | \$57,000 | \$84,275 |
| Vehicle Electromechanics | \$57,000 | \$84,275 |
| Line and Signal Techs | \$60,000 | \$88,710 |

| Table 45 – LRV Unit Cost Assumptions | |
|--------------------------------------|---------------|
| Item | Cost Per Mile |
| Traction Power Costs | \$0.87 |
| LRV Maintenance Cost Per Mile | \$1.75 |

12.4 Example of Methodology

The Orange Line concept is presented as an example for using the O&M methodology to estimate the cost of a new service. The Orange Line is a proposed new service that would run between the Salt Lake City International Airport and the University of Utah Medical Center.

| Table 46 – Sample Weekday Orange Line LRV and Traction Power Cost Estimates | | | | | |
|---|--------------------------|---------------------------------|---------------------------------------|-----------------------------|---------------------------|
| Service | Hours of Service Per Day | Trips per direction per weekday | Total Trips per day (both directions) | One-way train miles per day | One-way LRV miles per day |
| Airport to Medical Ctr. | 20 | 77* | 154 | 1822 | 3644 |

| Item | Cost Per Mile | Cost Per Weekday | Weekdays Per Year | Est. Annual TP Costs |
|-------------------------------|---------------|------------------|-------------------|----------------------|
| Traction Power Costs | \$0.87 | \$3,170 | 247 | \$782,982 |
| LRV Maintenance Cost Per Mile | \$1.75 | \$6,376 | 247 | \$1,574,963.39 |

*7 trips in each direction are to/from yard

After the service plan is formed, which estimates the mileage, LRVs needed, and operating hours, this information is used to develop LRV maintenance and traction power cost estimates. Table 46 shows the weekday estimates and Table 47 shows the weekend and holiday estimates. Table 48 shows the total annual LRV maintenance and traction power cost estimates.

Table 47 – Sample Weekend and Holiday Orange Line LRV and Traction Power Cost Estimates

| Service | Hours of Service Per Day | Trips per direction per day (Sat/Sun) | Total Trips per day (both directions) | One-way train miles per day | One-way LRV miles per day |
|-------------------------|--------------------------|---------------------------------------|---------------------------------------|-----------------------------|---------------------------|
| Airport to Medical Ctr. | 20 | 56* | 112 | 1325 | 2650 |

| Item | Cost Per Mile | Cost Per Day (Sat/Sun) | Sat & Sun Per Year | Est. Annual TP Costs |
|-------------------------------|---------------|------------------------|--------------------|----------------------|
| Traction Power Costs | \$0.87 | \$ 2,305 | 105 | \$242,070 |
| LRV Maintenance Cost Per Mile | \$1.75 | \$4,637 | 105 | \$486,922.80 |

*5 trips in each direction are to/from yard

Table 48 – Sample Total Annual LRV and Traction Power Cost Estimates

| Traction Power Costs | Est. Annual Traction Power Costs |
|----------------------|----------------------------------|
| Airport to Medical | \$1,025,052 |

| LRV Maintenance Costs | Est. Annual Vehicle-Mile Costs |
|-----------------------|--------------------------------|
| Airport to Medical | \$2,061,886 |

Table 49 shows the cost estimate by unit for operations, LRV maintenance, and MOW. This includes both labor and other parts and supplies. For the operations costs, the other costs and supplies includes supplies, fuel, computers and equipment. For the LRV maintenance costs, the LRV maintenance cost per mile per year includes parts for 16 additional LRVs (estimated at \$92,000 per vehicle per year). The MOW additional parts and maintenance includes OCS parts, gates, inspections, replacement special trackwork components and fuel.

Table 49 – Sample Orange Line Cost Estimate by Unit

| Operations | No. Additional | Est. Salary | Fully Alloc. Annual cost (47.85% fringe) | Annual Total Costs |
|--|----------------|----------------------------|--|--------------------|
| Operators | 24 | \$48,000 | \$70,968 | \$1,703,232 |
| Supervisors | 4 | \$57,000 | \$84,275 | \$337,098 |
| Other Costs/Supplies | | | | \$75,000 |
| Total | | | | \$2,115,330 |
| LRV Maintenance | No. Additional | Est. Fully Allocated Costs | Fully Alloc. Annual cost (47.85% fringe) | Annual Total Costs |
| Electromechanics | 8 | \$57,000 | \$84,275 | \$674,196 |
| Service Employees | 6 | \$43,000 | \$63,576 | \$381,453 |
| LRV Maintenance Cost Per Mile Per Year | | | | \$2,061,886 |
| Total | | | | \$3,117,535 |
| MOW | No. Additional | Est. Annual Labor Costs | Fully Alloc. Annual Cost (47.85% Fringe) | Annual Total Costs |
| Line and Signal Techs | 3 | \$60,000 | \$88,710 | \$266,130.00 |
| Traction Power Cost Per Year | | | | \$1,025,052 |
| Additional Parts and Maintenance | | | | \$150,000 |
| Total | | | | \$1,441,182 |

The total costs of operations, LRV maintenance, and MOW are then added for a total annual cost, as shown in Table 50.

| Table 50 – Sample Orange Line Cost Estimate Summary | | | | | |
|---|---|-------------|---------------------|-------------|-------------------|
| | Scope of Service | Operations | Vehicle Maintenance | MOW | Total Annual Cost |
| From Medical Center to Airport | 5 a.m.-11 p.m. M-F; 6 a.m.-11 p.m. Sa-Su | \$2,115,330 | \$3,117,535 | \$1,441,182 | \$6,674,047 |

12.5 Light Rail Business Unit Overhead

The Light Rail O&M Cost Model was calibrated to fully allocated Light Rail Business Unit costs by determining the effective UTA overhead rate. Overhead, which is in addition to the fringe benefits multiplier described above, includes all UTA costs not directly associated with delivering service such as:

- + Administration
- + Security
- + Marketing
- + Engineering
- + Capital Development
- + Planning
- + Finance

| Table 51 – 2019 Direct and Total Allocated Light Rail Expense | | | | | | |
|---|-------------|-------------|-------------|-------------|-------------|---------------------|
| | Jan | Feb | Mar | Apr | May | Jun |
| Direct Light Rail Expense | \$4,417,883 | \$4,246,307 | \$4,481,964 | \$4,030,578 | \$4,493,714 | \$3,499,317 |
| Total Allocated Light Rail Expense | \$6,578,689 | \$6,202,071 | \$6,866,962 | \$6,363,367 | \$6,732,932 | \$5,429,821 |
| | Aug | Sep | Oct | Nov | Dec | YTD |
| Direct Light Rail Expense | \$4,402,523 | \$4,652,967 | \$3,842,654 | \$4,054,307 | \$3,325,620 | \$49,951,894 |
| Total Allocated Light Rail Expense | \$6,358,453 | \$6,686,470 | \$6,230,409 | \$6,279,976 | \$5,757,210 | \$76,209,725 |

Table 51 presents monthly direct Light Rail Business Unit expenses (equivalent to the O&M Cost Model predictions) and total allocated Light Rail Business Unit expense, as provided by UTA Finance. The table totals each of these two monthly categories to provide annual totals of about \$50 million for direct expenses and about \$76 million for total allocated expenses. Dividing one figure into the other yields an overhead rate of 52.6%. As a final step in the O&M Cost Model application process, the FOLR Study team multiplied the O&M Cost Model direct cost results by 1.526 in order to compute an “all in” operating cost with business unit and authority overhead costs reflected.

12.6 Light Rail O&M Cost Model Conclusions and Limitations

The planning-level O&M cost estimates developed for the Light Rail Strategic Plan using the methodology presented in this appendix are conceptual in nature and are based on limited current data. These estimates are primarily for comparative purposes to determine the feasibility of the alternatives and establish long-range plan recommendations. As more detailed design and analysis occur during future phases of each project, the planning-level O&M cost estimates should be reviewed and refined.

13 Appendix D – Capital Cost Estimating Methodology

This appendix provides a brief planning-level capital cost estimating methodology used for the Future of Light Rail planning. The capital costs of all improvements included in the Light Rail Strategic Plan were estimated and are included in this report.

Unit costs for use in developing capital costs are presented in the methodology, as well as the basis for unit cost development and the recommended simplified method for computing capital costs for alternatives considered during the project. The methodology addresses both infrastructure and fleet capital costs.

The FOLR planning-level capital cost estimates are conceptual in nature and are based on limited engineering data. These estimates are primarily for comparative purposes to determine the feasibility of the alternatives and establish long-range plan recommendations. As more detailed design and analysis occur during future phases of each project, such as through the TechLink Corridor Study, the planning-level capital cost estimates should be reviewed and refined.

13.1 Methodology Scope

The UTA historical project cost data that were reviewed to develop this methodology were largely limited to new LRT line construction. For this reason, the methodology as currently written is valid for alternatives that would construct new LRT or streetcar lines or extensions. Localized system improvements, such as Union Turnback, were estimated by the FOLR Study team using its library of light rail systems costs.

13.2 Basis of Cost Estimating Methodology

The basis and organization of the estimating methodology is described below. For infrastructure unit costs, the methodology is organized using standard industry cost categories and information regarding UTA's historical project costs. Actual construction cost data from the Mid Jordan, West Valley, and Airport TRAX lines were reviewed to inform the unit costs presented in Table 52. The available cost information was escalated to 2020 from the year of each project completion, then the values were averaged and rounding to appropriate planning level of detail.

For UTA fleet unit costs, three different fleet cost estimating strategies were used, with the recommended fleet capital cost estimates reflecting a blend of the results of all three. These three strategies start with a database showing dozens of examples of the actual costs of purchasing similar types of fleets both domestic and international fleet purchase, covering experience within the industry over the past 20 years. The first approach is an initial examination of recent North American procurements of similar vehicle types, only adjusting to address escalation. The second approach builds up the cost estimates in more detail based on the direct comparison of manufacturing costs while the third approach provides further refinement to the more general second approach. The fleet unit costs developed under each of these three approaches are combined to provide a single capital cost per vehicle, using a straightforward averaging of the three cost estimates.

13.3 Cost Categories

Light Rail Strategic Plan capital costs have been organized into categories consistent with the FTA Standard Cost Categories (SCC). Sub-categories for major project quantities are described later in Section 13.4, Unit Costs. The sub-category unit costs were used with conceptual-level quantities to generate a total estimate for each Strategic Plan element. The major cost categories are:

- + SCC 10: Guideway and Track Elements
- + SCC 20: Stations, Stops, Terminals, Intermodal
- + SCC 30: Support Facilities: Yards Shops Administration Buildings

- + SCC 40: Sitework and Special Conditions
- + SCC 50: Systems
- + SCC 60: Right of Way, Land, Existing Improvements
- + SCC 70: Vehicles
- + SCC 80: Professional Services
- + SCC 90: Unallocated Contingency
- + SCC 100: Finance Charges

Capital costs for the first seven categories (SCC 10–70) were calculated by using unit costs and estimated quantities for each identified sub-category. System-wide costs and allowances were calculated based on route length. A per-track-foot unit cost developed from historical costs was used for such allowances. SCC 80–90 were calculated as a percentage of construction costs, excluding vehicle procurement. SCC 100 is not considered as all Strategic Plan elements are estimated in current year dollars without any consideration of finance charges.

13.4 Unit Costs

Unit costs for this methodology were calculated using historical SCC costs from previous UTA LRT and streetcar projects. No distinction is made between LRT and streetcar for SCC 10–60 because the infrastructure of the two systems is substantially the same.

13.4.1 Quantifiable Infrastructure Components (SCC 10–60)

Detailed quantity calculations were not performed in the planning-level cost estimates. Therefore, unit costs were estimated for the major SCC sub-categories using UTA historical project SCC costs. The quantity units for these sub-category costs are *track-feet* or *route-miles* for linear elements such as guideway systems and *each* for discrete components such as stations or maintenance facilities. Before the cost estimates can be generated, the quantity of each sub-category considered in the methodology was estimated for each alternative. The sub-categories that were quantified for use in the cost estimates and their associated unit costs are listed in Table 52 below.

Some item unit costs are listed as to be determined (TBD). These are items whose cost depended on specific design details and were estimated separately by the project team. In the case of real estate costs, the FOLR Study team relied on the UTA Real Estate Department to provide estimates of probable value.

Table 52 – Sub-categories and Unit Costs Used In Planning-level Cost Estimates

| Sub-Category | Unit | Unit Cost (2020 \$) |
|--|-------------|----------------------------|
| 10 GUIDEWAY AND TRACK ELEMENTS | | |
| 10.01 – Guideway: At-grade Exclusive ROW | Route-miles | 680,000 |
| 10.02 – Guideway: At-grade Semi-exclusive (Cross-traffic) | Route-miles | 1,250,000 |
| 10.03 – Guideway: At-grade in Mixed Traffic | Route-miles | 1,750,000 |
| 10.04 – Guideway: Aerial Structure | Route-feet | 22,000 |
| 10.05 – Guideway: Build Up Fill | Route-miles | 1,500,000 |
| 10.08 – Guideway: Retained Cut or Fill | Route-miles | 1,100,000 |
| 10.09 – Track: Direct Fixation | Route-miles | 4,000,000 |
| 10.10 – Track: Embedded | Route-miles | 5,750,000 |
| 10.11 – Track: Ballasted | Route-miles | 2,650,000 |
| 10.12 – Track: Special (Switches, Turnouts) | Each | 35,000 |
| 10.13 – Track: Vibration and Noise Dampening | Route-miles | 90,000 |
| 20 STATIONS, STOPS, TERMINALS, INTERMODAL | | |
| 20.01 – At-grade Station, Stop, Shelter, Platform | Each | 1,150,000 |
| 20.06 – Automobile Parking Multi-story Structure | Each | 1,500,000 |
| 30 SUPPORT FACILITIES: YARDS, SHOPS, ADMINISTRATION BUILDINGS | | |
| 30.01 – Administration Building: Office, Sales, Storage | Each | TBD |
| 30.03 – Heavy Maintenance Facility | Each | 490,000 |
| 30.05 – Yard and Yard Track | Each | 625,000 |
| 40 SITEWORK AND SPECIAL CONDITIONS | | |
| 40.01 – Demolition, Clearing, Earthwork | Route-miles | 500,000 |
| 40.02 – Site Utilities, Utility Relocation | Route-miles | 2,250,000 |
| 40.03 – Hazardous Materials | Route-miles | 65,000 |
| 40.04 – Environmental Mitigation | Lump sum | TBD |
| 40.05 – Site Structures Including Retaining Walls, Sound Walls | Route-miles | TBD |
| 40.06 – Pedestrian/Bike Access and Accommodation | Lump sum | TBD |
| 40.07 – Roadways, Park-and-Ride Lots | Each | TBD |
| 40.08 – Temporary Facilities and Other Indirect Costs | Lump sum | 8,500,000 |
| 50 SYSTEMS | | |
| 50.01 – Train Control and Signals | Route-miles | 3,100,000 |
| 50.02 – Traffic Signals and Crossing Protection | Route-miles | 600,000 |
| 50.03 – Traction Power Supply: Substation | Route-miles | 1,850,000 |
| 50.04 – Traction Power Distribution: Catenary and Third Rail | Route-miles | 2,500,000 |
| 50.05 – Communication | Route-miles | 1,100,000 |
| 50.06 – Fare Collection System and Equipment | Each | 200,000 |
| 50.07 – Central Control | Each | 100,000 |
| 60 RIGHT OF WAY, LAND, EXISTING IMPROVEMENTS | | |
| 60.01 – Purchase or Lease of Real Estate | Route-miles | TBD |
| 60.02 – Relocation of Existing Households and Businesses | Each | TBD |

13.4.2 Professional Services (SCC 80)

This category includes costs for engineering, administration, and construction management services. These costs were estimated using a percentage of all total direct capital costs except vehicles and right of way (sum of SCC 10–50). Table 53 shows the percentages that are used in this methodology.

| Table 53 – Percentages for Calculation of Professional Services Costs | |
|---|---------------------------------------|
| Professional Services Sub-category | Percentage of Capital Costs SCC 10–50 |
| 80.01 – Preliminary Engineering | 3% |
| 80.02 – Final Design | 7% |
| 80.03 – Project Management for Design and Construction | 5% |
| 80.04 – Construction Administration and Management | 6% |
| 80.05 – Insurance | 3% |
| 80.06 – Legal, Permits, Review Fees | 2% |
| 80.07 – Survey, Testing, Investigation, Inspection | 2% |
| 80.08 – Start-up Costs | 2% |
| Total | 30% |

13.5 Contingency

Contingencies are used in an estimate to account for quantity uncertainty due to the current level of engineering. At the current planning level, contingencies are relatively high. The contingencies to be used for the estimates in this project are described below.

13.5.1 Allocated Contingencies

These contingencies vary by quantity. The allocated contingencies are applied line by line to each of the sub-categories in cost categories 10–70 identified in this methodology. The contingencies vary and were selected based on experience and engineering judgment regarding the potential variability of costs in each sub-category. Table 54 shows the allocated contingencies to be applied to costs in each category.

| Table 54 – Allocated Contingency by Standard Cost Category | |
|--|-----------------------|
| Cost Category | Allocated Contingency |
| SCC 10: Guideway and Track Elements | 30% |
| SCC 20: Stations, Stops, Terminals, Intermodal | 30% |
| SCC 30: Support Facilities: Yards, Shops, Administration Buildings | 30% |
| SCC 40: Sitework and Special Conditions | 30% |
| SCC 50: Systems | 30% |
| SCC 60: Right of Way, Land, Existing Improvements | 30% |
| SCC 70: Vehicles | 10% |

13.5.2 Unallocated Contingencies

The unallocated contingency is entered under SCC 90. It is a flat percentage applied to the overall estimate to account for project unknowns and unquantifiable items at the planning level of analysis. This methodology uses 30% as the unallocated contingency.

13.6 Escalation

No escalation was applied to the capital cost estimates as construction timelines are unknown at present. All construction cost estimates are presented in 2022 dollars and have not been escalated to the anticipated midpoint of project construction or any other future year.

13.7 Development of Vehicles Unit Costs

To determine fleet unit costs, three different fleet cost estimating strategies were used, with the recommended fleet capital cost estimates reflecting a blend of the results of all three. These three strategies start with a database showing dozens of examples of the actual costs of purchasing similar types of fleets both domestic and international fleet purchase, covering experience within the industry over the past 20 years.

13.7.1 Fleet Requirement

The fleet requirement by vehicle type and the projected overall size of the fleet are the two most important inputs to the fleet capital cost estimating process. Unlike many other classes of capital cost estimates, unit costs (e.g., cost per LRV) are highly dependent on the quantity of individual vehicles being purchased at any one time and the eventual overall size of the required fleet to be purchased.

The required size of an operation's fleet also includes a spare factor (or spare margin), defined as the percentage of the overall fleet not required to provide peak service delivery. For example, if a service plan required 45 train sets to handle peak period service, a spare factor of 10% would result in an overall fleet size of 50 – the 45 required to provide the peak period service and 5 extras to be used in case of breakdown, servicing, etc. Although there are variations within the industry with respect to how the spare margin is computed, UTA consistently defines the spare margin as a percentage of total fleet. The FOLR Study considers any standby or “protect” trains to be spares rather than part of the fleet required for peak service delivery. As with the methodology for computing the size of the spare factor, there are differences across the industry. North American light rail and streetcar spare factors, which range from 10 to 50%, depend on:

- + Reliability of the specific vehicle type, with more reliable vehicles requiring a lower spare factor
- + Age of the specific vehicle type, with some newly-opened rail systems operating on a provisional basis with spare factors of less than 10% until initial heavy maintenance work is required
- + Number of in-service vehicles of the specific vehicle type, with larger quantities requiring a lower spare factor

13.7.2 Data Sources

The project team employs a market-based methodology for estimating rail vehicle capital costs, relying on its proprietary vehicle pricing database. If appropriate data are not available for a specific fleet procurement, external databases including the American Public Transportation Association (APTA) equipment directory are used. Labor costs for vehicle engineering, project management and production cost elements of fleet capital costs are typically estimated using standard industry rates for fleet manufacturers.

13.7.3 Labor and Material Escalation

Escalation is added to the historical vehicle prices using an economic price adjustment formula that considers material, labor, fixed costs and exchange rate impacts using data from the U.S. Bureau of Labor Statistics (BLS) and historical currency exchange data from Olsen and Associates (OANDA). Material indices are shown below in Figure 25 and Figure 26. Table 55 displays escalation values for the last 22 years; the 1995 index value of 100 has increased to 147.55 in 2017, or a compounded annual increase of about 1.8 %. Currency (exchange rate) adjustments are required for all fleet acquisitions, though the percentage of the total fleet cost subject to adjustments will vary.

Although some of the UTA’s fleet acquisitions will be subject to federal “Buy America” requirements (because federal funding is part of the fleet acquisition), currency exchange adjustments are required for these compliant purchases because some vehicle components are purchased from non-U.S. markets. About 30% of “Buy America” compliant fleet costs are subject to current adjustments; higher percentages apply to fleet costs not subject to FTA “Buy America” requirements.

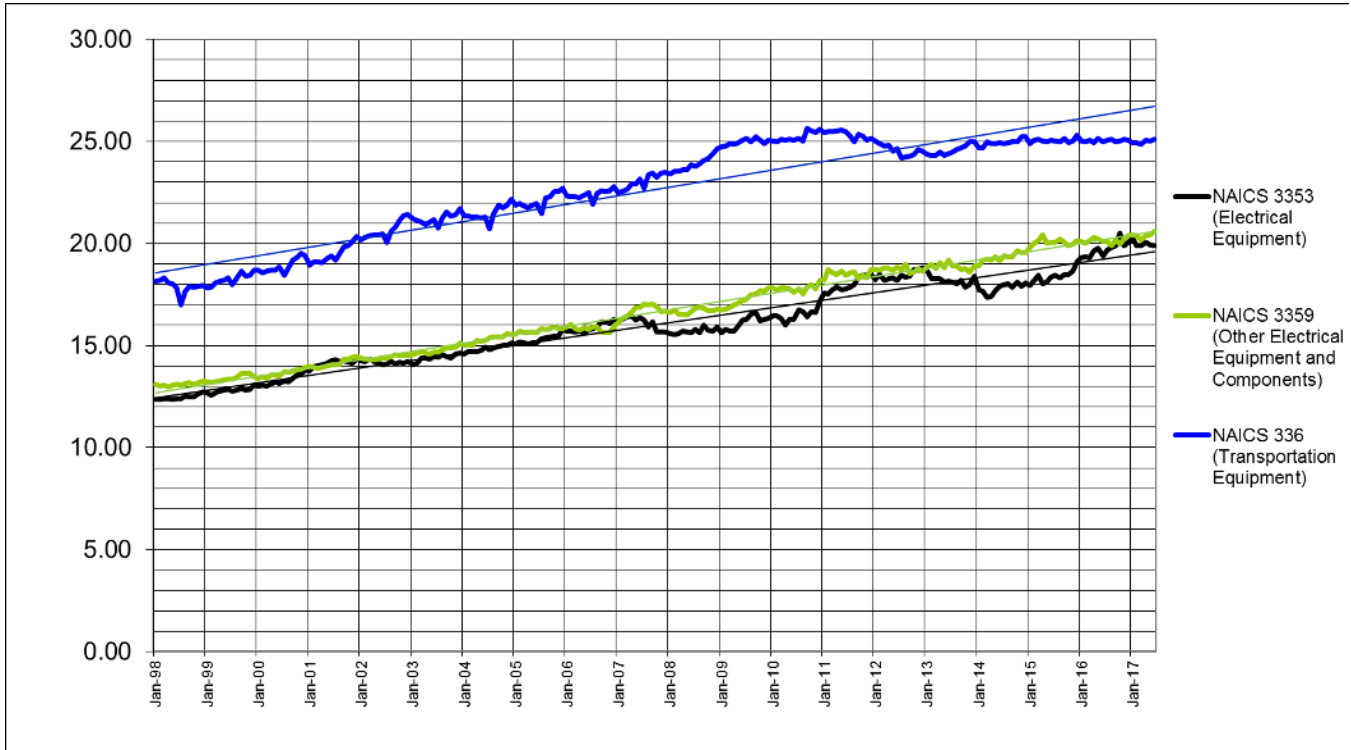

Figure 25- NAICS Indices for Electrical & Transportation Equipment

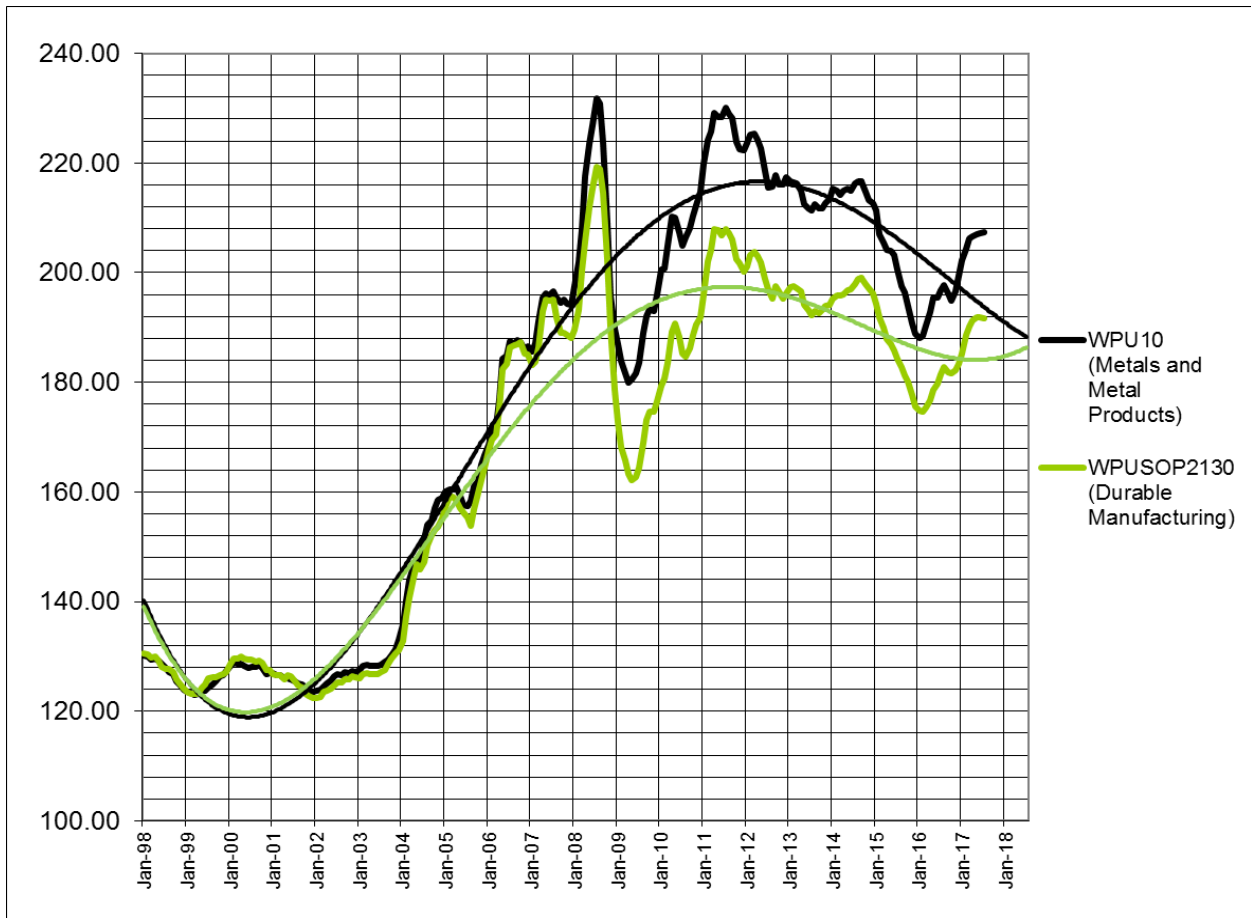

Figure 26 – WPU Indices for Metals & Manufacturing

| Table 55 – Typical Vehicle Labor and Material Escalation 1995-2020 | | | | | | |
|--|------------|------------|-----------|----------|------------|----------|
| Index | Labor | | | Material | | Summary: |
| | NAICS 3353 | NAICS 3359 | NAICS 336 | WPU 10 | WPUSOP2130 | |
| Percentage of Category | 41.5% | 8.5% | 50.0% | 50.0% | 50.0% | |
| Overall Percentage | 16.6% | 3.4% | 20.0% | 25.0% | 25.0% | |
| 1995 | 11.02 | 11.86 | 17.21 | 134.50 | 135.60 | 73.20 |
| 1996 | 11.47 | 12.45 | 17.66 | 131.00 | 131.30 | 71.43 |
| 1997 | 12.10 | 12.90 | 17.99 | 131.80 | 132.80 | 72.20 |
| 1998 | 12.46 | 13.10 | 17.90 | 127.77 | 127.99 | 70.03 |
| 1999 | 12.80 | 13.39 | 18.24 | 124.63 | 125.09 | 68.66 |
| 2000 | 13.28 | 13.64 | 18.89 | 128.04 | 129.03 | 70.72 |
| 2001 | 14.14 | 14.13 | 19.48 | 125.39 | 125.13 | 69.35 |
| 2002 | 14.18 | 14.42 | 20.63 | 125.93 | 124.67 | 69.62 |
| 2003 | 14.40 | 14.76 | 21.22 | 129.23 | 127.88 | 71.42 |
| 2004 | 14.85 | 15.29 | 21.48 | 149.63 | 146.61 | 81.34 |
| 2005 | 15.30 | 15.74 | 22.08 | 160.80 | 158.31 | 87.27 |
| 2006 | 15.89 | 15.83 | 22.41 | 181.63 | 180.54 | 98.20 |
| 2007 | 16.11 | 16.72 | 23.03 | 193.47 | 189.80 | 103.67 |
| 2008 | 15.71 | 16.69 | 23.88 | 213.03 | 203.27 | 112.02 |
| 2009 | 16.11 | 17.26 | 24.98 | 186.81 | 168.93 | 97.19 |
| 2010 | 16.51 | 17.82 | 25.23 | 207.60 | 186.58 | 106.93 |
| 2011 | 17.99 | 18.51 | 25.34 | 225.94 | 204.18 | 116.21 |
| 2012 | 18.43 | 18.73 | 24.57 | 219.85 | 199.13 | 113.35 |
| 2013 | 18.20 | 18.87 | 24.56 | 213.50 | 194.58 | 110.59 |
| 2014 | 17.81 | 19.32 | 24.95 | 215.03 | 196.99 | 111.61 |
| 2015 | 18.38 | 20.07 | 25.05 | 200.26 | 184.88 | 105.03 |
| 2016 | 19.72 | 20.14 | 25.06 | 194.35 | 179.43 | 102.42 |
| 2017 | 20.22 | 20.54 | 25.36 | 207.80 | 191.68 | 109.00 |
| 2018 | 20.73 | 21.40 | 26.31 | 223.60 | 206.30 | 116.90 |
| 2019 | 20.10 | 21.64 | 27.14 | 221.26 | 202.48 | 115.43 |
| 2020 | 20.56 | 21.23 | 27.96 | 218.58 | 195.45 | 113.23 |

Source: U.S. Bureau of Labor Statistics (BLS)

13.7.4 Currency Escalation

When escalating historical car prices to the present, a foreign exchange (currency escalation) factor must be included. For the purpose of UTA fleet capital costs, it is assumed that the vehicles are subject to FTA “Buy America” requirements and that foreign content, to which the foreign exchange factor applies, constitute 30% of overall fleet cost. The current FTA “Buy America” regulations require that all rolling stock purchased with federal (FTA) funding have a minimum domestic content of 70%. Therefore, a maximum of 30% is international content and this “worst case” percentage is subject to currency escalation. Four different currencies are typically considered in this analysis (Euro, Canadian Dollar, Japanese Yen and Korean Won). These represent the home countries of the most likely bidders for UTA fleet additions and replacements.

Suppliers based in China have recently started to bid on projects in North America. However, because of their recent entry into the market and also because the Chinese Yuan has tended to closely track the dollar, the Yuan is not typically considered in this analysis. Currency exchange rate impacts on the historical prices vary depending upon the year the contract was originally signed, and the currency involved. Table 56 displays these currency escalation factors, with the German Mark used to establish a benchmark for the Euro prior to 1998.

Table 56 – Currency Escalation Factors 1995-2020

| | Euro Index Average for Year | Escalation to 2020 | Canadian Dollar Index Average for Year | Escalation to 2020 | Japanese Yen Index Average for Year | Escalation to 2020 | Korean Won Index Average for Year | Escalation to 2020 |
|-------------|-----------------------------|--------------------|--|--------------------|-------------------------------------|--------------------|-----------------------------------|--------------------|
| 1995 (Avg.) | 0.53105 | -69.48% | 1.37258 | -0.30% | 94.07659 | -14.55% | 771.36667 | -59.53% |
| 1996 (Avg.) | 0.61274 | -46.89% | 1.36381 | -0.95% | 108.82624 | 0.97% | 804.83238 | -52.89% |
| 1997 (Avg.) | 0.82637 | -8.92% | 1.38488 | 0.59% | 121.04493 | 10.97% | 953.99904 | -28.99% |
| 1998 (Avg.) | 0.85388 | -5.41% | 1.48363 | 7.20% | 130.88462 | 17.66% | 1402.11164 | 12.24% |
| 1999 (Avg.) | 0.93917 | 4.17% | 1.48586 | 7.34% | 113.80969 | 5.31% | 1190.12959 | -3.40% |
| 2000 (Avg.) | 1.08500 | 17.05% | 1.48526 | 7.31% | 107.86045 | 0.09% | 1131.15811 | -8.79% |
| 2001 (Avg.) | 1.11691 | 19.42% | 1.54904 | 11.12% | 121.55551 | 11.34% | 1291.49918 | 4.72% |
| 2002 (Avg.) | 1.06106 | 15.17% | 1.57021 | 12.32% | 125.21937 | 13.94% | 1249.79397 | 1.54% |
| 2003 (Avg.) | 0.88540 | -1.65% | 1.40697 | 2.15% | 115.97995 | 7.08% | 1194.54247 | -3.01% |
| 2004 (Avg.) | 0.80510 | -11.79% | 1.30151 | -5.78% | 108.17451 | 0.38% | 1150.90628 | -6.92% |
| 2005 (Avg.) | 0.80453 | -11.87% | 1.21173 | -13.62% | 110.12445 | 2.14% | 1027.59332 | -19.75% |
| 2006 (Avg.) | 0.79703 | -12.92% | 1.34610 | -2.28% | 116.33664 | 7.37% | 969.90155 | -26.87% |
| 2007 (Avg.) | 0.73082 | -23.16% | 1.07440 | -28.14% | 117.81453 | 8.53% | 935.26976 | -31.57% |
| 2008 (Avg.) | 0.66744 | -34.85% | 1.03482 | -33.04% | 105.30564 | -2.34% | 1046.94259 | -17.54% |
| 2009 (Avg.) | 0.71920 | -25.15% | 1.14130 | -20.63% | 93.63000 | -15.10% | 1273.70000 | 3.39% |
| 2010 (Avg.) | 0.75510 | -19.20% | 1.03040 | -33.61% | 87.82000 | -22.71% | 1153.54000 | -6.68% |
| 2011 (Avg.) | 0.71780 | -25.39% | 0.98830 | -39.31% | 79.73000 | -35.16% | 1104.95000 | -11.37% |
| 2012 (Avg.) | 0.77810 | -15.67% | 0.99960 | -37.73% | 79.78000 | -35.08% | 1123.07000 | -9.57% |
| 2013 (Avg.) | 0.75320 | -19.50% | 1.02980 | -33.69% | 97.58000 | -10.44% | 1090.42000 | -12.85% |
| 2014 (Avg.) | 0.75350 | -19.45% | 1.16430 | -18.25% | 121.42000 | 11.25% | 1050.63000 | -17.12% |
| 2015 (Avg.) | 0.89770 | -0.26% | 1.25010 | -10.13% | 121.00000 | 10.94% | 1113.78000 | -10.48% |
| 2016 (Avg.) | 0.89060 | -1.06% | 1.29575 | -6.25% | 106.00600 | -1.66% | 1144.48000 | -7.52% |
| 2017 (Avg.) | 0.92944 | 3.16% | 1.33517 | -3.11% | 112.63918 | 4.33% | 1099.38430 | -11.93% |
| 2018 (Avg.) | 0.87014 | -3.44% | 1.31428 | -4.75% | 112.16429 | 3.92% | 1123.38098 | -9.54% |
| 2019 (Avg.) | 0.89306 | -0.78% | 1.32676 | -3.77% | 109.01196 | 1.14% | 1166.02960 | -5.53% |
| 2020 (Avg.) | 0.91126 | 1.23% | 1.36600 | -0.79% | 108.34792 | 0.54% | 1153.75344 | -6.66% |

13.7.5 Required Level of Detail

The vehicle capital cost estimates are to be developed at a level of detail appropriate for a long-range planning study. For the FOLR Study, vehicle capital cost estimates include all-in vehicle cost (e.g., the escalated average of recent comparable procurements as detailed below as Approach 1) rather than the considerably more detailed “built-up” approach more appropriate when evaluating actual vehicle supplier proposals.

13.7.6 Vehicle Capital Cost Estimating Methodology

Three separate approaches are utilized to develop an integrated, market-based unit cost for additions and replacements to the UTA fleet. Approach 1 is an initial straightforward examination of recent North American procurements of similar vehicle types, only adjusting to address escalation. Approach 2 builds up the cost estimates in more detail based on the direct comparison of manufacturing costs while Approach 3 provides further refinement to the more general Approach 2. As described below, the capital cost estimates developed under each of these three approaches are combined to provide a single capital cost per vehicle, using a straightforward averaging of the three cost estimates.

The three vehicle cost estimating approaches which are discussed further below use as their basis all available domestic and, where applicable, international vehicle prices for similar types of vehicles. Depending on the specific vehicle type being considered, this list has from 10 to 50 individual vehicle contract results to draw upon, spanning the last 20 years.

When historical data are available for similar types of LRVs, Approaches 1 and 2 are employed. For relatively unique vehicles such as the 162-foot LRVs not presently in service in the U.S. market, all three approaches are used with a greater emphasis placed on the more detailed price build-ups (Approaches 2 and 3).

Approach 1: Escalated Average of Recent Procurements: This approach is based on the average per vehicle cost of recent vehicle procurements, adjusted for inflation only. Included within this analysis are different vehicles under review in the FOLR Study, all of which have a variety of technical attributes such as vehicle length, seating capacity, maximum design speed and passenger amenities. This results in an order-of-magnitude cost estimate for the vehicles.

Approach 2: Contract Cost Build-Up Based on Recent Procurements: This approach is based on a cost build-up analysis using the average estimated base manufacturing cost of each vehicle type from the same data sources used in Approach 1. The base manufacturing cost is the estimated recurring labor and material costs required to produce each vehicle.

The base manufacturing cost is calculated by backing out from each of the recent procurements the following estimated program-related non-recurring costs:

- + profit
- + general and administration (G&A)
- + engineering
- + production-related “learning curve” costs

Profit and G&A percentages are set at the same rate for all of the procurements in order to normalize that portion of the fleet capital cost estimates while engineering and learning curve costs vary as discussed below.

Engineering is considered principally a fixed cost related to the complexity of the vehicle. In certain cases, the engineering cost of the procurement is known from internal documents. All other engineering costs are estimated based on the size of the procurement and the complexity and uniqueness of the design.

The first production vehicles will require more hours to build and assemble than later vehicles that are part of the same contract. These “learning curve” cost impacts affect the first five to 20 (or more) vehicles depending on the builder, the complexity and other factors. The estimated base manufacturing costs from earlier procurements are averaged in order to provide the base manufacturing cost used in a contract cost build-up for the vehicles. After calculating the base manufacturing cost, all estimated program-related costs including engineering (detailed in Table 57), production set-up/tooling costs, vehicle supplier profit, G&A expenses and learning curve impacts are then added to yield an estimated contract cost per vehicle.

Approach 3: Contract Cost Build-Up Based on the Recent Procurement of a Near-Compatible Vehicle: This approach is similar to Approach 2 in that a base manufacturing cost is calculated and then used as the basis for a contract cost (bid price) build-up. While Approach 2 uses a base manufacturing, cost averaged over several projects, Approach 3 uses the specific manufacturing cost from a vehicle that is expected to be close or near-compatible to the proposed vehicles. The labor and material costs for any known design differences are added during the cost build-up. When the technical details of the proposed vehicles have only been defined at a conceptual level, no costs for specific technical variations will be included.

13.7.7 Non-Recurring Engineering Costs

The planned delivery schedule of the vehicles is taken into consideration when developing the non-recurring engineering costs, which are based on an estimated project schedule and on the vehicle development’s complexity. For a specific

vehicle that has a long delivery schedule due to engineering and manufacturing complexities, the project management, testing and engineering support costs will be greater. Manpower loading (labor hours) by job title for this schedule are developed. Complex projects with significant amounts of development and documentation will require heavier loading than simpler projects that are closer to “off-the-shelf” production. Standard industry labor rates are used for each job title, as shown in Table 57. The estimated engineering costs are applied to the estimated rolling stock unit prices developed using Approach 2 and Approach 3.

| Table 57 – Assumed Labor Rates by Title and Year of Production | | | | | | |
|---|-------------------|------------------------|-------------------------|------------------------------------|-------------------------------------|--------------------|
| Title | Shop Labor | Project Manager | Project Engineer | Field Electronic Technician | Software and System Engineer | Engineering |
| 2020 | \$90.00 | \$175.00 | \$160.00 | \$90.00 | \$155.00 | \$140.00 |
| 2021 | \$92.70 | \$180.25 | \$164.80 | \$92.70 | \$159.65 | \$144.20 |
| 2022 | \$95.48 | \$185.66 | \$169.74 | \$95.48 | \$164.44 | \$148.53 |
| 2023 | \$98.35 | \$191.23 | \$174.84 | \$98.35 | \$169.37 | \$152.98 |
| 2024 | \$101.30 | \$196.96 | \$180.08 | \$101.30 | \$174.45 | \$157.57 |
| 2025 | \$104.33 | \$202.87 | \$185.48 | \$104.33 | \$179.69 | \$162.30 |
| 2026 | \$107.46 | \$208.96 | \$191.05 | \$107.46 | \$185.08 | \$167.17 |
| 2027 | \$110.69 | \$215.23 | \$196.78 | \$110.69 | \$190.63 | \$172.18 |
| 2028 | \$114.01 | \$221.68 | \$202.68 | \$114.01 | \$196.35 | \$177.35 |
| 2029 | \$117.43 | \$228.34 | \$208.76 | \$117.43 | \$202.24 | \$182.67 |
| 2030 | \$120.95 | \$235.19 | \$215.03 | \$120.95 | \$208.31 | \$188.15 |
| 2031 | \$124.58 | \$242.24 | \$221.48 | \$124.58 | \$214.56 | \$193.79 |
| 2032 | \$128.32 | \$249.51 | \$228.12 | \$128.32 | \$220.99 | \$199.61 |
| Averages | \$97.03 | \$188.66 | \$172.49 | \$97.03 | \$167.10 | \$150.93 |
| Production Average Base (2019-2020) | \$96.91 | \$188.44 | \$172.29 | \$96.91 | \$166.91 | \$150.75 |

13.7.8 Development of Vehicle Contract Cost Estimate

The three approaches outlined above are used to create an interim estimated vehicle contract cost. To create a single integrated vehicle contract cost estimate, the estimated costs from each approach listed above are typically averaged together at equal weighting to develop the contract cost estimate for each vehicle type. Greater weighting to Approach 2 and especially to Approach 3 is applied when the vehicle design in question is considerably different than what has recently been produced by any vehicle supplier. Approach 3 is dropped entirely early in the vehicle capital cost estimating process if little to no technical details of the vehicle configuration are known. For the UTA Future of Light Rail estimates, most of the estimates focused on Approaches 1 and 2.

A risk factor is then applied based on the complexity of the design and anticipated market conditions, among other factors. This factor tends to be higher for estimates early in the procurement cycle. As such, budgetary type capital cost estimates tend to have more margin than estimates that are based off of detailed technical specifications that are provided close to the time of contract award. This provides protection against changes in quantity or relatively minor technical changes that often occur during the planning and specification process. For the FOLR Study estimates, a range of plus 10% and minus 5% is applied. Typically when the technical specifications have not yet been defined and the fleet capital cost estimates are based only on functional requirements, the plus 10% risk factor is added due to the uncertainty in the design as well as the timing of the procurement. The lower end of the range is only used when the market is on a clear downward trend from a pricing high.

13.7.9 Training, Spare Parts and Other Ancillary Costs

In addition to estimating vehicle capital costs by the procedure outlined above, related ancillary costs are added to the estimated vehicle unit prices. These include:

- + Bonding
- + Training and Manuals
- + Spare Parts, Special Tools and Test Equipment

Bonding prices are estimated at a percentage of the base vehicle capital cost estimate. The percentage is developed from a review of recent peer public agency procurements.

Training and manual costs are determined by estimating the hours needed for both groups of activities and then adding necessary material costs for the documentation and deliverables required.

Spare parts, special tools and test equipment prices are developed from the project team’s component and equipment price database.

Table 58 shows the recommended Future of Light Rail vehicle unit costs, defined in terms of present 81-foot car lengths and in terms of potential 108-foot and 162-foot car lengths. The longer car lengths are based on adjustments to the 81-foot car unit costs in terms of propulsion system/trucks, doors, HVAC, carbody and Non-Recurring Engineering.

| Table 58 – UTA Light Rail Vehicle Unit Capital Costs | | | |
|---|-------------------|-----------------|-----------------|
| Price Comparisons | 81' Car | 162' Car | 108' Car |
| Assumed Fleet Size | 60 | 30 | 45 |
| Base Price \$70 | \$3,987,292 | \$3,987,292 | \$3,987,292 |
| Propulsion/Trucks | \$0 | \$1,641,636 | \$695,818 |
| Doors | \$0 | \$138,647 | \$69,323 |
| HVAC | \$0 | \$214,981 | \$107,491 |
| Carbody/Others | \$0 | \$656,181 | \$218,727 |
| Non-Recurring Engineering | \$0 | \$1,126,634 | \$300,436 |
| Total Unit Cost | \$3,987,292 | \$7,765,371 | \$5,379,087 |
| Fleet | \$239,237,507 | \$232,961,126 | \$242,058,895 |
| Total/Ft | \$49,226 | \$47,934 | \$49,806 |
| | <i>Difference</i> | -3% | 1% |

13.7.10 Development of Planning-level Estimates

The steps for developing each cost estimate for the Light Rail Strategic Plan are shown below. A standard spreadsheet was developed that includes all of the categories and unit costs discussed in the Basis of Cost Estimating Methodology and Development of Vehicles Unit Costs sections. The spreadsheet is used to ensure a standard approach and boost efficiency in the estimate development.

- + Estimate quantities in each sub-category in Table 52 using the planning-level alternative description
- + Multiply quantities by unit costs developed previously
- + Apply allocated contingency to each computed cost per Table 54
- + Determine YoE and escalate costs and allocated contingency using 3.5% per year
- + Sum costs to determine subtotal

- + Determine professional services costs as a percentage of subtotal per Table 53
- + Determine right of way, land, and existing improvements costs
- + Determine vehicles costs, including appropriate provisions for spare margin and for spare parts/training
- + Apply unallocated contingency to subtotal and professional services costs
- + Develop grand total for planning-level capital cost estimate

14 Appendix E – Granary District, Ballpark Spur and 400 South Extensions Concept Design

Study team member HDR developed a concept design for the Granary District Ballpark Spur and 400 South Extension based on a conceptual track layout proposed by the Light Rail Business Unit. The design features two-track street or median operation throughout. Although highly conceptual in nature, a total of five new light rail stations are included in the concept design; these are subject to refinement as UTA's TechLink Study gets underway.

Figure 27 provides an overview of the initial design concept, which features a connection on 400 West to the existing Blue Line's approach to Salt Lake Central from the north. During the Strategic Plan development process, this was modified to approach Salt Lake Central from the south, via 400 South and 600 West. Still later, the segment on 400 West adjacent to Pioneer Park was added back to the Strategic Plan's recommendations as a non-revenue connector.

Figure 28 shows the Granary District Ballpark Spur Extension and its junction with the existing Trunk Line at Ballpark Station. A single track connection to the Ballpark Spur (used for non-revenue operation only) exists today but will be enhanced as a two-track flat junction as part of these improvements. The Ballpark Spur Extension concept design in the vicinity of 700 South is shown in Figure 29. The Ballpark Spur Extension concept design and its half grand union junction at 400 West and 400 South is shown in Figure 30. The segment on the west side of Pioneer Park was subsequently replaced with proposed revenue trackage to 400 West/600 South, approaching Salt Lake Central from the south. Later, the segment on the west side of Pioneer Park was restored to the plan, but in the form of a two-block non-revenue connector between 400 West/400 South and 400 West/200 South. Half grand unions are included at both ends of the non-revenue connector.

Figure 31 shows the 400 South Extension concept design and its connection with the University Line and Main Street Trunk Line. It highlights the Courthouse grand union, an expansion from the half grand union presently in service at this location. The new center island platform on 400 South labeled "Courthouse" might be more appropriately designated as "Courthouse West" to avoid confusion with the current station of same name on Main Street.

Figure 32 provides concept design detail on the full grand union and half grand union track layouts. The full grand union layout is applicable to the 400 South/Main Street intersection while the half grand unions are applicable to the other proposed junctions on the Ballpark Spur and 400 South. Note that the full grand union has implications in terms of how close the existing Courthouse (with possible northward extension) and proposed Courthouse West station platforms can be located to each other. In follow-on work, UTA should evaluate the trade-offs of shorter connecting distances between these two sets of platforms versus loss of operational flexibility should some of the track connections shown in Figure 32 be omitted from the final design.

Figure 33 displays an overview of planning level property acquisition requirements for the Granary District Ballpark Spur and 400 South Extensions. These are shown in greater detail in Figure 34 and Figure 35.

Figure 34 displays real estate issues with the southern portion of the Granary District Ballpark Spur and 400 South Extensions concept design. It highlights potential required property acquisition just north of Ballpark Station needed to support a full two-track connection to the Ballpark Spur. Figure 35 displays planning level real estate issues related to the Granary District Ballpark Spur and 400 South Extensions, highlighting potential 900 South and 800 South property acquisitions.

Finally, a revised connection from the Ballpark Spur to Salt Lake Central was developed to provide a more direct approach to Salt Lake Central via 400 South/600 West. This allows through running operation, such as interlining of the proposed Orange Line with the existing Green Line or proposed Strategic Plan Blue Line operation. Because of the 400

South viaduct approach crossing the FrontRunner and Union Pacific tracks, there are limited options at this location. The FOLR Study Team evaluated three alignment concepts at this location: all-north, all-south and straddling (one light rail track on each side of the viaduct). Each has important implications with respect to:

- + Light rail directional flows integrating with the flow of other modes
- + Operating speeds
- + Property taking, including considerations of which required properties are publicly owned versus privately owned
- + Ability to access both Salt Lake Central station tracks from both mainline tracks for turnback operations
- + Ability to support connectivity to new (replacement) tail tracks south of Salt Lake Central station for turnback operations when the future Orange Line service is operating through the station and a second service (Blue Line at present, Green Line in the future as recommended by the Strategic Plan) turns back to the north

The \$123.9 million total estimated cost (in 2022 dollars) of the TRAX improvements in the Granary District, including Ballpark Spur and 400 South TRAX connecting the University Line at Main Street with Salt Lake Central, is shown in Table 59. The cost is dominated by nearly equal shares for guideway (including track), the five assumed new stations and rail systems. Costs for sitework and for Right of Way acquisition also contribute to the overall cost. The total estimated cost of the project includes 30% allocated contingency for each of the standard FTA cost categories as well as 30% unallocated contingency. The estimate also includes professional services and other “soft” costs using standard cost factors.

| Table 59 – Granary District, Ballpark Spur and 400 South Extensions Capital Cost Estimate | | | | | |
|--|--|-----------------|-------------|------------------|----------------------|
| 10 GUIDEWAY AND TRACK ELEMENTS | | | | | |
| Sub Category | Item | Quantity | Unit | Unit Cost | Total Cost |
| 10.01 | Guideway: At-grade Exclusive ROW | 0.55 | Route-miles | \$ 680,000 | \$ 374,000 |
| 10.03 | Guideway: At-grade in Mixed Traffic | 1.95 | Route-miles | \$ 1,750,000 | \$ 3,412,500 |
| 10.10 | Track: Embedded | 1.95 | Route-miles | \$ 5,750,000 | \$ 11,212,500 |
| 10.11 | Track: Ballasted | 0.55 | Route-miles | \$ 2,650,000 | \$ 1,457,500 |
| 10.12 | Track: Special - New Half Grand Union | 2 | Each | \$ 350,000 | \$ 700,000 |
| 10.12 | Track: Special - Convert Existing Half to Full Grand Union | 1 | Each | \$ 450,000 | \$ 450,000 |
| 10.12 | Track: Special - No. 8 Turnout | 4 | Each | \$ 150,000 | \$ 600,000 |
| 10.12 | Track: Special - Double Junction | 1 | Each | \$ 250,000 | \$ 250,000 |
| 10 SUBTOTAL | | | | | \$ 18,456,500 |
| 10 ALLOCATED CONTINGENCY | | | | 30% | \$ 5,536,950 |
| 10 TOTAL | | | | | \$ 25,190,000 |
| 20 STATIONS, SHOPS, TERMINALS, INTERMODAL | | | | | |
| Sub Category | Item | Quantity | Unit | Unit Cost | Total Cost |
| 20.01 | At-grade Station, Stop, Shelter, Platform | 5 | Each | \$ 3,023,565 | \$ 15,117,825 |
| 20 SUBTOTAL | | | | | \$ 15,117,825 |
| 20 ALLOCATED CONTINGENCY | | | | 30% | \$ 4,535,348 |
| 20 TOTAL | | | | | \$ 20,640,000 |
| 40 SITEWORK AND SPECIAL CONDITIONS | | | | | |
| Sub Category | Item | Quantity | Unit | Unit Cost | Total Cost |
| 40.01 | Demolition, Clearing, Earthwork | 2.50 | Route-Miles | \$ 500,000 | \$ 1,250,000 |
| 40.02 | Site Utilities, Utility Relocation | 2.50 | Route-miles | \$ 2,250,000 | \$ 5,625,000 |
| 40 SUBTOTAL | | | | | \$ 6,875,000 |
| 40 ALLOCATED CONTINGENCY | | | | 30% | \$ 2,062,500 |

Table 59 – Granary District, Ballpark Spur and 400 South Extensions Capital Cost Estimate

| 40 TOTAL | | | | | \$ 9,380,000 |
|--|---|----------|-------------|-----------------|----------------------|
| 50 SYSTEMS | | | | | |
| Sub Category | Item | Quantity | Unit | Unit Cost | Total Cost |
| 50.01 | Overhead Contact System (See Separate Estimate) | 1 | LS | \$ 6,392,000 | \$ 6,392,000 |
| 50.02 | Switch Machines and Signals | 1 | LS | \$ 2,500,000 | \$ 2,500,000 |
| 50.03 | Intersection LRT/Traffic Signal Controller Interfaces | 14 | Each | \$ 250,000 | \$ 3,500,000 |
| 50.04 | Traction Power Substations | 2.14 | Route-miles | \$ 1,850,000 | \$ 3,957,704 |
| 50 SUBTOTAL | | | | | \$ 16,349,704 |
| 50 ALLOCATED CONTINGENCY | | | | 30% | \$ 4,904,911 |
| 50 TOTAL | | | | | \$ 22,320,000 |
| 60 RIGHT OF WAY, LAND, EXISTING IMPROVEMENTS | | | | | |
| Sub Category | Item | Quantity | Unit | Unit Cost | Total Cost |
| 60.01 | Purchase of Part of Salvage Yard Paxton at Ave | 0.10 | Acre | \$ 1,524,600 | \$ 152,460 |
| 60.01 | Purchase of NE property NE corner of 900 S / 400 W | 0.05 | Acre | \$ 1,524,600 | \$ 76,230 |
| 60.01 | Purchase of property along 400 W between 800 S / 700 S | 0.32 | Acre | \$ 1,524,600 | \$ 487,872 |
| 60.02 | Partial demolition of building NE corner of 900 S / 400 W | 1 | LS | \$ 250,000 | \$ 250,000 |
| 60 SUBTOTAL | | | | | \$ 966,562 |
| 60 ALLOCATED CONTINGENCY | | | | 30% | \$ 289,969 |
| 60 TOTAL | | | | | \$ 1,320,000 |
| 70 VEHICLES | | | | | |
| Sub Category | Item | Quantity | Unit | Unit Cost | Total Cost |
| | | | | \$ - | \$ - |
| | | | | \$ - | \$ - |
| 70 SUBTOTAL | | | | | \$ - |
| 70 ALLOCATED CONTINGENCY | | | | 0% | \$ - |
| 70 TOTAL | | | | | \$ - |
| 80 PROFESSIONAL SERVICES | | | | | |
| SCC 10 - 50 TOTAL | | | | | \$ 52,340,000 |
| Sub Category | Total Cost | | | %of SCC 10 - 50 | Total Cost |
| 80.01 | Preliminary Engineering | | | 3% | \$ 1,570,200 |
| 80.02 | Final Design | | | 7% | \$ 3,663,800 |
| 80.03 | Project Management for Design and Construction | | | 5% | \$ 2,617,000 |
| 80.04 | Construction Administration and Management | | | 6% | \$ 3,140,400 |
| 80.05 | Insurance | | | 3% | \$ 1,570,200 |
| 80.06 | Legal, Permits, Review Fees | | | 2% | \$ 1,046,800 |
| 80.07 | Survey, Testing, Investigation, Inspection | | | 2% | \$ 1,046,800 |
| 80.08 | Start-up Costs | | | 2% | \$ 1,046,800 |
| 80 TOTAL | | | | | \$ 16,490,000 |
| Summary | | | | | |
| Standard Cost Category | | | | | Total Cost |
| SCC 10: Guideway and Track Elements | | | | | \$ 25,190,000 |
| SCC 20: Stations, Stops, Terminals, Intermodal | | | | | \$ 20,640,000 |
| SCC 30: Support Facilities, Yards, Shops, Administration Buildings | | | | | \$ - |
| SCC 40: Sitework and Special Conditions | | | | | \$ 9,380,000 |
| SCC 50: Systems | | | | | \$ 22,320,000 |

Table 59 – Granary District, Ballpark Spur and 400 South Extensions Capital Cost Estimate

| | | | |
|---|-----|----|--------------------|
| SCC 60: Right of Way, Land, Existing Improvements | | \$ | 1,320,000 |
| SCC 70: Vehicles | | \$ | - |
| SCC 80: Professional Services | | \$ | 16,490,000 |
| SUBTOTAL | | \$ | 95,340,000 |
| UNALLOCATED CONTINGENCY | 30% | \$ | 28,602,000 |
| PROJECT TOTAL | | \$ | 123,940,000 |

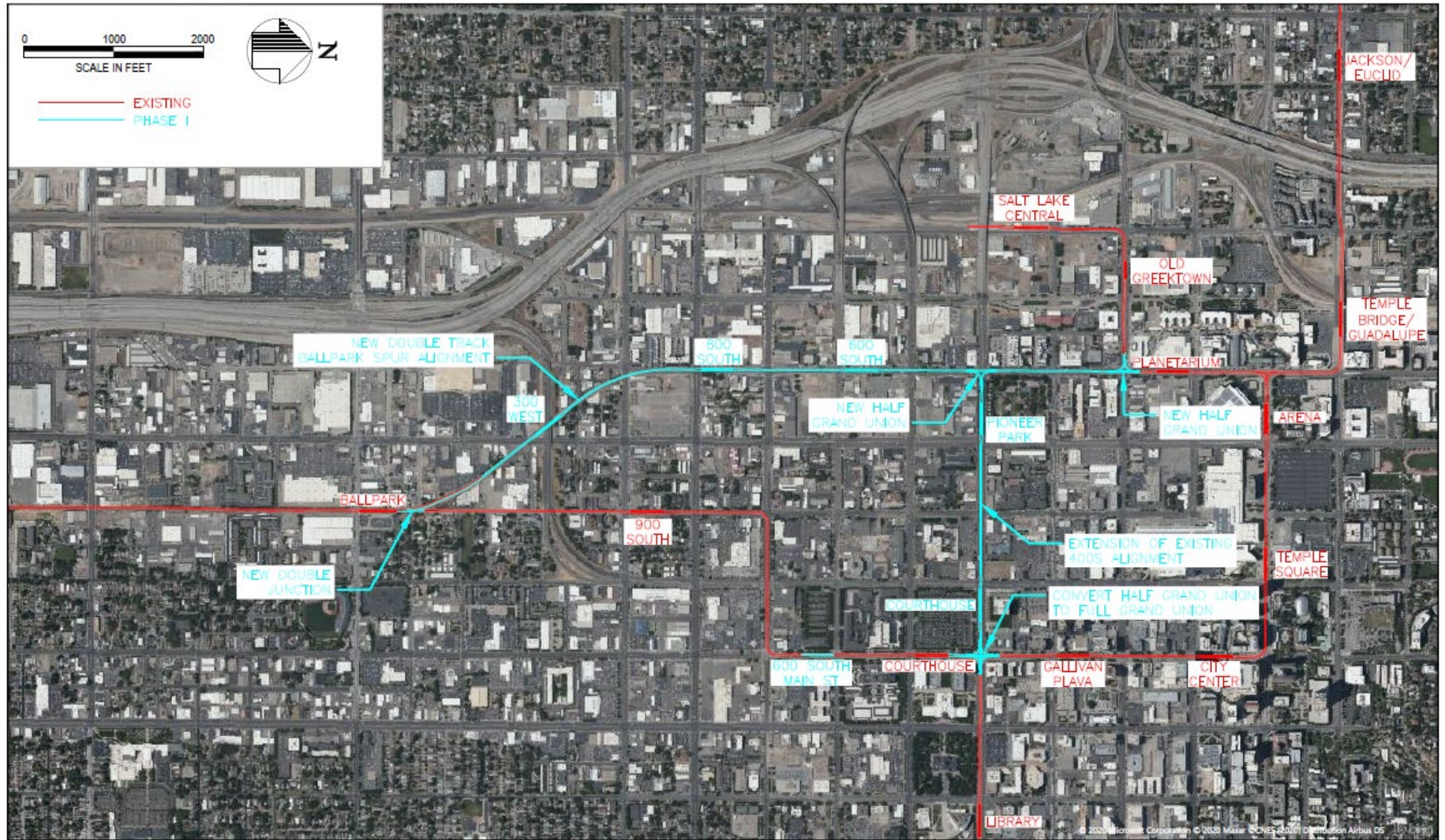

Figure 27 – Granary District Ballpark Spur and 400 South Extensions Concept Design Overview

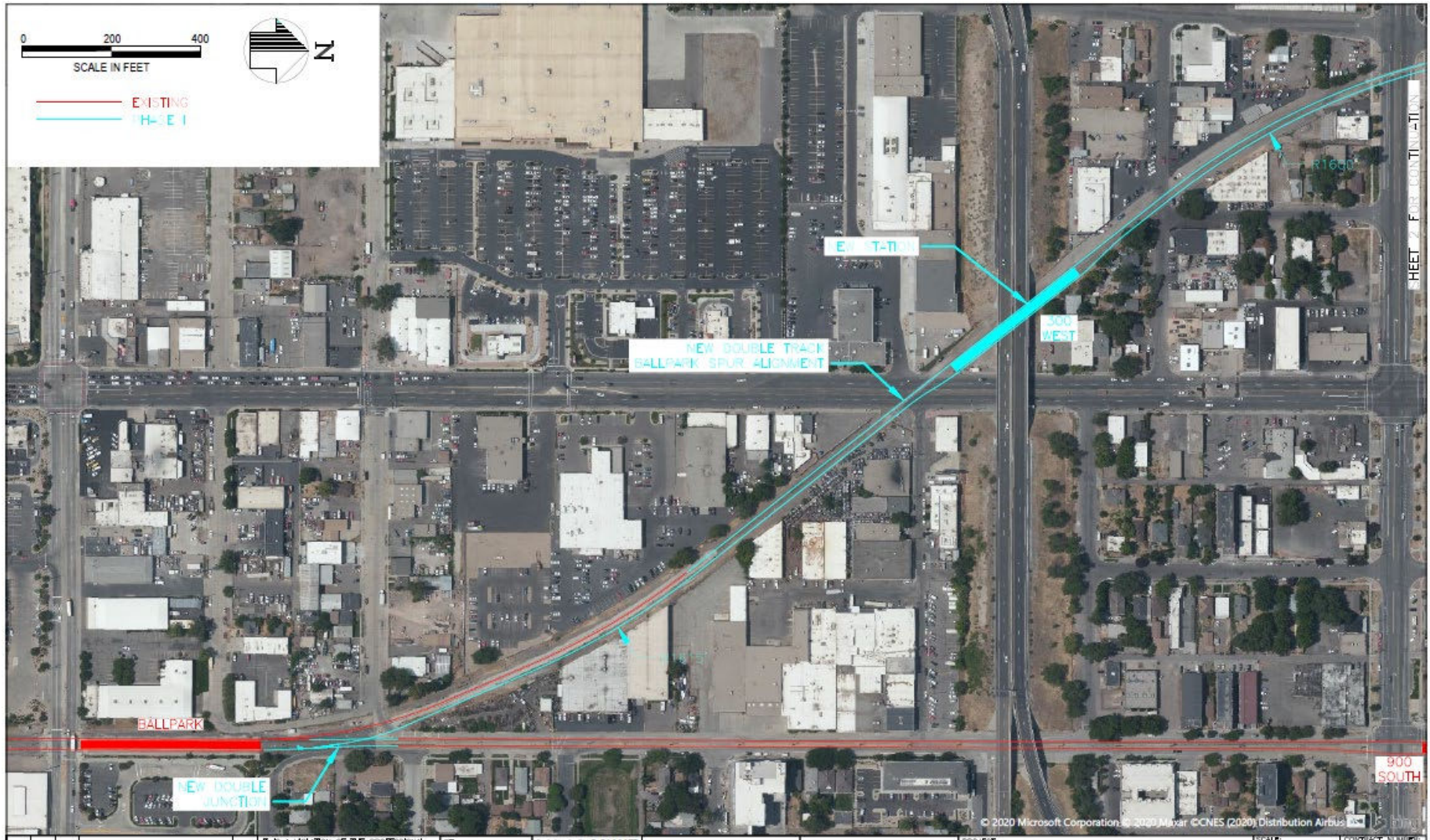

Figure 28 – Granary District Ballpark Spur Extension and Ballpark Station Concept Design



Figure 29 – Granary District Ballpark Spur Extension Concept Design at 700 South

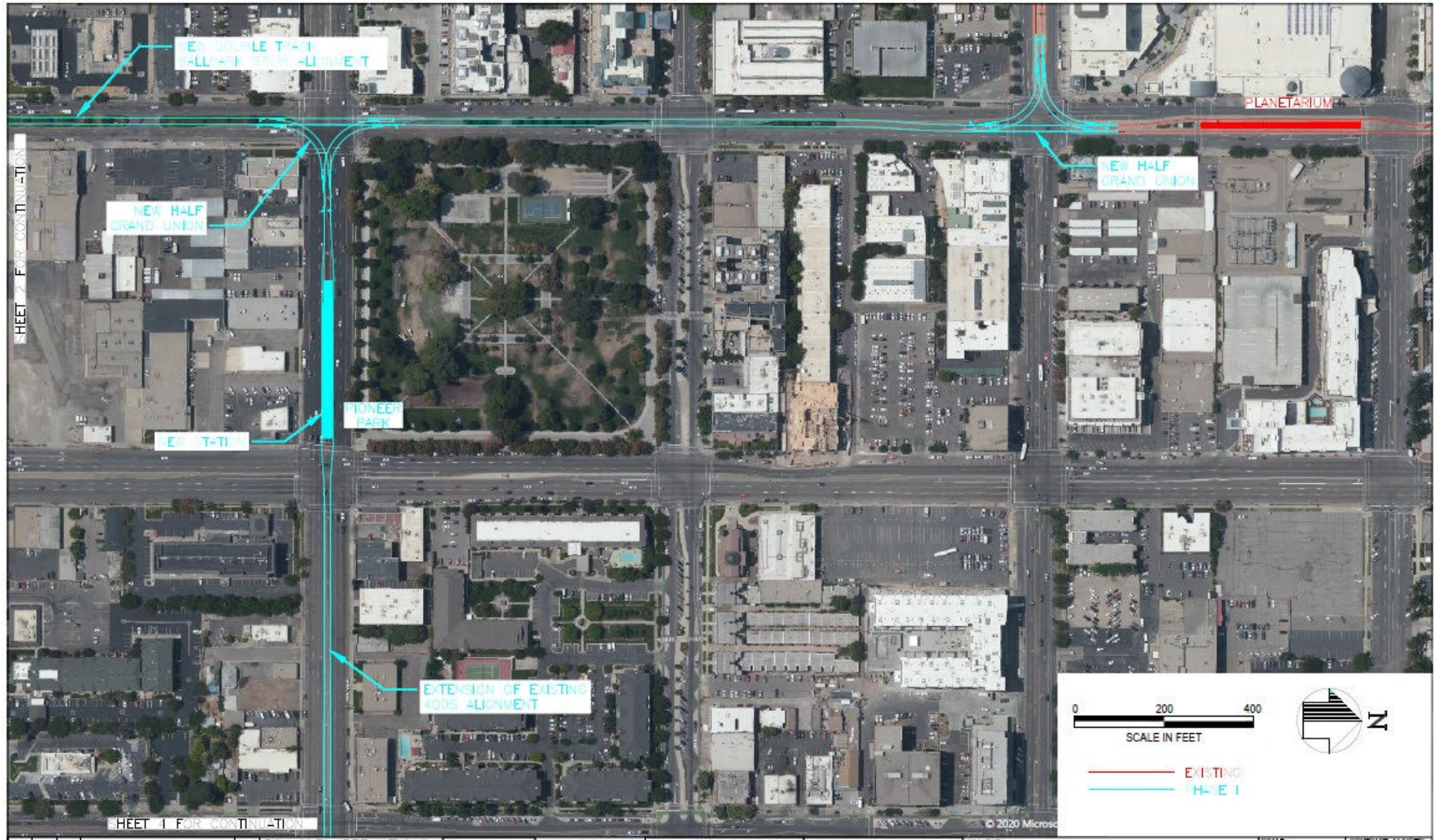

Figure 30 – Granary District Ballpark Spur Extension on 400 West and 400 South at Pioneer Park

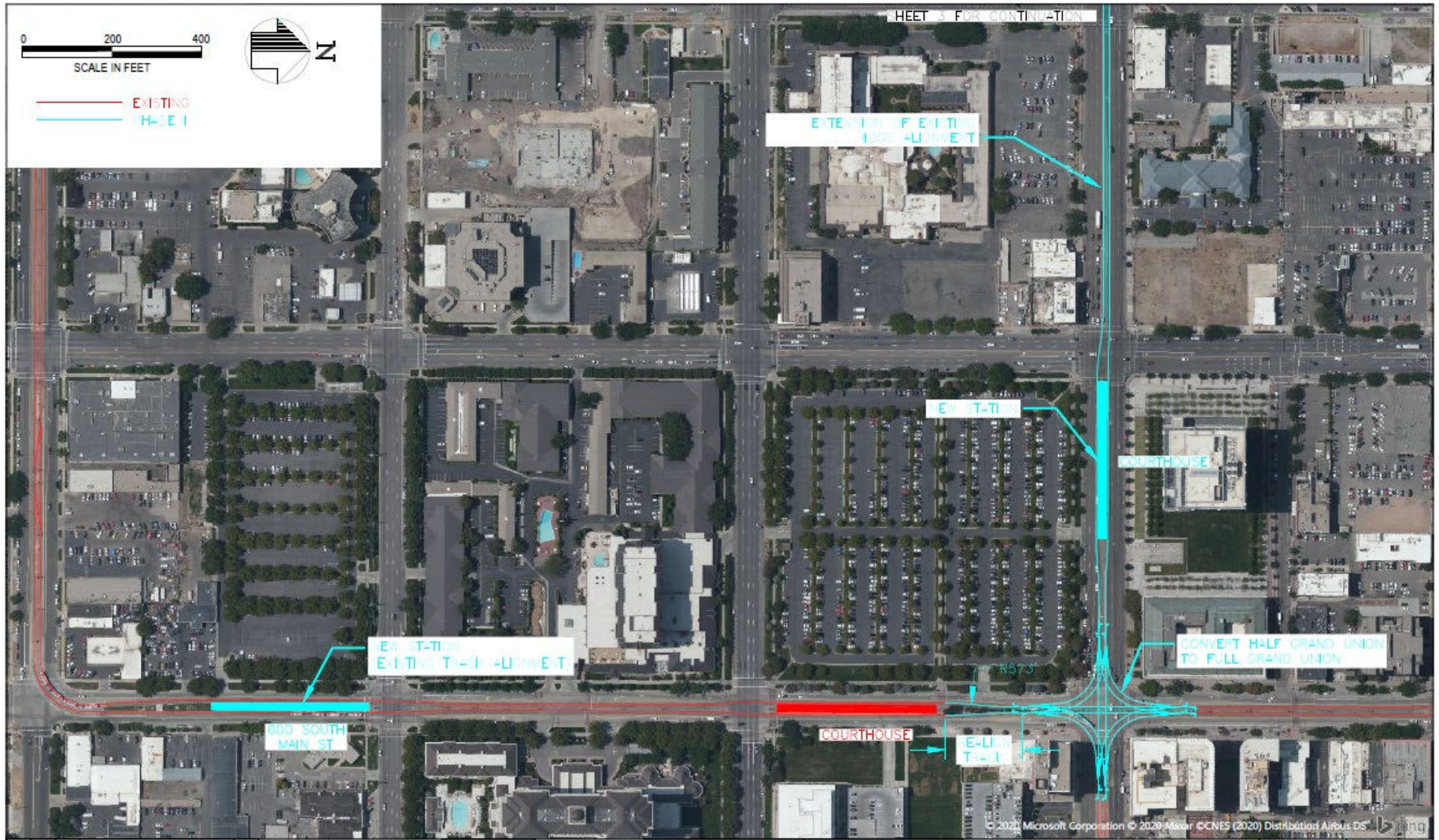

Figure 31 – 400 South Extension Concept Design at Courthouse Grand Union

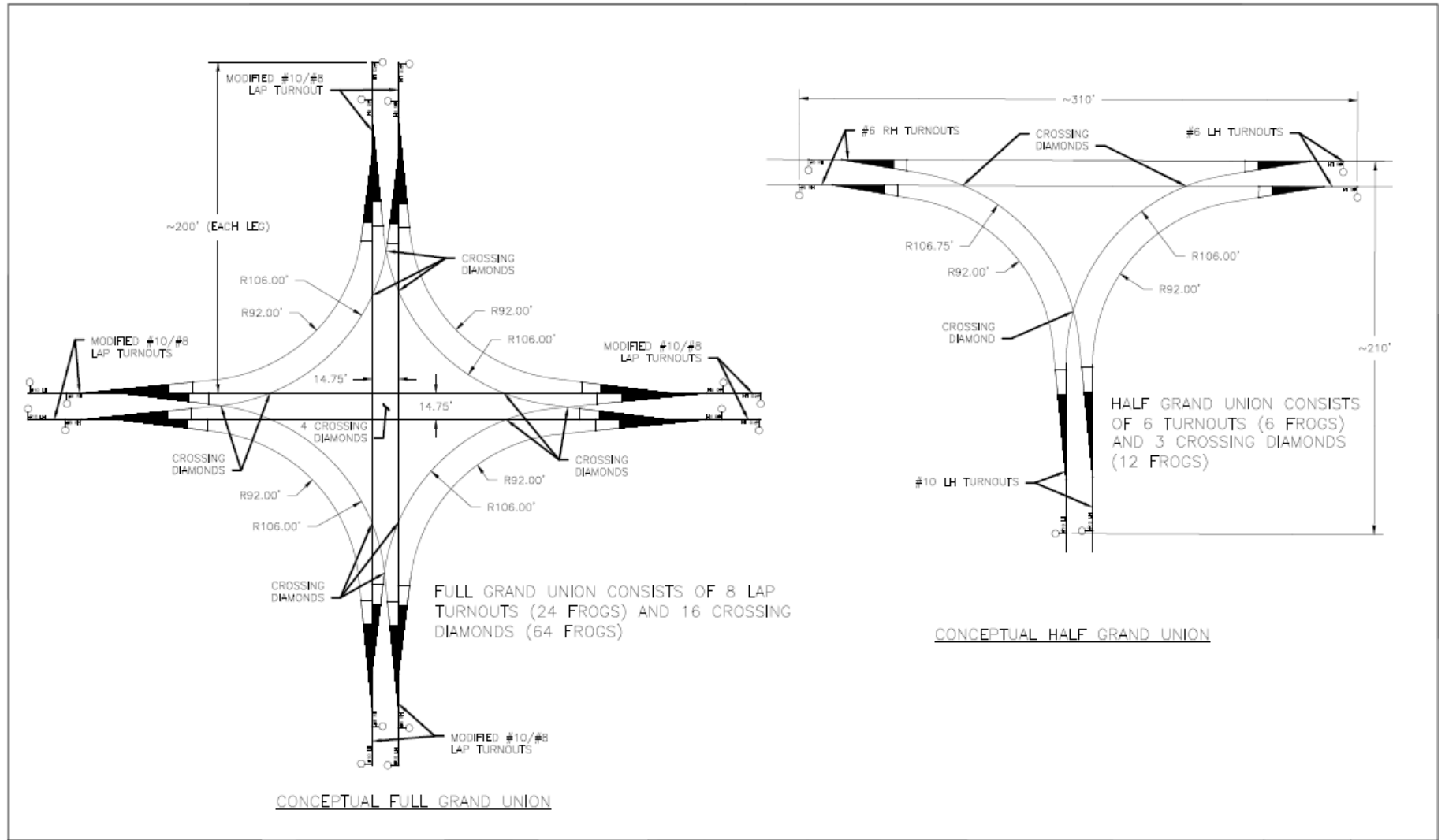

Figure 32 – Granary District Ballpark Spur and 400 South Extensions Concept Design – Grand Union and Half Grand Union Layouts

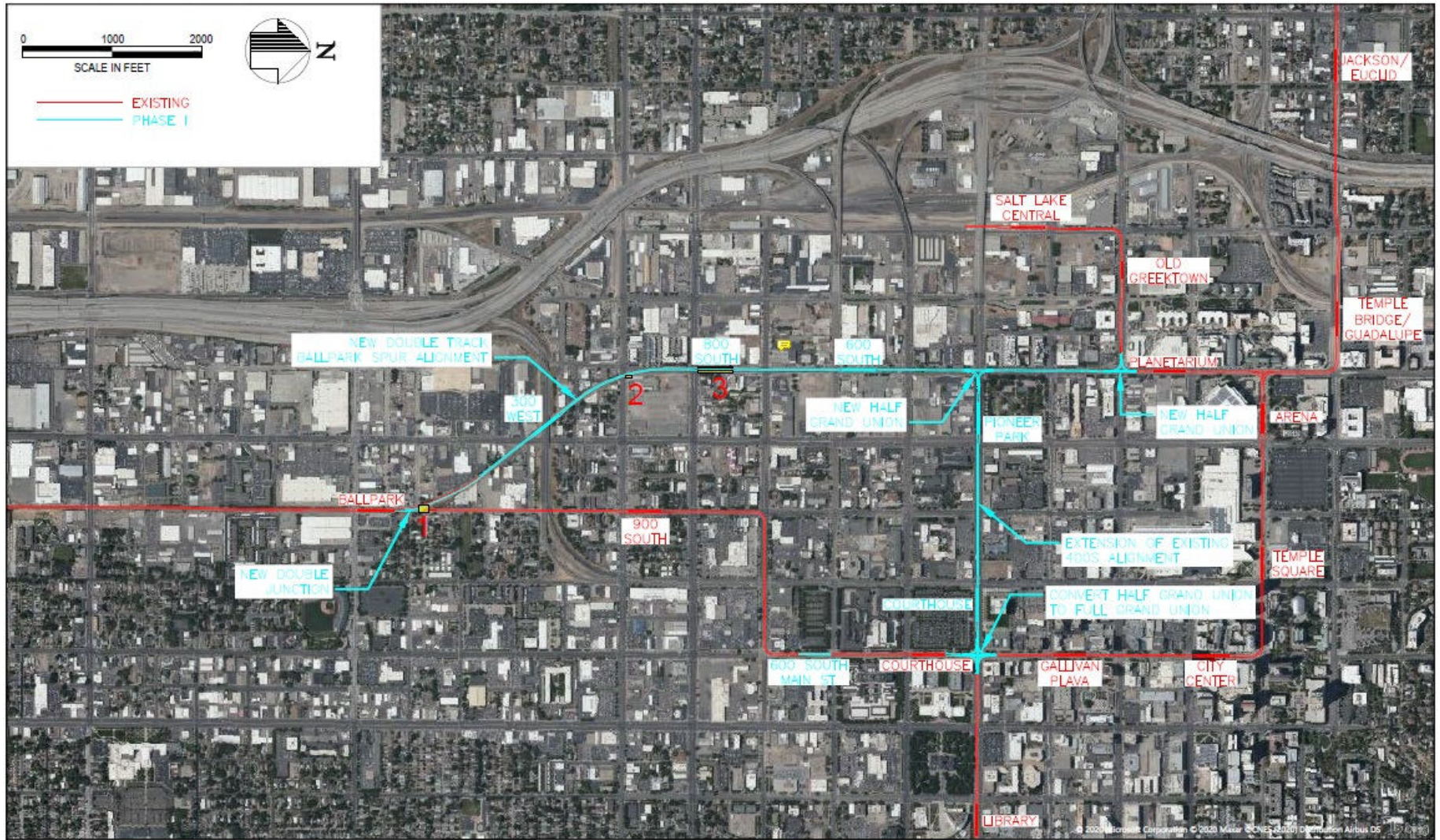

Figure 33 – Granary District Ballpark Spur and 400 South Extensions Concept Design Overview with Potential Property Acquisition Locations

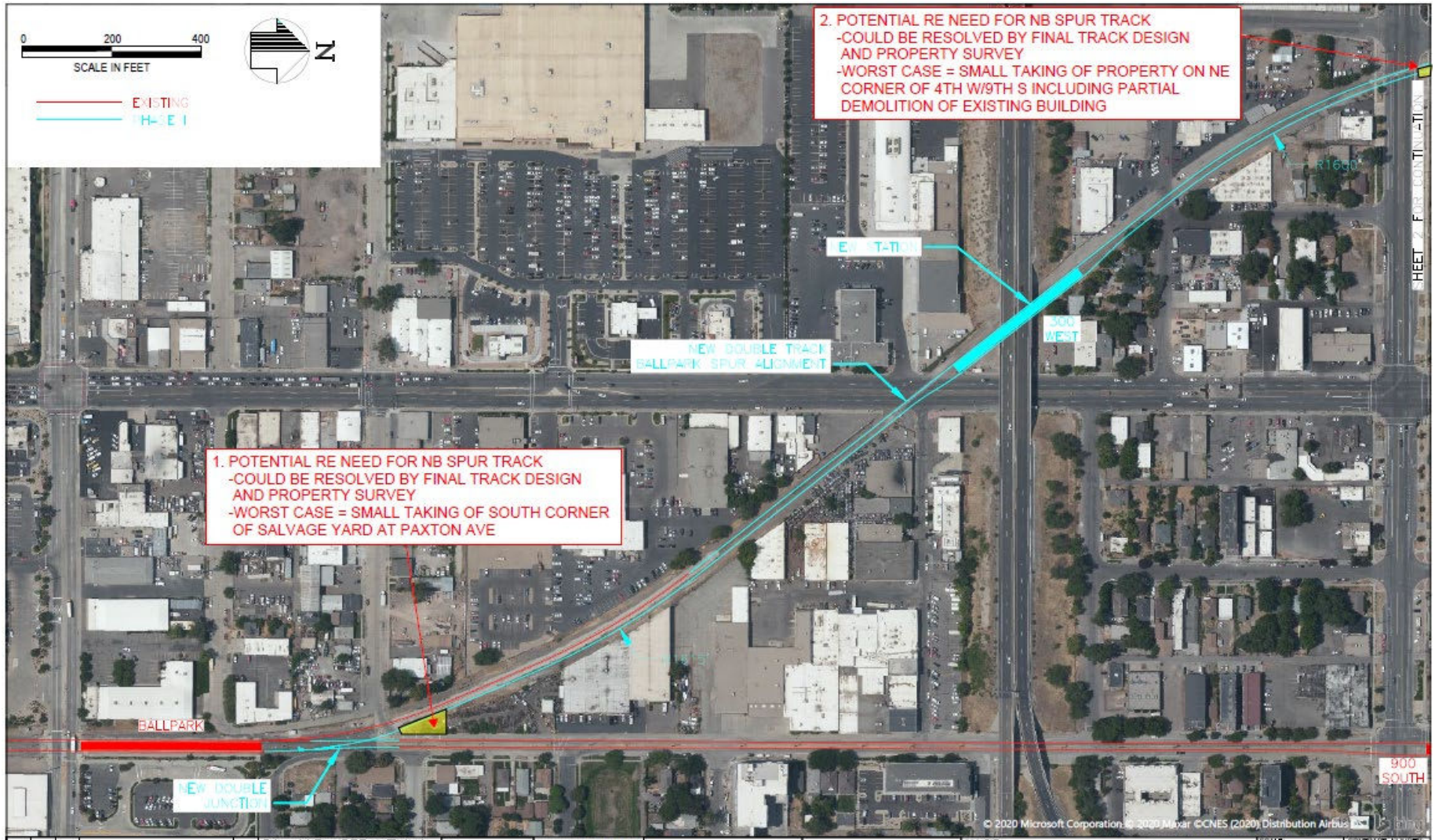

Figure 34 – Granary District Ballpark Spur and 400 South Extensions Concept Design – Potential Ballpark Property Acquisition

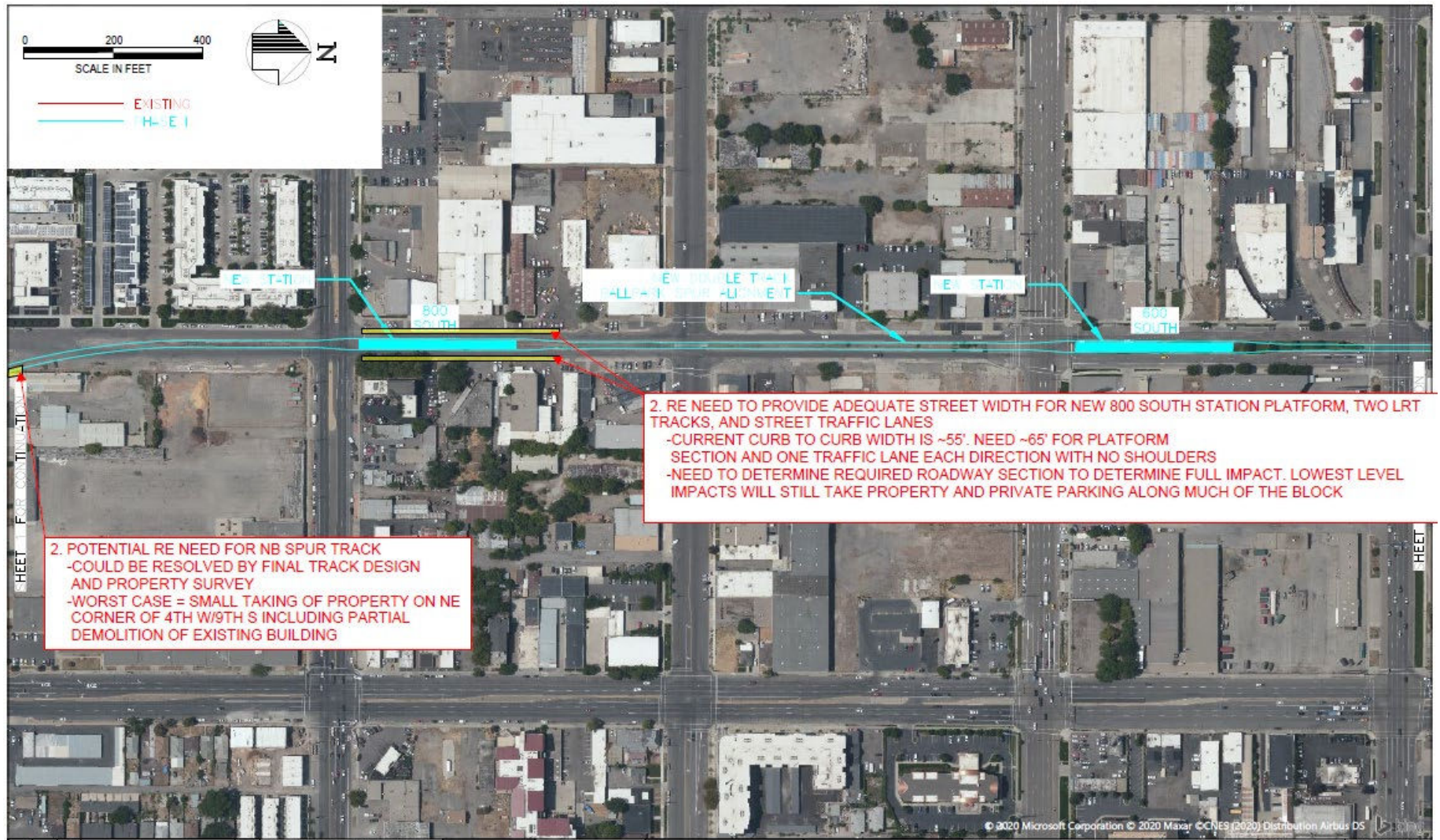

Figure 35 – Granary District Ballpark Spur and 400 South Extensions Concept Design – Potential 900 South and 800 South Property Acquisitions

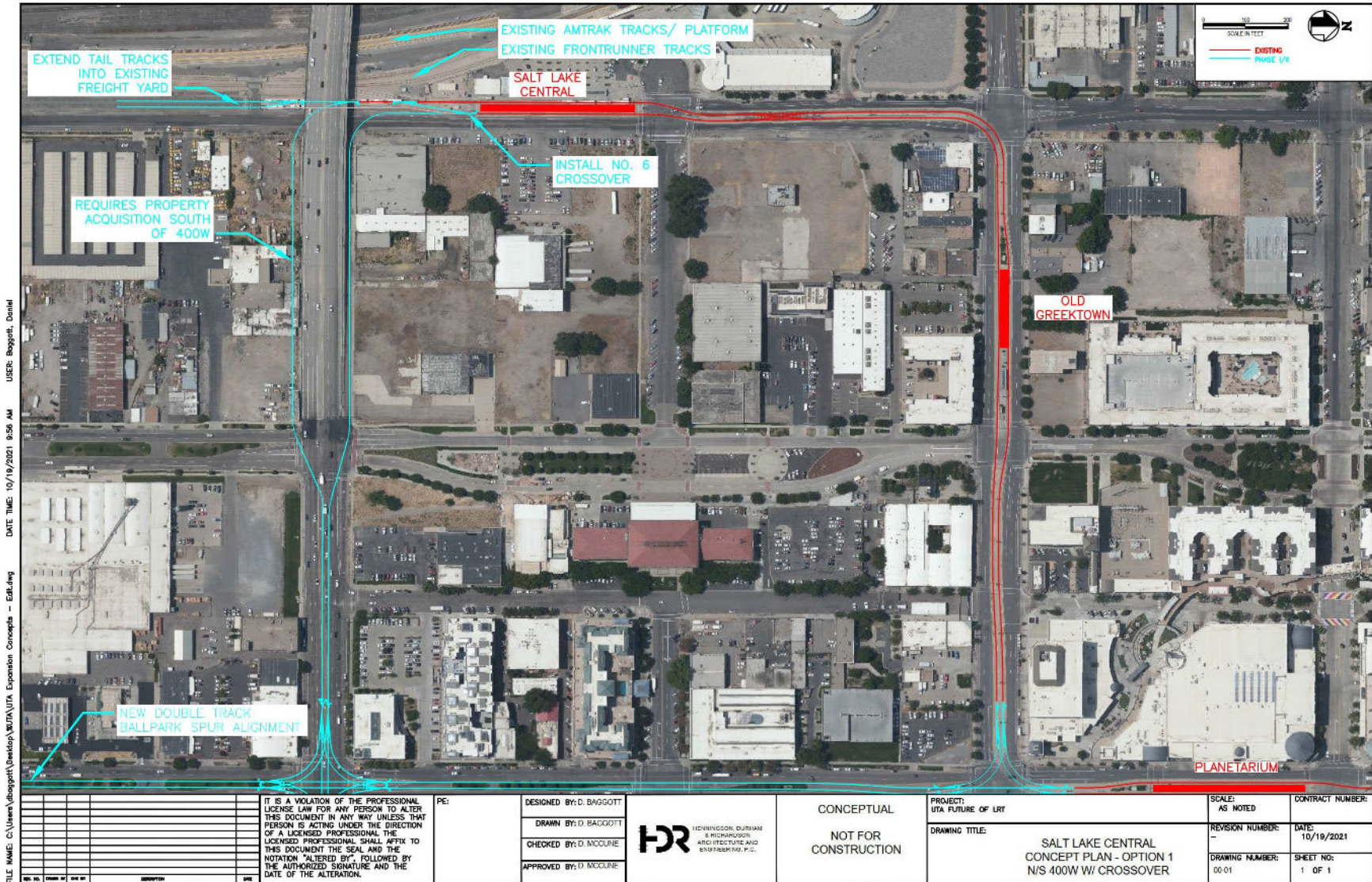

Figure 36 – Revised Connection from Ballpark Spur to Salt Lake Central via 400 South/600 West

15 Appendix F – 400 West (Pioneer Park) Non-Revenue Connector Concept Design

Phase 2 of the FOLR Study evaluated how best to serve the Granary District and Salt Lake Central. The Phase 1 Ballpark Spur/400 South concept which served Salt Lake Central from the north (by joining the existing Blue Line at 400 West/200 South) was revised to serve Salt Lake Central from the south. This includes additional westward TRAX extension on 400 South, turning northward on 600 West. This eliminated the short segment on the west side of Pioneer Park from 400 South to 200 South.

Subsequently, the UTA Light Rail Business Unit requested that this two-block segment be restored to the Plan with the understanding that it would be used as a non-revenue connector. It would provide system resiliency in the event of a blockage at Salt Lake Central or on Main Street by allowing trains to be routed around closed or blocked tracks (thus reducing the possible need for a bus bridge) and would provide the ability to stage non-revenue trains awaiting the end of a special event at the arena or Temple Square. Finally, the Light Rail Business Unit felt that the connector could serve as a location to “pocket” a disabled train, with access from the Ballpark Spur, 400 South and Main Street (currently the Ballpark Spur is used as a location to “pocket” a disabled train, but with that track becoming mainline track as recommended in this Strategic Plan, an alternate emergency storage location is needed). The track layout, prior to the Strategic Plan’s westward extension of the new track on 400 South, is shown in Figure 37.

On this basis, the project was included in the Strategic Plan. Because the non-revenue connector does not support regularly-scheduled service, its benefits were not captured through rail network simulation.

The detailed capital cost estimate using FRA Standard Cost Categories for the 400 West Non-Revenue Connector is shown in Table 60. The 0.37-mile connector has been assigned its pro rata share of traction power substation costs, consistent with other FOLR capital cost estimates. The need for and siting of a new traction power substation would require a traction power load flow study to determine. The major cost components in the \$16.4 million estimated cost are trackwork, signals and Overhead Contact System (OCS), as well as the pro rata share of new substation costs. Signals cost assumes that the connector is built at the same time as other Granary District TRAX improvements with half grand union at 400 South/400 West upgraded to a full grand union and a new half grand union constructed at 200 South/400 West.

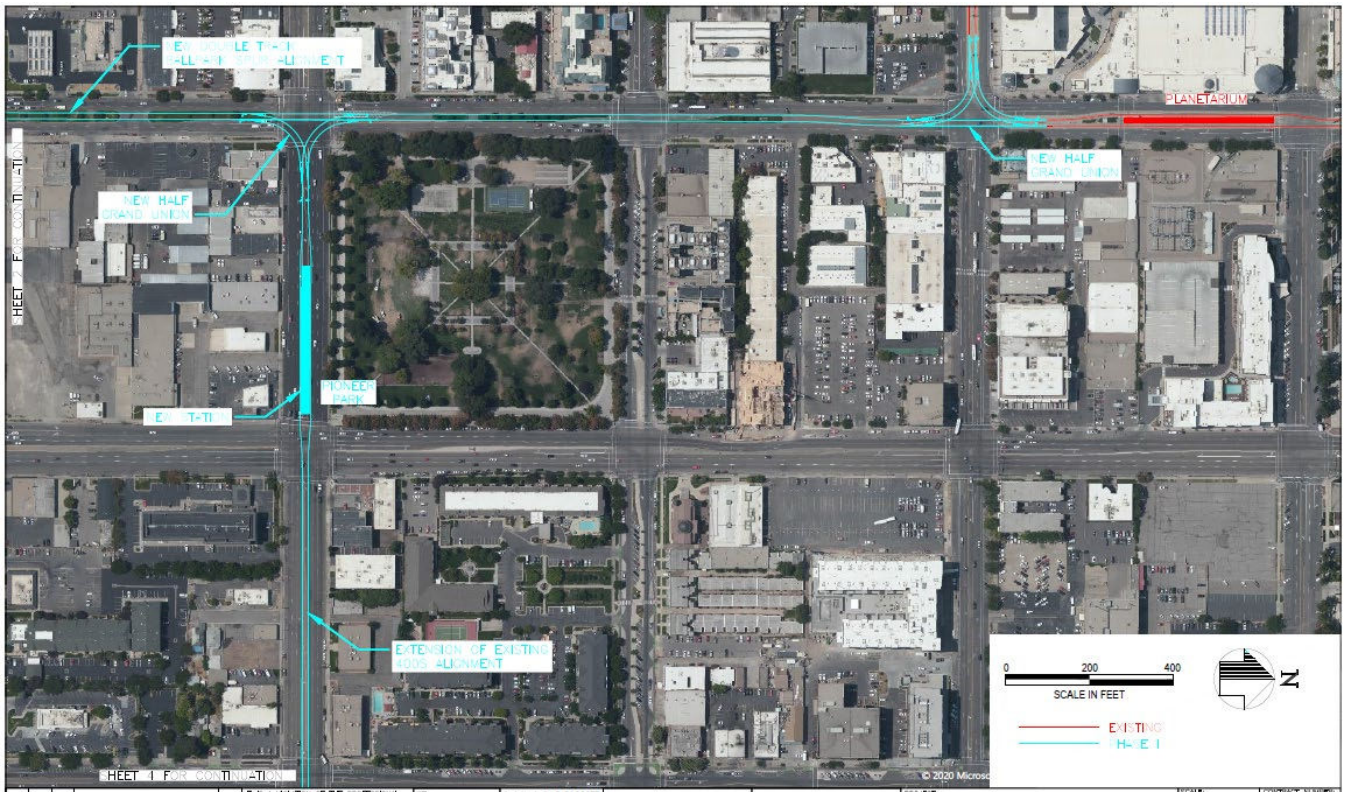

Figure 37 – 400 West (Pioneer Park) Non-Revenue Connector Between 400 South and Existing Blue Line on 200 South (prior to further westward extension of the proposed line on 400 South)

| Table 60 – 400 West (Pioneer Park) Non-Revenue Connector Capital Cost Estimate | | | | | |
|--|--|----------|-------------|--------------|---------------------|
| 10 GUIDEWAY AND TRACK ELEMENTS | | | | | |
| Sub Category | Item | Quantity | Unit | Unit Cost | Total Cost |
| 10.01 | Guideway: At-grade Exclusive ROW | 0 | Route-miles | \$ 680,000 | \$ - |
| 10.03 | Guideway: At-grade in Mixed Traffic | 0.37 | Route-miles | \$ 1,750,000 | \$ 647,500 |
| 10.10 | Track: Embedded | 0.37 | Route-miles | \$ 5,750,000 | \$ 2,127,500 |
| 10.11 | Track: Ballasted | 0 | Route-miles | \$ 2,650,000 | \$ - |
| 10.12 | Track: Special - New Half Grand Union | 1 | Each | \$ 350,000 | \$ 350,000 |
| 10.12 | Track: Special - Convert Existing Half to Full Grand Union | 1 | Each | \$ 450,000 | \$ 450,000 |
| 10.12 | Track: Special - No. 8 Turnout | 4 | Each | \$ 150,000 | \$ 600,000 |
| 10.12 | Track: Special - Double Junction | 0 | Each | \$ 250,000 | \$ - |
| 10.01 | Guideway: At-grade Exclusive ROW | 0 | Route-miles | \$ 680,000 | \$ - |
| 10 SUBTOTAL | | | | | \$ 4,175,000 |
| 10 ALLOCATED CONTINGENCY | | | | 30% | \$ 1,252,500 |
| 10 TOTAL | | | | | \$ 5,700,000 |
| 20 STATIONS, SHOPS, TERMINALS, INTERMODAL | | | | | |
| Sub Category | Item | Quantity | Unit | Unit Cost | Total Cost |
| | | | | \$ - | \$ - |
| 20 SUBTOTAL | | | | | \$ - |
| 20 ALLOCATED CONTINGENCY | | | | 30% | \$ - |
| 20 TOTAL | | | | | \$ - |
| 40 SITEWORK AND SPECIAL CONDITIONS | | | | | |
| Sub Category | Item | Quantity | Unit | Unit Cost | Total Cost |
| 40.01 | Demolition, Clearing, Earthwork | 0.37 | Route-Miles | \$ 500,000 | \$ 185,000 |
| 40.02 | Site Utilities, Utility Relocation | 0.37 | Route-miles | \$ 2,250,000 | \$ 832,500 |

Table 60 – 400 West (Pioneer Park) Non-Revenue Connector Capital Cost Estimate

| 40 SUBTOTAL | | | | | \$ | 1,017,500 |
|--|---|----------|-------------|------------------|--------------|-------------------|
| 40 ALLOCATED CONTINGENCY | | | | | 30% | \$ 305,250 |
| 40 TOTAL | | | | | \$ | 1,390,000 |
| 50 SYSTEMS | | | | | | |
| Sub Category | Item | Quantity | Unit | Unit Cost | Total Cost | |
| 50.01 | Overhead Contact System | 1 | LS | \$ 946,016 | \$ 946,016 | |
| 50.02 | Switch Machines and Signals | 1 | LS | \$ 930,000 | \$ 930,000 | |
| 50.03 | Intersection LRT/Traffic Signal Controller Interfaces | 1 | Each | \$ 250,000 | \$ 250,000 | |
| 50.04 | Traction Power Substations | 0.37 | Route-miles | \$ 1,850,000 | \$ 684,500 | |
| | | | | | \$ - | \$ - |
| 50 SUBTOTAL | | | | | | \$ 2,810,516 |
| 50 ALLOCATED CONTINGENCY | | | | | 30% | \$ 843,155 |
| 50 TOTAL | | | | | \$ | 3,840,000 |
| 60 RIGHT OF WAY, LAND, EXISTING IMPROVEMENTS | | | | | | |
| Sub Category | Item | Quantity | Unit | Unit Cost | Total Cost | |
| 60.01 | | | Acre | \$ | \$ | |
| 60 SUBTOTAL | | | | | | \$ |
| 60 ALLOCATED CONTINGENCY | | | | | 30% | \$ |
| 60 TOTAL | | | | | \$ | \$ |
| 70 VEHICLES | | | | | | |
| Sub Category | Item | Quantity | Unit | Unit Cost | Total Cost | |
| | | | | | \$ - | \$ - |
| | | | | | \$ - | \$ - |
| 70 SUBTOTAL | | | | | | \$ - |
| 70 ALLOCATED CONTINGENCY | | | | | 0% | \$ - |
| 70 TOTAL | | | | | \$ | \$ - |
| 80 PROFESSIONAL SERVICES | | | | | | |
| SCC 10 - 50 TOTAL | | | | | \$ | 5,230,000 |
| Sub Category | Item | | | % of SCC 10 - 50 | Total Cost | |
| 80.01 | Preliminary Engineering | | | 3% | \$ 156,900 | |
| 80.02 | Final Design | | | 7% | \$ 366,100 | |
| 80.03 | Project Management for Design and Construction | | | 5% | \$ 261,500 | |
| 80.04 | Construction Administration and Management | | | 6% | \$ 313,800 | |
| 80.05 | Insurance | | | 3% | \$ 156,900 | |
| 80.06 | Legal, Permits, Review Fees | | | 2% | \$ 104,600 | |
| 80.07 | Survey, Testing, Investigation, Inspection | | | 2% | \$ 104,600 | |
| 80.08 | Start-up Costs | | | 2% | \$ 104,600 | |
| 80 TOTAL | | | | | \$ | 1,650,000 |
| Summary | | | | | | |
| Standard Cost Category | | | | | Total Cost | |
| SCC 10: Guideway and Track Elements | | | | | \$ 5,700,000 | |
| SCC 20: Stations, Stops, Terminals, Intermodal | | | | | \$ - | |
| SCC 30: Support Facilities, Yards, Shops, Administration Buildings | | | | | \$ - | |
| SCC 40: Sitework and Special Conditions | | | | | \$ 1,390,000 | |
| SCC 50: Systems | | | | | \$ 3,840,000 | |
| SCC 60: Right of Way, Land, Existing Improvements | | | | | \$ - | |
| SCC 70: Vehicles | | | | | \$ - | |
| SCC 80: Professional Services | | | | | \$ 1,650,000 | |
| SUBTOTAL | | | | | \$ | 12,580,000 |
| UNALLOCATED CONTINGENCY | | | | | 30% | \$ 3,774,000 |
| PROJECT TOTAL | | | | | \$ | 16,350,000 |

16 Appendix G – Research Park Branch Concept Design

The Strategic Plan’s Research Park Branch concept design is based on the October, 2020 University of Utah’s Research Park Strategic Vision Plan and its specific recommendations related to High Capacity Transit (HCT). The University’s Vision Plan evaluated existing conditions and recommended transportation network improvements corresponding to two future planning horizons:

- + Phase 2 (10-Year) Conditions (2030) – Future traffic conditions based on the WFRC regional travel demand model projected growth for 2030 and Research Park transit mode share associated with the Phase 2 HCT network vision
- + Phase 3 (20-Year) Conditions (2040) – Future traffic conditions based on the WFRC regional travel demand model projected growth for 2040 and Research Park transit mode share associated with the Phase 3 HCT network vision

The most significant HCT recommendations of the Strategic Vision Plan are construction of the Arapeen Connector, a transit, bicycle, and pedestrian only roadway linking South Campus Drive to Arapeen Drive for expedited HCT vehicle circulation, access and egress to Research Park, and implementing the Campus Circuit, a program of transit priority treatments connecting to the Arapeen Connector.

Figure 38 shows the Arapeen Connector and the overall planned transit alignment from a connection with the University (Red) Line on South Campus Dr. near Soldier’s Circle. The approximately 2900-foot alignment, assumed to be full double track, continues southeast to Arapeen Drive and Wakara Way, just west of Blackhawk Way. According to the University’s Vision Plan, the connector would start at the existing intersection of South Campus Drive and Mario Capecchi Drive and proceed to the southern bank of Red Butte Creek, where a new multimodal bridge crossing will be constructed. The Vision Plan notes “although TRAX LRT extension to Research Park is not proposed until the Phase 3 horizon, the Arapeen Connector would preserve right of way for a continuous single track of rail guideway between South Campus Drive and the new proposed terminal station at Wakara Way and Arapeen Drive.” The Vision Plan notes that a special, transit-only signal phase would be required at the intersection of Mario Capecchi Drive, South Campus Drive, and the Arapeen Connector to facilitate the transit vehicle access/egress of the facility’s northern end. It also notes that transit-only access would be controlled with signage and pavement markings at the southern bank of the Red Butte Creek bridge where the Connector would join the existing Arapeen Drive.

For the purpose of the Light Rail Strategic Plan, the Research Park Branch was assumed to be full double track with a traditional two-track UTA terminal on Arapeen Drive. This differs from the University’s concept cross-section, shown in Figure 39, which suggests a single track light rail alignment side-by-side with two bus lanes for BRT operation. UTA Light Rail Operations noted that the full extension to Research Park would need to be double track to avoid capacity bottlenecks. This is especially true during frequent special events service operation for University of Utah athletic events, concerts, commencement and similar large travel demand periods; these require dispatching of multiple trains on close headways that a single track alignment cannot support.

Although the University’s Strategic Vision contains no details on a TRAX station concept, the Light Rail Strategic Plan assumes that there would be a 340-foot center island platform with a universal interlocking on the west side with four-car tail track extending to the east. This configuration would accommodate four four-car trains at the station, an important capability for special events operations serving Rice-Eccles Stadium and the Huntsman Center such as football games, gymnastics meets, basketball games, and concerts.

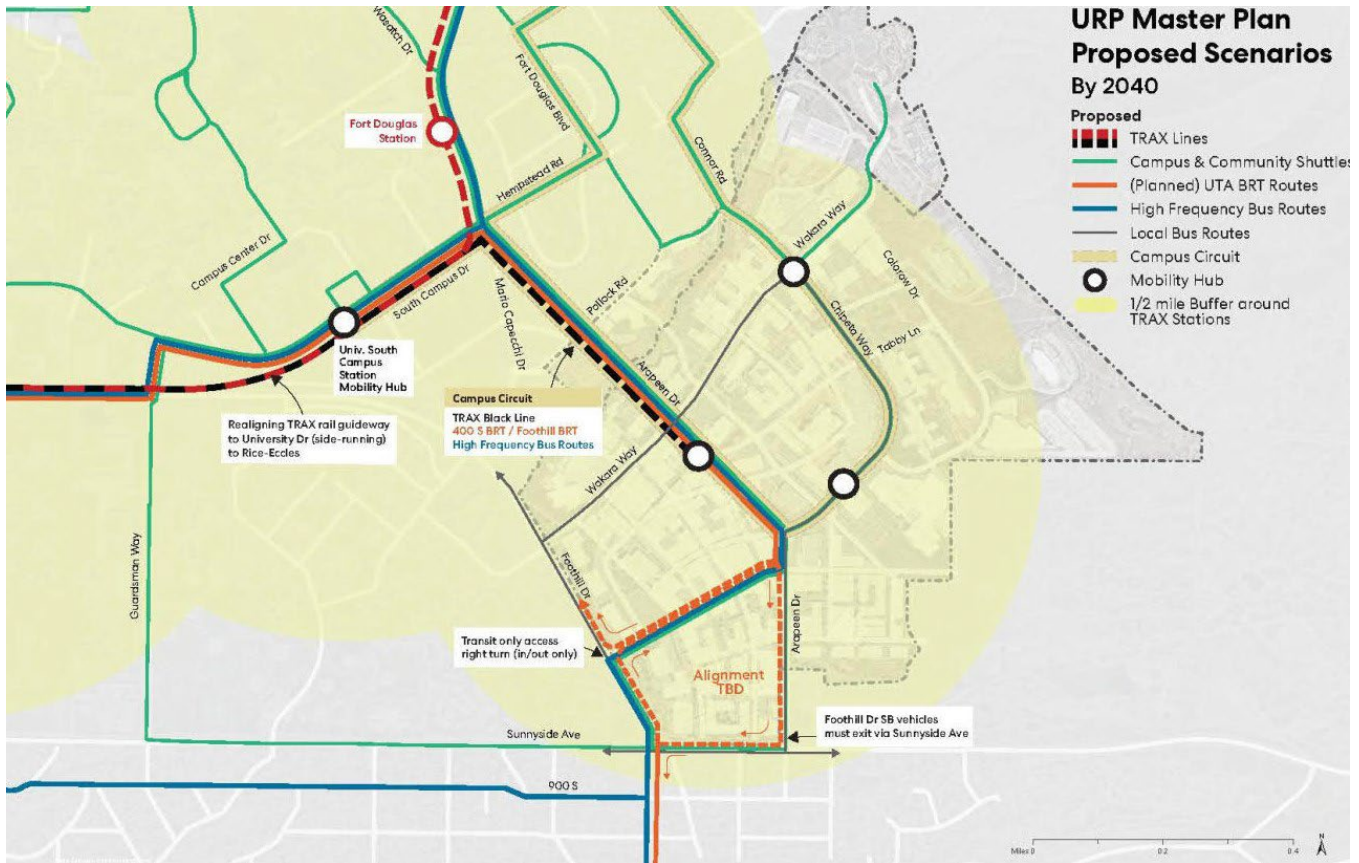

Figure 38 – University of Utah proposed Research Park Branch Concept Alignment (Dashed Black Line)

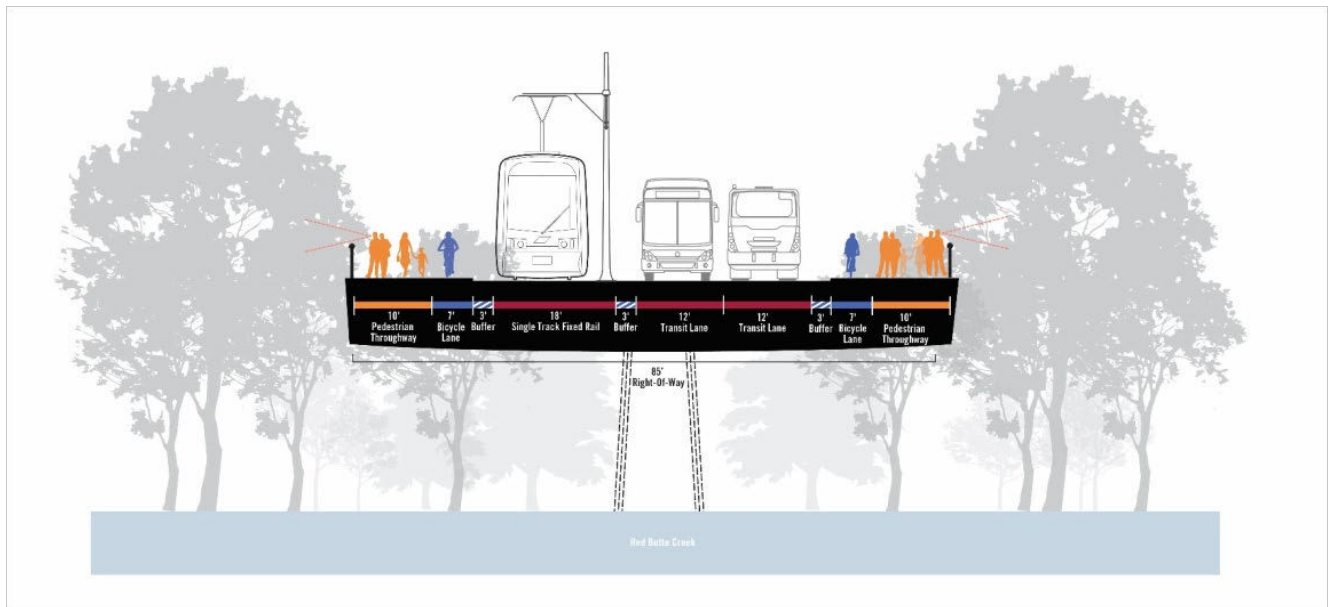

Figure 39 – University of Utah Vision Plan showing cross-section of proposed Arapleen Connector (note that this represents the proposed cross-section in the context of forested land and is not meant to indicate that an elevated structure is proposed)

The \$30.4 million total estimated cost (in 2022 dollars) of the TRAX extension to a new Research Park Station is shown in Table 61. The cost is spread among rail systems (dominated by the new terminal interlocking), guideway, station and

sitework construction costs. Although the extension will require some dedicated guideway outside of the street grid, it is assumed that the University of Utah is acquiring/providing the extension’s right of way as part of the larger Arapeen Connector project. The total estimated cost of the project includes 30% allocated contingency for each of the standard FTA cost categories as well as 30% unallocated contingency. The estimate also includes professional services and other “soft” costs using standard cost factors.

| Table 61 – Research Park Branch Capital Cost Estimate | | | | | |
|--|--|-----------------|-------------|------------------|---------------------|
| 10 GUIDEWAY AND TRACK ELEMENTS | | | | | |
| Sub Category | Item | Quantity | Unit | Unit Cost | Total Cost |
| 10.01 | Guideway: At-grade Exclusive ROW | 0.34 | Route-miles | \$ 680,000 | \$ 231,818 |
| 10.03 | Guideway: At-grade in Mixed Traffic | 0.21 | Route-miles | \$ 1,750,000 | \$ 364,583 |
| 10.10 | Track: Embedded | 0.21 | Route-miles | \$ 5,750,000 | \$ 1,197,917 |
| 10.11 | Track: Ballasted | 0.34 | Route-miles | \$ 2,650,000 | \$ 903,409 |
| 10.12 | Track: Special - New Half Grand Union | 1 | Each | \$ 350,000 | \$ 350,000 |
| 10.12 | Track: Special - Convert Existing Half to Full Grand Union | 0 | Each | \$ 450,000 | \$ - |
| 10.12 | Track: Special - No. 8 Turnout | 2 | Each | \$ 150,000 | \$ 300,000 |
| 10.12 | Track: Special - Double Junction | 0 | Each | \$ 250,000 | \$ - |
| 10 SUBTOTAL | | | | | \$ 3,347,727 |
| 10 ALLOCATED CONTINGENCY | | | | 30% | \$ 1,004,318 |
| 10 TOTAL | | | | | \$ 4,570,000 |
| 20 STATIONS, SHOPS, TERMINALS, INTERMODAL | | | | | |
| Sub Category | Item | Quantity | Unit | Unit Cost | Total Cost |
| 20.01 | At-grade Station, Stop, Shelter, Platform | 1 | Each | \$ 3,023,565 | \$ 3,023,565 |
| 20 SUBTOTAL | | | | | \$ 3,023,565 |
| 20 ALLOCATED CONTINGENCY | | | | 30% | \$ 907,070 |
| 20 TOTAL | | | | | \$ 4,130,000 |
| 40 SITEWORK AND SPECIAL CONDITIONS | | | | | |
| Sub Category | Item | Quantity | Unit | Unit Cost | Total Cost |
| 40.01 | Demolition, Clearing, Earthwork | 0.55 | Route-Miles | \$ 500,000 | \$ 274,621 |
| 40.02 | Site Utilities, Utility Relocation | 0.55 | Route-miles | \$ 2,250,000 | \$ 1,235,795 |
| 40 SUBTOTAL | | | | | \$ 1,510,417 |
| 40 ALLOCATED CONTINGENCY | | | | 30% | \$ 453,125 |
| 40 TOTAL | | | | | \$ 2,060,000 |
| 50 SYSTEMS | | | | | |
| Sub Category | Item | Quantity | Unit | Unit Cost | Total Cost |
| 50.01 | Overhead Contact System (See Separate Estimate) | 1 | LS | \$ 1,802,872 | \$ 1,802,872 |
| 50.02 | Switch Machines and Signals | 1 | LS | \$ 705,128 | \$ 705,128 |
| 50.03 | Intersection LRT/Traffic Signal Controller Interfaces | 5 | Each | \$ 250,000 | \$ 1,250,000 |
| 50.04 | Traction Power Substations | 0.55 | Route-miles | \$ 4,000,000 | \$ 2,200,000 |
| 50 SUBTOTAL | | | | | \$ 5,958,000 |
| 50 ALLOCATED CONTINGENCY | | | | 30% | \$ 1,787,400 |
| 50 TOTAL | | | | | \$ 8,130,000 |
| 60 RIGHT OF WAY, LAND, EXISTING IMPROVEMENTS | | | | | |
| Sub Category | Item | Quantity | Unit | Unit Cost | Total Cost |
| 60.01 | | | Acre | \$ 0 | \$ 0 |
| 60 SUBTOTAL | | | | | \$ 0 |
| 60 ALLOCATED CONTINGENCY | | | | 30% | \$ 0 |
| 60 TOTAL | | | | | \$ 0 |
| 70 VEHICLES | | | | | |
| Sub Category | Item | Quantity | Unit | Unit Cost | Total Cost |
| | | | | \$ - | \$ - |

| Table 61 – Research Park Branch Capital Cost Estimate | | | |
|--|--|------------------------|----------------------|
| | | | \$ - |
| 70 SUBTOTAL | | | \$ - |
| 70 ALLOCATED CONTINGENCY | | | 0% |
| 70 TOTAL | | | \$ - |
| 80 PROFESSIONAL SERVICES | | | |
| SCC 10 - 50 TOTAL | | | \$ 14,320,000 |
| Sub Category | Total Cost | %of SCC 10 - 50 | Total Cost |
| 80.01 | Preliminary Engineering | 3% | \$ 429,600 |
| 80.02 | Final Design | 7% | \$ 1,002,400 |
| 80.03 | Project Management for Design and Construction | 5% | \$ 716,000 |
| 80.04 | Construction Administration and Management | 6% | \$ 859,200 |
| 80.05 | Insurance | 3% | \$ 429,600 |
| 80.06 | Legal, Permits, Review Fees | 2% | \$ 286,400 |
| 80.07 | Survey, Testing, Investigation, Inspection | 2% | \$ 286,400 |
| 80.08 | Start-up Costs | 2% | \$ 286,400 |
| 80 TOTAL | | | \$ 1,020,000 |
| Summary | | | |
| Standard Cost Category | | | Total Cost |
| SCC 10: Guideway and Track Elements | | | \$ 4,570,000 |
| SCC 20: Stations, Stops, Terminals, Intermodal | | | \$ 4,130,000 |
| SCC 30: Support Facilities, Yards, Shops, Administration Buildings | | | \$ - |
| SCC 40: Sitework and Special Conditions | | | \$ 2,060,000 |
| SCC 50: Systems | | | \$ 8,130,000 |
| SCC 60: Right of Way, Land, Existing Improvements | | | \$ - |
| SCC 70: Vehicles | | | \$ - |
| SCC 80: Professional Services | | | \$ 4,510,000 |
| SUBTOTAL | | | \$ 23,400,000 |
| UNALLOCATED CONTINGENCY | | | 30% |
| PROJECT TOTAL | | | \$ 30,420,000 |

17 Appendix H – Trunk Line Curve Speed Upgrade Concept Design

The UTA Trunk Line is the original light rail line opened from downtown Salt Lake City to the communities of South Salt Lake, Murray, Midvale, and Sandy. The line opened in 1999 with a southern terminus of Sandy Civic Center. In 2013, the line, which by that time had been designated the Blue Line, was extended from Sandy Civic Center to Draper Town Center, following the alignment of a disused Union Pacific freight line that formerly connected Salt Lake City with Provo.

UTA's design criteria at the time of original light rail design called for a maximum design speed of 55 mph. This was consistent with the maximum operating speed of UTA's original light rail fleet, the Siemens SD100s, as well as with light rail industry standards across North America. As additional light rail segments entered the planning and design stages, especially the Red Line from Fashion Place West to Daybreak Parkway, UTA design criteria for maximum system speed was increased to 65 mph. The more recent light rail vehicle procurement of Siemens S70s brought higher speed capability to the UTA light rail fleet.

The FOLR Study evaluated the feasibility of modifying the original Trunk Line from Ballpark Station, where it enters dedicated right-of-way to the south, to Sandy Civic Center and Draper Town Center, to 65 mph operation where feasible. The intent of this change is to improve the competitiveness of light rail travel times versus other modes while making only small changes to the TRAX infrastructure. These changes may involve adding super-elevation to curves (increasing the height differential of the two rails to support faster speeds), modifying curve spirals or, in some cases, simply recomputing appropriate speeds for existing curve geometry based on the updated UTA design criteria. The intent of these changes is to reduce travel times without shifting track locations, acquiring additional right-of-way, relocating catenary poles or requiring significant station work. The higher speeds may require some signal system changes as the signal design safe braking distance was assumed to be 55 mph at the time the signal system was designed.

Table 62 shows the station-by-station travel time savings, as predicted by five 24-hour simulations of the Future Baseline and FOLR Phase 1 Scenario 2 TrainOps simulations. As such, these results reflect "real world" type operation with train congestion, dwell time variability and the mix of SD100/SD160 and S70 light rail vehicles north of the Blue/Red Line merge location of Fashion Place West. Travel time savings in each direction is about 240 seconds, which is about 4 minutes.

This appendix also includes the concept track design computations for the TRAX Trunk Line curve speed upgrade concept design. The table is color-coded as follows:

- + Green shading – Either already has a design speed of 65 mph or can be upgraded with no impacts beyond superelevation increase
- + Blue shading – Can be upgraded to 65 mph, but infrastructure impacts such as minor platform modifications or grade crossing reprofiling will need to be assessed
- + Yellow shading – Cannot be upgraded to 65 mph but some curve speed improvements are possible. The values in this appendix show the maximum design speed based on UTA design standards including actual superelevation (Ea) not to exceed 4 inches

All three categories of curve speed improvements were assumed in the Strategic Plan, though only up to the operating speed that is consistent with UTA design criteria. Note that Curves 123/125/132/134 do require a slight design exception for minimum tangent length. This design exception is likely to be granted and, therefore, the improved speeds at these four locations was assumed in the operations simulations and travel demand modeling for the Strategic Plan.

| Table 62 – Simulated Travel Time Benefits – Trunk Line Curve Speed Improvements | | | | | | |
|---|-----------------|-------------------|-----------------|-------------------|-------------------|------------|
| Station Pair | Northbound | | Southbound | | Savings (Seconds) | |
| | Future Baseline | With Improvements | Future Baseline | With Improvements | Northbound | Southbound |
| Draper Town Center – Kimballs Lane | 134 | 134 | 135 | 119 | 0 | 16 |
| Kimballs Lane – Crescent View | 92 | 78 | 98 | 75 | 14 | 23 |
| Crescent View – Sandy Civic Center | 170 | 151 | 169 | 150 | 19 | 19 |
| Sandy Civic Center – Sandy Expo | 97 | 84 | 98 | 85 | 13 | 13 |
| Sandy Expo – Historic Sandy | 88 | 70 | 82 | 69 | 18 | 13 |
| Historic Sandy – Midvale Center | 154 | 138 | 157 | 139 | 16 | 18 |
| Midvale Center – Midvale Fort Union | 106 | 79 | 98 | 80 | 27 | 18 |
| Midvale Fort Union – Fashion Place West | 135 | 104 | 116 | 99 | 31 | 17 |
| Fashion Place West – Murray Central | 187 | 176 | 179 | 182 | 11 | (03) |
| Murray Central – Murray North | 139 | 115 | 140 | 116 | 24 | 24 |
| Murray North - Meadowbrook | 111 | 89 | 101 | 87 | 22 | 14 |
| Meadowbrook - Millcreek | 117 | 96 | 109 | 96 | 21 | 13 |
| Millcreek – Central Pointe | 176 | 160 | 212 | 171 | 16 | 41 |
| Central Pointe - Ballpark | 134 | 123 | 153 | 130 | 11 | 23 |
| Total | 1839 | 1596 | 1847 | 1598 | 243 | 249 |

| Table 63 – Trunk Line Curve Speed Upgrade Concept Design | | | | | | |
|--|--------------|----------------------|------------|-----------------------|-------------|---------------------------------|
| | Curve Number | Current Design Speed | Current Ea | Proposed Design Speed | Proposed Ea | Notes |
| Draper Extension | S110 | 65 | 3.75 | 65.00 | 3.75 | |
| | N110 | 65 | 3.75 | 65.00 | 3.75 | |
| | S112 | 40 | 0.00 | 65.00 | 1.25 | |
| | N112 | 40 | 0.00 | 65.00 | 2.75 | |
| | S120 | 30 | 1.00 | 50.00 | 4.00 | Compound Curve, Crossovers |
| | S122 | 30 | 0.00 | 60.00 | 4.00 | Draper Parkway Grade Crossing |
| | N120 | 30 | 1.00 | 50.00 | 4.00 | Compound Curve, Crossovers |
| | N122 | 30 | 0.00 | 60.00 | 4.00 | Draper Parkway Grade Crossing |
| | S130 | 65 | 0.00 | 65.00 | 0.00 | |
| | N125 | 65 | 0.00 | 65.00 | 0.00 | |
| | S135 | 65 | 0.00 | 65.00 | 0.00 | |
| | N128 | 65 | 0.00 | 65.00 | 0.00 | |
| | S140 | 65 | 0.00 | 65.00 | 0.00 | |
| | S150 | 65 | 0.00 | 65.00 | 0.00 | |
| | S160 | 65 | 0.00 | 65.00 | 0.00 | |
| | S170 | 55 | 1.50 | 65.00 | 2.25 | 11400 south Grade Crossing |
| | N130 | 60 | 1.75 | 65.00 | 2.25 | 11400 south Grade Crossing |
| | S180 | 55 | 3.00 | 65.00 | 4.00 | Runoff next to 11400 S Platform |
| | N140 | 55 | 3.00 | 65.00 | 4.00 | Runoff next to 11400 S Platform |
| | S190 | 65 | 2.75 | 65.00 | 3.25 | |
| N150 | 65 | 2.75 | 65.00 | 2.75 | | |
| S200 | 65 | 0.00 | 65.00 | 0.00 | | |
| N160 | 65 | 0.00 | 65.00 | 0.00 | | |

| Table 63 – Trunk Line Curve Speed Upgrade Concept Design | | | | | | |
|--|--------------|----------------------|------------|-----------------------|--|---|
| | Curve Number | Current Design Speed | Current Ea | Proposed Design Speed | Proposed Ea | Notes |
| | S210 | 65 | 0.00 | 65.00 | 0.00 | |
| | N170 | 65 | 0.00 | 65.00 | 0.00 | |
| | S220 | 55 | 1.00 | 65.00 | 1.75 | |
| | N180 | 55 | 1.50 | 65.00 | 2.25 | |
| North/South | 100 | 55 | 0.00 | 65.00 | 0.00 | |
| | 102 | 55 | 0.00 | 65.00 | 0.00 | |
| | 105 | 35 | 0.00 | 65.00 | 1.50 | Runoff next to 10000 South Platform |
| | 104 | 55 | 1.25 | 65.00 | 1.50 | |
| | 107 | 55 | 1.25 | 65.00 | 1.50 | |
| | 106 | 55 | 1.25 | 65.00 | 0.00 | |
| | 108 | 55 | 0.62 | 65.00 | 0.00 | |
| | 110 | 55 | 0.00 | 65.00 | 0.00 | |
| | 109 | 55 | 1.00 | 65.00 | 1.25 | |
| | 112 | 55 | 0.00 | 65.00 | 0.00 | |
| | 114 | 55 | 1.00 | 65.00 | 1.25 | Short Tangent |
| | 111 | 55 | 1.00 | 65.00 | 2.00 | |
| | 120 | 55 | 1.00 | 65.00 | 2.00 | |
| | 113 | 50 | 1.50 | 65.00 | 3.00 | Runoff next to Midvale Center (7800 South) Platform |
| | 115 | 55 | 1.25 | 65.00 | 1.50 | |
| | 120 | 55 | 1.00 | 65.00 | 2.00 | |
| | 122 | 55 | 0.00 | 65.00 | 0.00 | |
| | 124 | 55 | 1.25 | 65.00 | 1.50 | |
| | 117 | 55 | 1.75 | 65.00 | 3.00 | |
| | 119 | 40 | 1.50 | 60.00 | 4.00 | |
| | 121 | 30 | 0.00 | 60.00 | 4.00 | |
| | 126 | 55 | 1.75 | 65.00 | 3.00 | |
| | 128 | 40 | 1.50 | 60.00 | 4.00 | |
| | 130 | 40 | 0.00 | 65.00 | 2.75 | Runoff next to Midvale Fort Union (7200 South) Platform / 7200 South Grade Crossing |
| | 123 | 55 | 1.25 | 65.00 | 1.75 | Design Exception for Tangent Length |
| | 125 | 55 | 1.25 | 65.00 | 1.75 | Design Exception for Tangent Length |
| | 132 | 55 | 1.25 | 65.00 | 1.75 | Design Exception for Tangent Length |
| | 134 | 55 | 1.25 | 65.00 | 1.75 | Design Exception for Tangent Length |
| | 136 | 55 | 0.00 | 65.00 | 0.00 | |
| | 138 | 55 | 0.00 | 65.00 | 0.00 | |
| | 140 | 15 | 0.00 | 35.00 | 4.00 | |
| | 142 | 55 | 1.25 | 65.00 | 1.75 | |
| 127 | 50 | 3.25 | 55.00 | 4.00 | | |
| 144 | 50 | 3.25 | 55.00 | 4.00 | | |
| 129 | 50 | 2.50 | 60.00 | 4.00 | | |
| 133 | 50 | 0.50 | 65.00 | 2.25 | Runoff next to Murray Central (5300 South) Platform / Vine Street Grade Crossing | |

Table 63 – Trunk Line Curve Speed Upgrade Concept Design

| Curve Number | Current Design Speed | Current Ea | Proposed Design Speed | Proposed Ea | Notes |
|--------------|----------------------|------------|-----------------------|-------------|--|
| 146 | 40 | 1.50 | 60.00 | 4.00 | |
| 148 | 50 | 0.50 | 65.00 | 2.25 | Runoff next to Murray Central (5300 South) Platform / Vine Street Grade Crossing |
| 150 | 50 | 0.50 | 65.00 | 2.25 | |
| 135 | 55 | 1.75 | 65.00 | 2.75 | |
| 150 | 50 | 1.50 | 65.00 | 2.25 | |
| 152 | 55 | 1.75 | 65.00 | 2.75 | |
| 137 | 55 | 0.00 | 65.00 | 0.00 | |
| 139 | 55 | 0.00 | 65.00 | 0.00 | |
| 141 | 50 | 1.75 | 65.00 | 3.50 | |
| 154 | 55 | 0.00 | 65.00 | 0.00 | |
| 156 | 55 | 0.00 | 65.00 | 0.00 | |
| 158 | 50 | 1.25 | 65.00 | 2.25 | |
| 160 | 50 | 1.25 | 65.00 | 2.25 | Runoff next to Murray North (4500 South) Platform / 4366 South Grade Crossing |
| 162 | 50 | 1.75 | 65.00 | 3.50 | Runoff next to Murray North (4500 South) Platform / 4366 South Grade Crossing |
| 143 | 55 | 1.50 | 65.00 | 2.25 | |
| 164 | 55 | 1.50 | 65.00 | 2.25 | |
| 147 | 55 | 0.00 | 65.00 | 0.00 | |
| 154 | 55 | 0.00 | 65.00 | 0.00 | |
| 166 | 55 | 0.00 | 65.00 | 0.00 | |
| 149 | 45 | 3.50 | 45.00 | 4.00 | |
| 168 | 45 | 3.50 | 45.00 | 4.00 | |
| 151 | 55 | 0.00 | 65.00 | 0.00 | |
| 153 | 55 | 0.00 | 65.00 | 0.00 | |
| 155 | 55 | 0.00 | 65.00 | 0.00 | |
| 157 | 55 | 0.00 | 65.00 | 0.00 | |
| 175 | 45 | 0.00 | 65.00 | 1.00 | |
| 176 | 55 | 0.00 | 65.00 | 0.00 | |
| 167 | 55 | 0.00 | 65.00 | 0.00 | |
| 169 | 55 | 0.00 | 65.00 | 0.00 | |
| 170 | 55 | 0.00 | 65.00 | 0.00 | |
| 171 | 55 | 0.00 | 65.00 | 0.00 | |
| 172 | 55 | 0.00 | 65.00 | 0.00 | |
| 173 | 55 | 0.00 | 65.00 | 0.00 | |
| 174 | 55 | 0.00 | 65.00 | 0.00 | |
| 179 | 55 | 0.00 | 65.00 | 0.00 | |
| 177 | 45 | 0.00 | 65.00 | 1.00 | |
| 178 | 55 | 0.00 | 65.00 | 0.00 | |
| 179 | 55 | 0.00 | 65.00 | 0.00 | |
| 181 | 55 | 0.00 | 65.00 | 0.00 | |
| 180 | 55 | 0.00 | 65.00 | 0.00 | |
| 182 | 55 | 0.00 | 65.00 | 0.00 | |
| 183 | 55 | 0.00 | 65.00 | 0.00 | |
| 186 | 55 | 0.00 | 65.00 | 0.00 | |

| Table 63 – Trunk Line Curve Speed Upgrade Concept Design | | | | | | |
|--|--------------|----------------------|------------|-----------------------|-------------|-------|
| | Curve Number | Current Design Speed | Current Ea | Proposed Design Speed | Proposed Ea | Notes |
| | 188 | 55 | 0.00 | 65.00 | 0.00 | |
| | 190 | 25 | 0.00 | 55.00 | 4.00 | |
| | 184 | 55 | 0.00 | 65.00 | 0.00 | |
| | 185 | 55 | 0.00 | 65.00 | 0.00 | |
| | 187 | 25 | 0.00 | 65.00 | 0.00 | |
| | 189 | 25 | 0.00 | 65.00 | 0.00 | |
| | 192 | 25 | 0.00 | 55.00 | 4.00 | |

The \$21.4 million total estimated cost (in 2022 dollars) of the project is shown in Table 64. The cost is dominated by the trackwork changes with lesser costs for station platform adjustments, roadway modifications, signals and Overhead Contact System (OCS). The total estimated cost of the project includes 30% allocated contingency for each of the standard FTA cost categories as well as 30% unallocated contingency. The estimate also includes professional services and other “soft” costs using standard cost factors.

| Table 64 – Trunk Line Curve Speed Upgrade Capital Cost Estimate | | | | | | |
|---|---|----------|-------------|--------------|----------------------|--|
| 10 GUIDEWAY AND TRACK ELEMENTS | | | | | | |
| Sub Category | Item | Quantity | Unit | Unit Cost | Total Cost | |
| 10.11 | Track: Ballasted | 2.05 | Route-miles | \$ 2,650,000 | \$ 5,432,500 | |
| 10.13 | Track: Resurfacing for Increased Superelevation | 3.27 | Route-miles | \$ 1,100,000 | \$ 3,597,000 | |
| 10.14 | Track: Grade Crossing Replacement | 3 | Each | \$ 75,000 | \$ 225,000 | |
| 10 SUBTOTAL | | | | | \$ 9,254,500 | |
| 10 ALLOCATED CONTINGENCY | | | | 30% | \$ 2,776,350 | |
| 10 TOTAL | | | | | \$ 12,030,000 | |
| 20 STATIONS, SHOPS, TERMINALS, INTERMODAL | | | | | | |
| Sub Category | Item | Quantity | Unit | Unit Cost | Total Cost | |
| 20.01 | At-grade Station, Modify Platform Edge | 1000 | Route-feet | \$ 200 | \$ 200,000 | |
| 20 SUBTOTAL | | | | | \$ 200,000 | |
| 20 ALLOCATED CONTINGENCY | | | | 30% | \$ 60,000 | |
| 20 TOTAL | | | | | \$ 260,000 | |
| 40 SITEWORK AND SPECIAL CONDITIONS | | | | | | |
| Sub Category | Item | Quantity | Unit | Unit Cost | Total Cost | |
| 40.01 | Demolition, Clearing, Earthwork | 2.05 | Route-Miles | \$ 500,000 | \$ 1,025,000 | |
| 40.08 | Roadway - Mill and Pave for Grade Crossing Reconstruction | 3 | Each | \$ 100,000 | \$ 300,000 | |
| 40 SUBTOTAL | | | | | \$ 1,025,000 | |
| 40 ALLOCATED CONTINGENCY | | | | 30% | \$ 307,500 | |
| 40 TOTAL | | | | | \$ 1,330,000 | |
| 50 SYSTEMS | | | | | | |
| Sub Category | Item | Quantity | Unit | Unit Cost | Total Cost | |
| 50.01 | Catenary Modifications | 1 | LS | \$ 680,000 | \$ 680,000 | |
| 50.02 | Automatic Signal Relocations | 8 | Each | \$ 90,000 | \$ 720,000 | |
| 50 SUBTOTAL | | | | | \$ 1,400,000 | |

Table 64 – Trunk Line Curve Speed Upgrade Capital Cost Estimate

| 50 ALLOCATED CONTINGENCY | | 30% | \$ | 420,000 | |
|--|--|----------|-----------------|----------------------|------------------|
| 50 TOTAL | | | \$ | 1,820,000 | |
| 60 RIGHT OF WAY, LAND, EXISTING IMPROVEMENTS | | | | | |
| Sub Category | Item | Quantity | Unit | Unit Cost | Total Cost |
| 60.01 | | | Acre | \$ 0 | \$ 0 |
| 60 SUBTOTAL | | | | | \$ 0 |
| 60 ALLOCATED CONTINGENCY | | 30% | | | \$ 0 |
| 60 TOTAL | | | | | \$ 0 |
| 70 VEHICLES | | | | | |
| Sub Category | Item | Quantity | Unit | Unit Cost | Total Cost |
| | | | | \$ - | \$ - |
| | | | | \$ - | \$ - |
| 70 SUBTOTAL | | | | | \$ - |
| 70 ALLOCATED CONTINGENCY | | 0% | | | \$ - |
| 70 TOTAL | | | | | \$ - |
| 80 PROFESSIONAL SERVICES | | | | | |
| SCC 10 - 50 TOTAL | | | | \$ | 5,200,000 |
| Sub Category | Total Cost | | %of SCC 10 - 50 | Total Cost | |
| 80.01 | Preliminary Engineering | | 3% | \$ 102,300 | |
| 80.02 | Final Design | | 7% | \$ 238,700 | |
| 80.03 | Project Management for Design and Construction | | 5% | \$ 170,500 | |
| 80.04 | Construction Administration and Management | | 6% | \$ 204,600 | |
| 80.05 | Insurance | | 3% | \$ 102,300 | |
| 80.06 | Legal, Permits, Review Fees | | 2% | \$ 68,200 | |
| 80.07 | Survey, Testing, Investigation, Inspection | | 2% | \$ 68,200 | |
| 80.08 | Start-up Costs | | 2% | \$ 68,200 | |
| 80 TOTAL | | | | \$ 1,020,000 | |
| Summary | | | | | |
| Standard Cost Category | | | | Total Cost | |
| SCC 10: Guideway and Track Elements | | | | \$ 12,030,000 | |
| SCC 20: Stations, Stops, Terminals, Intermodal | | | | \$ 260,000 | |
| SCC 30: Support Facilities, Yards, Shops, Administration Buildings | | | | \$ - | |
| SCC 40: Sitework and Special Conditions | | | | \$ 1,330,000 | |
| SCC 50: Systems | | | | \$ 1,820,000 | |
| SCC 60: Right of Way, Land, Existing Improvements | | | | \$ - | |
| SCC 70: Vehicles | | | | \$ - | |
| SCC 80: Professional Services | | | | \$ 1,020,000 | |
| SUBTOTAL | | | | \$ 16,460,000 | |
| UNALLOCATED CONTINGENCY | | | 30% | \$ 4,938,000 | |
| PROJECT TOTAL | | | | \$ 21,400,000 | |

18 Appendix I – Union Turnback Track and Green Line West to South Connection Concept Design

Currently, all TRAX trains needing to go south from, or north to, the Jordan River Service Center on the main North/South line have to pull into Central Pointe Station for the operator to change ends. This process takes approximately four minutes and, with a train passing through the station every 2 to 3 minutes on average, can cause system delays. The proposed project would allow for such trains to avoid this special maneuver by constructing a track connection in the southwest quadrant of the junction between the North/South Line and the Green Line.

The project would also construct a four-car siding or turnback track on the west side of the North/South Line. This track would serve three operational purposes:

- + Support holding a non-revenue train destined for the Green Line or destined for the North/South Line until a delay-free operating slot is available without delaying following revenue trains on the line being exited
- + Allow the staging of a special events train for Ballpark Station or other downtown stations without blocking the North/South Line
- + Temporarily holding a train that was unexpectedly removed from service due to a vehicle issue until it can be operated (or towed) to Midvale or Jordan River

The UTA Light Rail Business Unit desires this project and it is currently included on the future State of Good Repair list. However, the project is not presently scheduled or funded. The project would not directly improve travel time or capacity; however, it would improve system reliability, as measured by OTP, as well as operational flexibility. The project would improve operational efficiency by eliminating the time-consuming reversing move at Central Pointe Station for both morning train put-ins and evening train lay-ups. It would also eliminate the reversing move for non-revenue train movements that commonly occur as vehicles are shuttled between Jordan River and Midvale Service Centers.

The concept design was refined during FOLR Phase 1 and is shown in Figure 40. The existing R.C. Willey Appliance Warehouse freight siding would need to be relocated to the south in order to provide sufficient room for the siding/turnback track. The siding/turnback track is connected to the mainline with No. 6 turnouts, suitable for light rail operations but not usable by freight trains (such as freight locomotive running around its train to change direction). The turnout at the south end of the siding/turnback track is located south of the grade crossing while a maximum length (four-car) train would fit north of the crossing. The southbound interlocked home signal would be located immediately north of the grade crossing and would be interfaced with the crossing warning systems such that the flashers would activate and gates would descend as soon as the TRAX dispatcher cleared a southbound route from the siding/turnback track. For northbound trains accessing the siding/turnback track from the south, the existing Yellowstone Interlocking crossovers on the North/South Line would be used so that the northbound train would operate a short section on the normally-southbound track before diverging to the new track.

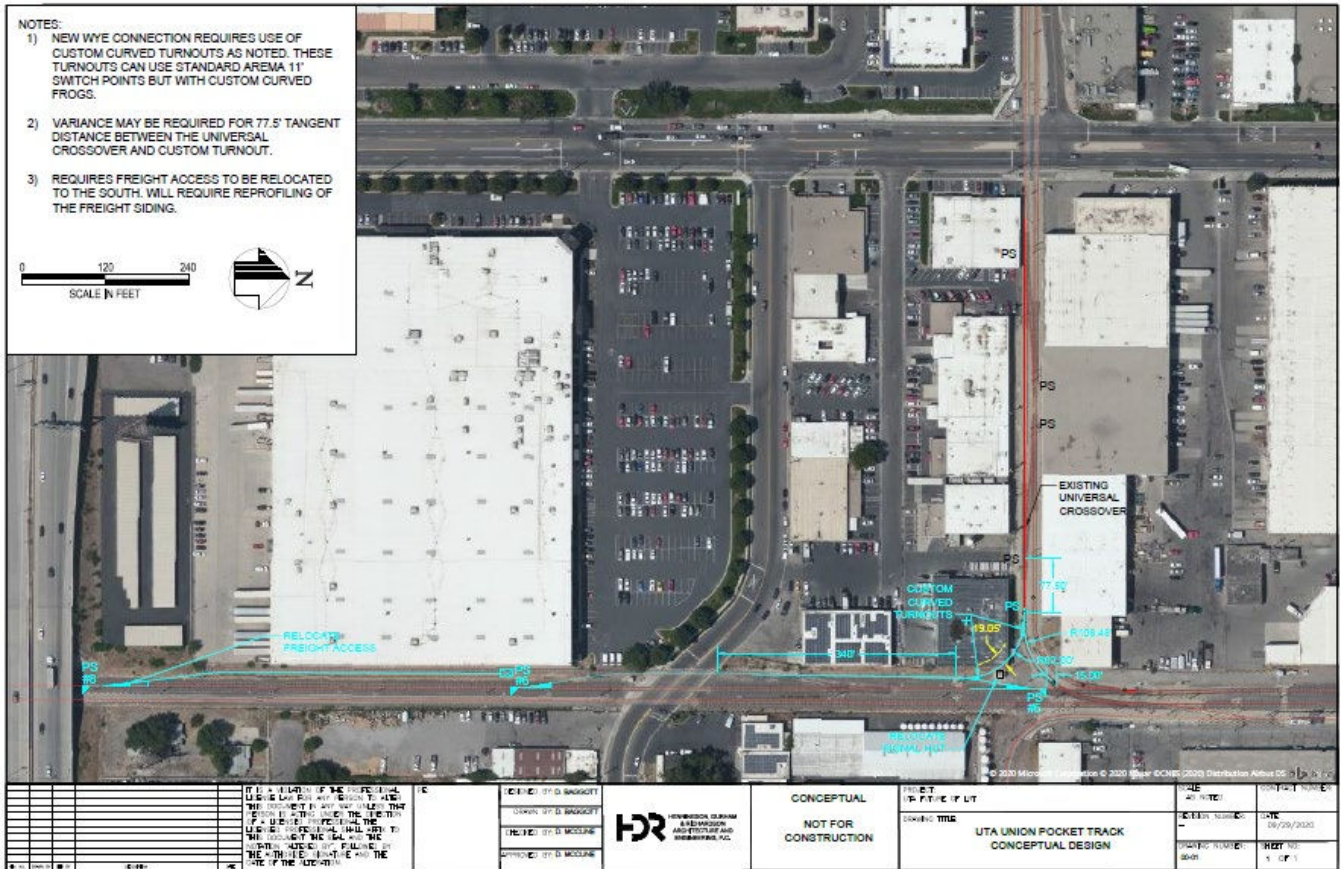

Figure 40 – Union Turnback Track and Green Line West to South Connection Concept Model

The use of custom curved turnouts for the Green Line connection is necessary in order to retain the existing Green Line universal crossover located immediately west of the proposed project. Such custom turnouts are not industry-standard items and would require additional spare parts inventory at UTA.

The \$13.1 million total estimated cost (in 2022 dollars) of the project is shown in Table 65. The major cost components are trackwork, signals and Overhead Contact System (OCS). The estimate includes \$0.4 million (prior to allocation of contingencies) for property taking and partial demolition of the building in the southwest quadrant of the connection. The cost of reconstructing the R. C. Willey freight siding is included but no financial compensation to the property owner for this change is assumed. The conceptual extent of the taking is shown in the concept drawing. The total estimated cost of the project includes 30% allocated contingency for each of the standard FTA cost categories as well as 30% unallocated contingency. The estimate also includes professional services and other “soft” costs using standard cost factors.

Table 65 – Union Turnback Track and Green Line West to South Connection Capital Cost Estimate

| 10 GUIDEWAY AND TRACK ELEMENTS | | | | | |
|---|--|-----------------|-------------|------------------|---------------------|
| Sub Category | Item | Quantity | Unit | Unit Cost | Total Cost |
| 10.01 | Guideway: At-grade Exclusive ROW | 0.15 | Route-miles | \$ 680,000 | \$ 107,100 |
| 10.11 | Track: Ballasted | 1600 | Track-feet | \$ 600 | \$ 1,008,000 |
| 10.12 | Track: Special - New #6 Turnout | 2 | Each | \$ 100,000 | \$ 210,000 |
| 10.12 | Track: Special - New #8 Turnout | 1 | Each | \$ 150,000 | \$ 157,500 |
| 10.12 | Track: Special - Custom Curved Turnout | 3 | Each | \$ 125,000 | \$ 393,750 |
| | Reprofiling of Freight Access Track | 800 | Each | \$ 300 | \$ 252,000 |
| 10 SUBTOTAL | | | | | \$ 2,027,000 |
| 10 ALLOCATED CONTINGENCY | | | | 30% | \$ 608,100 |
| 10 TOTAL | | | | | \$ 2,635,100 |
| 20 STATIONS, SHOPS, TERMINALS, INTERMODAL | | | | | |
| Sub Category | Item | Quantity | Unit | Unit Cost | Total Cost |
| | | | | \$ - | \$ - |
| 20 SUBTOTAL | | | | | \$ - |
| 20 ALLOCATED CONTINGENCY | | | | 30% | \$ - |
| 20 TOTAL | | | | | \$ - |
| 40 SITEWORK AND SPECIAL CONDITIONS | | | | | |
| Sub Category | Item | Quantity | Unit | Unit Cost | Total Cost |
| 40.01 | Demolition, Clearing, Earthwork | 0.15 | Route-Miles | \$ 500,000 | \$ 78,750 |
| 40.02 | Site Utilities, Utility Relocation | 0.15 | Route-miles | \$ 2,250,000 | \$ 354,375 |
| 40 SUBTOTAL | | | | | \$ 412,500 |
| 40 ALLOCATED CONTINGENCY | | | | 30% | \$ 123,750 |
| 40 TOTAL | | | | | \$ 536,250 |
| 50 SYSTEMS | | | | | |
| Sub Category | Item | Quantity | Unit | Unit Cost | Total Cost |
| 50.01 | Overhead Contact System | 1 | LS | \$ 705,626 | \$ 740,908 |
| 50.02 | Signals | 1 | LS | \$ 2,691,288 | \$ 2,825,852 |
| | | | | \$ - | \$ - |
| 50 SUBTOTAL | | | | | \$ 3,396,914 |
| 50 ALLOCATED CONTINGENCY | | | | 30% | \$ 1,019,074 |
| 50 TOTAL | | | | | \$ 4,415,988 |
| 60 RIGHT OF WAY, LAND, EXISTING IMPROVEMENTS | | | | | |
| Sub Category | Item | Quantity | Unit | Unit Cost | Total Cost |
| 60.01 | Purchase of Part of property at new pocket track curve | 0.10 | Acre | \$ 1,524,600 | \$ 160,083 |
| 60.02 | Partial demolition of building | 1 | LS | \$ 250,000 | \$ 262,500 |
| 60 SUBTOTAL | | | | | \$ 402,460 |
| 60 ALLOCATED CONTINGENCY | | | | 30% | \$ 120,738 |
| 60 TOTAL | | | | | \$ 523,198 |
| 70 VEHICLES | | | | | |
| Sub Category | Item | Quantity | Unit | Unit Cost | Total Cost |
| | | | | \$ - | \$ - |
| | | | | \$ - | \$ - |
| 70 SUBTOTAL | | | | | \$ - |
| 70 ALLOCATED CONTINGENCY | | | | 0% | \$ - |
| 70 TOTAL | | | | | \$ - |

Table 65 – Union Turnback Track and Green Line West to South Connection Capital Cost Estimate

| 80 PROFESSIONAL SERVICES | | | |
|--|--|------------------------|----------------------|
| SCC 10 - 50 TOTAL | | | \$ 5,200,000 |
| Sub Category | Total Cost | %of SCC 10 - 50 | Total Cost |
| 80.01 | Preliminary Engineering | 3% | \$ 156,000 |
| 80.02 | Final Design | 7% | \$ 364,000 |
| 80.03 | Project Management for Design and Construction | 5% | \$ 260,000 |
| 80.04 | Construction Administration and Management | 6% | \$ 312,000 |
| 80.05 | Insurance | 3% | \$ 156,000 |
| 80.06 | Legal, Permits, Review Fees | 2% | \$ 104,000 |
| 80.07 | Survey, Testing, Investigation, Inspection | 2% | \$ 104,000 |
| 80.08 | Start-up Costs | 2% | \$ 104,000 |
| 80 TOTAL | | | \$ 1,560,000 |
| Summary | | | |
| Standard Cost Category | | | Total Cost |
| SCC 10: Guideway and Track Elements | | | \$ 2,770,000 |
| SCC 20: Stations, Stops, Terminals, Intermodal | | | \$ - |
| SCC 30: Support Facilities, Yards, Shops, Administration Buildings | | | \$ - |
| SCC 40: Sitework and Special Conditions | | | \$ 560,000 |
| SCC 50: Systems | | | \$ 4,640,000 |
| SCC 60: Right of Way, Land, Existing Improvements | | | \$ 550,000 |
| SCC 70: Vehicles | | | \$ - |
| SCC 80: Professional Services | | | \$ 1,560,000 |
| SUBTOTAL | | | \$ 10,080,000 |
| UNALLOCATED CONTINGENCY | | 30% | \$ 3,024,000 |
| PROJECT TOTAL | | | \$ 13,100,000 |

19 Appendix J – Future of Light Rail Study Technical Advisory Committee

Table 66 lists the stakeholders representing municipal and state partners, as well as Metropolitan Planning Organizations, who participated in the Future of Light Rail Technical Advisory Committee.

| Table 66 – Future of Light Rail Study Technical Advisory Committee | |
|---|-----------------------|
| Organization | Department |
| Draper | Community Development |
| Draper | Engineering |
| Lehi | Community Development |
| Lehi | Planning |
| Midvale | Planning |
| Millcreek City | Community Development |
| Millcreek City | Leadership |
| Millcreek City | Planning |
| Mountainland Association of Governments (2) | Planning |
| Murray | Engineering |
| Murray | Planning |
| Salt Lake City (4) | Planning |
| Salt Lake County | Planning |
| Salt Lake County | Transportation |
| Sandy | Community Development |
| Sandy | Engineering |
| South Salt Lake City | Engineering |
| UDOT (2) | Planning |
| UDOT (2) | Engineering |
| University of Utah (2) | Planning |
| Wasatch Front Regional Council (4) | Planning |
| Wasatch Front Regional Council | Community Development |
| West Jordan City | Engineering |
| West Jordan City (2) | Planning |
| West Valley City | Engineering |
| West Valley City | Community Development |
| South Jordan | Engineering |
| South Jordan | Planning |

In addition to the external stakeholder representation shown in Table 66, the following UTA departments and groups participated as part of the Technical Advisory Committee:

- + UTA Capital Assets & Project Controls
- + UTA Community Engagement
- + UTA Engineering
- + UTA Environmental & Grant Services
- + UTA Finance – Business & Quality
- + UTA Finance - Budget & Financial

- + UTA Light Rail Operations Planning
- + UTA Light Rail Operations
- + UTA Light Rail Vehicle Maintenance
- + UTA Light Rail Vehicle Maintenance – Fleet Engineering
- + UTA Planning Leadership
- + UTA Planning – Strategic Planning
- + UTA Planning – Service Planning
- + UTA Planning – Customer Experience
- + UTA Public Relations and Marketing
- + UTA Safety
- + UTA Service Development Leadership
- + UTA Real Estate – Transit Oriented Development
- + UTA Real Estate - Right of Way Assets
- + UTA Real Estate Leadership
- + UTA Operations
- + UTA Operations Leadership